

Frymaster®

Canada Price List



Effective: January 01, 2024



@thegarlandcanada



@garlandcanada_



@welbiltcanada



garlandcanada.ca



Visit Welbilt Brand Portal:

<https://assets.welbilt.com/login/>

GARLAND®
CANADA

Price List Canada

NOTICE:

FRYMASTER/ DEAN PRODUCTS ARE NOT APPROVED OR AUTHORIZED FOR HOME OR RESIDENTIAL USE, BUT ARE INTENDED FOR COMMERCIAL APPLICATIONS ONLY. FRYMASTER/ DEAN WILL NOT PROVIDE SERVICE, WARRANTY, MAINTENANCE OR SUPPORT OF ANY KIND OTHER THAN IN COMMERCIAL APPLICATIONS.

INSTRUCTIONS AND ASSISTANCE IN ORDERING

Specify the following information when ordering:

1. Your purchase order number
2. A specific deliver date/pick-up date
3. Specific shipping instructions, including the complete street address
4. Quantity and model number of unit(s) required
5. Pricing, including all discounts
6. Voltage, cycle (hz), and phase
7. Gas type, specific gravity and pressure (elevation requirements)
8. A drawing or layout sketch of all equipment line-ups of 2 or more units, including all gas hookups and cap position(s)
9. A copy of original quote, if applicable

SERVICE

When corresponding with the factory regarding service, performance or replacement parts, be sure to refer to the particular product by correct model number including prefix and suffix letters, numbers and serial number. This information can be found on the rating plate. Any information pertaining to performance parts or servicing can be obtained by writing our Mississauga office. Continuous product improvement is a Garland policy, therefore specifications and design are subject to change without notice.

TERMS AND CONDITIONS

All prices exclude the Goods and Services Tax (G.S.T.) and Provincial and Local Taxes. All prices are in Canadian Dollars.

Refer to Garland dealer policy for:

- A. Terms of Sale
- B. Equipment Returns or Order Cancellations
- C. Damaged Shipments

Garland Canada reserves the right to change warranties, accessories or product configurations without notice. Access our website at www.GarlandCanada.ca for current information which supercedes any printed information. Further inquiries may also be directed to Customer Service at 1-888-442-7526.

GARLAND CANADA CUSTOMER SERVICE	VOICE	FAX
Sales	(888) 442-7526	(800) 361-2724
KitchenCare (Parts, Service and Warranty)	(844) 724-2273	N/A

CONTENTS

Ordering Information	2
How to Select a Fryer	6-8
FilterQuick® Gas Fryers	9
FilterQuick Fryer Facts	9
FilterQuick 30 Series II Gas Fryers	10
FilterQuick 60 Series II Gas Fryers	11
1814 Gas High-Production Fryers	12
1814 Fryer Facts	12
1814.....	13
OCF30 Oil-Conserving Gas Fryers	14
OCF30 Oil-Conserving Gas Fryer Facts	14
OCF30ATOG and Single OCF30G.....	15
ESG35T Gas Fryer	16
ESG35T Gas Fryer Facts	16
ESG35T Gas Fryer.....	17
LHD65 Low Flue Temperature Gas Fryers	18
LHD65 Fryer Facts.....	18
LHD65	19
High Efficiency HD Gas Fryers	20
HD Fryer Facts.....	20
HD50G	21, 22
HD60G	21, 22
High-Efficiency H55 Gas Fryers	23
H55 F Fryer acts.....	23
H55 7-Year Warranty.....	24
H55	25, 26
Performance MJ Gas Fryers	27
MJ Fryer Facts	27
MJ40.....	28
MJ50.....	29
MJCF.....	30
Standard GF Gas Fryers	31
GF Fryer Facts.....	31
GF14	32
GF40	32

FilterQuick® Electric Fryers	33
FilterQuick Electric Fryer Facts	33
FilterQuick 30 Series II Fryers	34
FilterQuick 60 Series II Fryers	35
1814 High-Production Electric Fryers	36
1814 Fryer Facts	36
1814.....	37
OCF30 Oil-Conserving Electric Fryers	38
OCF30 Fryer Facts.....	38
OCF30ATOE and Single OCF30.....	39, 40
High Efficiency RE Electric Fryers	41
RE Fryer Facts	41
RETC	42, 43
RE	44-46
HPRE.....	47, 48
Dean Decathlon (D) Gas Fryers	49
D60G	49, 50
Dean PowerRunner™ (PR) Gas Fryers	51
PowerRunner Fryer Facts	51
PRG50	52, 53
FPRG50.....	53, 53
Dean Super Runner (SR) Value Gas Fryers	54
Super Runner Fryer Facts.....	54
SR42G	55
SR52G	55
SR62G	55
Dean Super Runner (SRE) Value Electric Fryer	56
SR14E	56
Frymaster & Dean Food Warmers/Holding Pans/Spreaders	57
Frymaster & Dean Portable Filters	58
Frymaster & Dean Shortening Disposal Units	58

CONTENTS *(continued)*

Filter Accessories/Supplies	59
Filter Accessories	59
Filter Paper Chart.....	59
Gas Fryer Accessories.....	60-63
Electric Fryer Accessories	64, 65
Frymaster/Dean Product Summary	66, 67
Fryer Model Guide.....	68
Common Model Numbers and Descriptions.....	68
Frymaster & Dean Factory Warranty	69, 70
Frymaster & Dean Limited Warranty.....	71, 72
Canadian Regional Sales Representatives.....	73

HOW TO SELECT THE FRYER THAT IS BEST FOR YOUR OPERATION

WHAT TYPE OF FRYER SHOULD I USE?

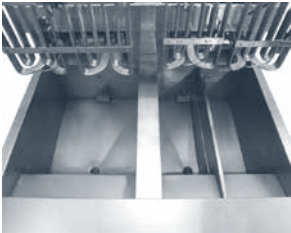
EQUIPMENT	DESCRIPTION	SEDIMENT ZONE	ADVANTAGES	DISADVANTAGES	GREAT FOR FRYING
OPEN POT					
	The term "open pot" refers to the unobstructed heated area of the frypot. Gas fryers heat the frypot from the outside of the pot. Electric fryers have a heating element in the interior of the frypot that is immersed in the oil. Frypots are made of stainless steel.	Open pot frypots are easy to clean but have a smaller sediment area than tube gas fryers. The open pot design allows the operator to visually monitor the amount of sediment in the bottom of the frypot.	Can be used for a broad range of low-to-medium sediment frying needs; easiest to clean. Frymaster's electric fryers have elements that swing and will stay in an up position for easier cleaning.	Smaller sediment zone than most tube fryers; not suited for heavily breaded food products; and not ideal for specialty products.	Best applications are lightly breaded (lower sediment) and freezer-to -fryer breaded product (french fries, hot wings, cheese sticks, and poppers).





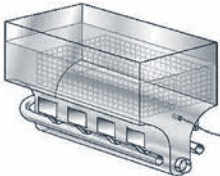
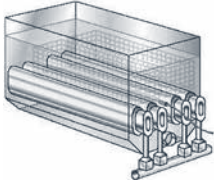
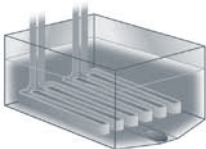



TUBE					
	Tube fryers are gas fryers that have "tubes" in the bottom area of the frypot that are permanently attached to the frypot where the tubes transfer heat to the oil in the frypot. Frypots are made of stainless steel.	Large sediment zone which is ideal for high sediment food product frying.	Can be used for a broad range of frying needs which include low sediment and higher sediment products. Easily adaptable for frying a wide range of food products and large loads.	Harder to clean than an open frypot design.	Best applications are high volume and higher sediment food products.

GAS OR ELECTRIC FRYERS?

EQUIPMENT	DESCRIPTION
GAS OPEN POT	
	<p>PICTURE OF GAS OPEN POT DESIGN SHOWING COOK, HEAT, AND COLD ZONE OR SEDIMENT ZONE Local utility costs will determine the cost to operate gas units.</p> <p>Efficiency of heat transfer depends on the type of burner</p> <ul style="list-style-type: none"> - Infrared — high efficiency - Atmospheric — lower efficiency
GAS TUBE POT	
	<p>PICTURE OF GAS TUBE FRYPOT SHOWING COOK, HEAT, AND COLD ZONE OR SEDIMENT ZONE Local utility costs will determine the cost to operate gas units.</p> <p>Efficiency of heat transfer depends on tube size and baffle system</p> <ul style="list-style-type: none"> - 6" tubes/proprietary baffles — high efficiency - 4" or 4" + tubes/standard baffles — lower efficiency
ELECTRIC POT	
	<p>PICTURE OF ELECTRIC OPEN POT DESIGN SHOWING COOK, HEAT, AND COLD ZONE OR SEDIMENT ZONE Local utility costs will determine the cost to operate electric units.</p> <p>Electric units have more efficient heat transfer and faster recovery between frying cycles than gas open pot and tube units as the ribbon-type elements offer a larger surface area for heat to transfer directly into the oil.</p>

WHAT TYPE OF CONTROLS?

Frymaster offers many different types of controllers. If you have a high volume operation and want to ensure all employees will fry consistently to the same quality specifications, then the more advanced controls that offer compensation or “stretch” cooking would be the controllers of choice.

EQUIPMENT	DESCRIPTION	COOKING PERFORMANCE	MODEL OPTIONS
	<p>FQ4000 EASYTOUCH CONTROLLER* Touchscreen operation of cooking and fully-automatic filtration. Times the cook operation and signals visually and audibly when cook is complete. Controller operates the Automatic Top Off (ATO) feature. Controller helps manage oil through SmartFiltration, which prompts user when it is time to filter. Onscreen, step-by-step prompts guide users through important functions, such as filtration, oil disposal, and boil out. Offers recipe configuration and management at the fryer or remotely with easy uploads of menu changes. Built-in connectivity supports operations management, including remote software updates.</p>	<p>Compensation or “stretch” cooking ensures the exact heat load will be utilized for each cook. The result is more consistent and higher quality food products.</p>	<p>FQ30, FQ60</p>
	<p>3000 CONTROLLER* Operates standard built-in filtration. Offers push button cooking for 20 products. Times the cook operation and signals audibly when cooking is complete. Can display Fahrenheit or Celsius temperature values and stores the current time and temperature settings when the unit is turned off. Features temperature check, boil-out, melt cycle and lighted digital display. Controller operates the ATO-Automatic Top Off feature. Controller can monitor oil management functions such as cook counts, prompt when it is time to filter, and guide workers through step-by-step oil management functions such as filtration, oil dispose and boil out. Also can be programmed for segmented cooking, used to cook bone-in chicken.</p>	<p>Compensation or “stretch” cooking ensures the exact heat load will be utilized for each cook. The result is more consistent and higher quality food products.</p>	<p>OCF30, LHD65, 1814, RE80, HD50, HD60</p>
	<p>3010 CONTROLLER* Operates standard built-in filtration. Offers push button cooking for 10 products. Times the cook operation and signals audibly when cooking is complete. Can display Fahrenheit or Celsius temperature values and stores the current time and temperature settings when the unit is turned off. Features temperature check, boil-out, melt cycle and lighted digital display. Controller operates the ATO-Automatic Top Off feature. Controller can monitor oil management functions such as cook counts, prompt when it is time to filter, and guide workers through step-by-step oil management functions such as filtration, oil dispose and boil out. Also can be programmed for segmented cooking, used to cook bone-in chicken.</p>	<p>Compensation or “stretch” cooking ensures the exact heat load will be utilized for each cook. The result is more consistent and higher quality food products.</p>	<p>OCF30, LHD65, 1814, RE80, HD50, HD60</p>
	<p>LANE CONTROLLER Times the cook operation and signals audibly when cooking is complete. Automatically selects Fahrenheit/Celsius temperature values and stores the current time and temperature settings when the unit is turned off. The 3-Lane controller has 10 programmable product buttons, a 40-product library feature, temperature check, boil-out, melt cycle, hold timers, cook compensation and lighted digital display. Control operates as a lane controller with the ability to select not only the product, but also where it will cook, lane 1, 2 or 3. A 2-lane version is available for the HD50 gas and RE electric fryers in the 1814 battery.</p>	<p>Compensation or “stretch” cooking ensures the exact heat load will be utilized for each cook. The result is more consistent and higher quality food products.</p>	<p>1814</p>
	<p>CM3.5 CONTROLLER* Smooth, touch-pad surface; multi-product programmable controller automatically stretches cook time to provide consistent food quality regardless of the product load. LEDs display cooking time countdown (with audible alarm) and provide precise frypot temperature checks. The unit also features controlled boil-out at a steady 195°F (80°C), recovery “test time”, programmable “shake” and “hold” times and more. Available for full or split-pot fryers.</p>	<p>Compensation or “stretch” cooking ensures the exact heat load will be utilized for each cook. The result is more consistent and higher quality food products.</p>	<p>1814, H55, H55-2, RE14, RE14-2, RE17, RE17-2, RE80, HD50G, HD60G, PR50</p>
	<p>DIGITAL TIMER CONTROLLER* Touch-pad control panel is easy to operate for cooking and has timer function. Easy to operate with constant temperature display and timer function for cooks. Features 20 pre-programmed product buttons & timer function.</p>		<p>1814, H55, H55-2, RE14, RE14-2, RE17, RE17-2, RE80, HD50G, HD60G, PR50</p>
	<p>THERMATRON CONTROLLER Standard controller for many Dean fryers. Simple to operate with on/off switch, temperature set dial and melt cycle and boil-out options.</p>		<p>HD50G, HD60G, D60G, PR50, LHD65</p>
	<p>MILLIVOLT CONTROLLER Basic thermostat controller that gets energy from the gas flame. Requires no electrical hook-up.</p>		<p>ESG35T, MJ40, MJ50 MJCF GF14, GF40, SR142, SR152, SR162, PR50, SR14E</p>

*Basket lifts only available with CM3.5, 3000, 3010, and easyTouch controllers.

BUILT-IN FILTER SYSTEM ANNUAL OIL SAVINGS

NO FILTERING

Oil life will be very short and cost of oil replacement will dramatically increase the cost of ownership.

PORTABLE FILTER

Oil life will be extended and reduce cost of ownership over not filtering oil. Portable filtering can be very time consuming and labor intensive.

BUILT-IN FILTERING SYSTEM

A built-in filtering system will provide the maximum oil life which will dramatically reduce the cost of ownership. Filtering is much less labor intensive than utilizing portable filtration units. Filtering can also be done quickly and easily when required.

NUMBER OF 50-LB. (25L) FRYPOTS FILTERED	STANDARD OIL		
	ANNUAL OIL COSTS WITH NO FILTRATION	ANNUAL COST WITH FILTRATION*	ANNUAL PAYBACK
1	\$6,120	\$3,060	\$3,060
2	\$12,240	\$6,120	\$6,120
3	\$18,360	\$9,180	\$9,180
4	\$24,480	\$12,240	\$12,240
5	\$30,600	\$15,300	\$15,300
6	\$36,720	\$18,360	\$18,360

*Savings based on the following (in CAD \$):

Oil costs of \$2.14/L for standard oil. Oil changed 2x/week without filtration and 1x/week with filtration.

ENERGY STAR ANNUAL ENERGY SAVINGS

NON ENERGY STAR UNITS

Lower cost of purchasing but higher cost of ownership. Pay less upfront and more to operate the fryer during its lifetime.

ENERGY STAR UNITS

Higher cost of purchasing but lower cost of ownership. Pay more upfront and less to operate the fryer during its lifetime.

MODEL	SR52* PER POT	H55** PER POT
ENERGY STAR	No	Yes
BTU/HR. INPUT	120k	80k
OIL CAPACITY (LBS.)	50	50
LBS. FRIES/HR	65	70
ENERGY COST/YR	\$3,625	\$2,120
OIL COST/YR. @ \$.75/LB.	\$8,355	\$5,615
ANNUAL COST/YR	\$11,980	\$7,735
ANNUAL SAVINGS	Per Pot	\$4,245 (35%)

Saving Potential: \$4,245 + per year / pot!

Frymaster®

FilterQuick® with FQ4000 easyTouch® Controller Automatic Filtration and Optional Oil Quality Sensor

Gas Fryers

Fingertip Filtration Plus:

40% Less Oil, 10% Less Energy, Outstanding Results



- 30-lb and 60-lb open frypot design** requires 40% less oil and ensures quick and easy cleaning. Saves money, time and labor.
- Independent frypot construction** allows convenient frypot repairs in the field, if needed.
- State-of-the-art combustion** fuels efficiency. Infrared heat transfer qualifies fryers for energy-saving rebates.
- FQ4000 easyTouch® Controller** has operation management features that monitor and help control food quality, oil life, and equipment performance. Offers configurable and customizable recipe management, and connectivity compatible.



- Fingertip, closed cabinet, fully-automatic filtration** starts with easy touch operating actions.
 - Safe technology ensures only one frypot can drain at a time. Filtration is as easy as pushing a button.
 - The filter pump agitates the oil in the frypot before draining to lift the crumbs from the bottom of the frypot, aiding their removal.
 - The blower cools the frypot when draining.
 - The frypot begins heating as soon as a safe level of oil returns to the frypot to speed return to set temperature.
 - The pump is protected by a pressure relief valve for bulk oil systems.

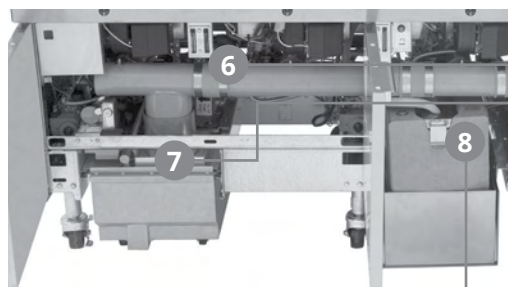

- Optional Oil Quality Sensor (OQS)** monitors the oil's health and advises when to discard. No more guesswork.
- Innovative safety features** offer proprietary advantages over other fryers that prevent simultaneous vat filtrations.
- Automatic Top-Off (ATO) feature** senses the oil level and adds oil as needed from an in-cabinet supply.



FilterQuick® fryers exceed ENERGY STAR® guidelines for high-efficiency and are part of the Welbilt EnerLogic® program.



FRYMASTER OIL-CONSERVING FILTERQUICK 30 SERIES II GAS FRYERS WITH FULLY-AUTOMATIC FILTRATION

FILTERQUICK 30 FRYER BATTERIES — With filtration, FQ4000 easyTouch controller, auto top-off, stainless steel frypots, doors and sides.

MODEL	FQ4000 CONTROLLER*	OIL CAPACITY LBS.	COOK AREA W" X L" X D"	BTU/HR INPUT	SHIPPING WEIGHT LBS.
2FQG30U	\$51,940	(2) 30	(2) 13 x 14 x 3-3/4	(2) 70,000	575
3FQG30U	\$68,405	(3) 30	(3) 13 x 14 x 3-3/4	(3) 70,000	723
4FQG30U	\$89,435	(4) 30	(4) 13 x 14 x 3-3/4	(4) 70,000	980

*with FilterQuick FQ4000 easyTouch controller. NOTES: Basket Lifts — Add \$4,915 for each frypot. | Casters included in pricing.

STANDARD ACCESSORIES

- FilterQuick Filtration with ATO
- Casters
- Rack-type Basket Support
- Bottom Splash Shield
- Covers
- Basket Hanger
- Twin Baskets
- Filter Starter Kit
- Oil Management Package*
- 4GPM Pump
- Jug in Box (JIB) Holder
- Bulk Oil (dispose & fresh fill)

*Oil Management Package included at no extra charge. Includes: set up for bulk oil.

FRYMASTER GAS LINE INFORMATION

1-1/2" gas supply line required. Batteries units (2 or more) require 1" NPT connection Gas inlet size (I.D.) should be no smaller than that provided for connection to the fryers. See service manual and/or plumbing codes for proper pipe sizing.

PART #	DESCRIPTION	PRICE
FRYER ACCESSORIES		
8030099	Basket, Full Size — 12-3/8 x 12-7/8 x 5-1/4 (Can't Be Used w/ Basket Lifts)	\$585
8030438	Basket, Triplet — 4-1/4 x 13-1/4 x 5-1/2	\$400
8030271	Basket, Twin Size — S 5-7/8 x 12-5/8 x 6-5/8	\$400
8030429	Brush, L-Shaped Tampico 21" L x 2" Diameter	\$195
8238859	Chicken/Fish Tray, Full Pot 12 W x 13-3/8 D	\$755
8030388	Clean-Out Rod — 26" Long	\$250
8233938	Crumb Scoop — 1-1/4 W x 6-1/2 D x 22-3/4 H	\$280
8238066	Fish Plate, Full Pot — 12" x 13-3/8" x 3/8"	\$725
8030059	Fish Scoop 8-1/8 W x 8-1/2 D w/ 17-3/8 Handle	\$290
8030446	Fish Skimmer, No Hooks 6" Square w/ Insulated Handle	\$280
	Foam Deck Basket Banger*	\$455/ FRYPOT
8061698	Quick Disconnect Hose 1" Gas Line, 36" Long	\$1,255
8061699	Quick Disconnect Hose 1" Gas Line, 48" Long	\$1,345
8030511	Sediment Tray, Full Pot — 11-7/8 x 15-1/4 x 6-1/2	\$985
8238224	Splash Shield, Side — 19-1/2 W x 11-3/4 H	\$565

*If ordered after fryer purchase, requires changing top connecting strip(s).

DESCRIPTION	PRICE
SPECIAL OIL OPTIONS	
Semi-solid / solid shortening*	\$4,330
Front oil discharge (Precludes bulk rear oil discharge)	SPECIFY WHEN ORDERED
Oil Quality Sensor* MUST call Customer Service before ordering	\$3,910
*Must be requested at time of order.	
SPREADERS — ADD TO PRICE OF FRYER BATTERY	
Spreader Cabinet — Call Customer Service for availability and placement.	\$2,405

PART #	DESCRIPTION	PRICE
FILTERING ACCESSORIES		
8030002	Filter Powder (80, 1oz. Packs)	\$245
8030445	Filter Paper (16-1/2 x 25-1/2) Box Of 100 Sheets	\$290

NOTES:

- 5 ft. grounded cordset provided.
- If elevation is between 5,000 — 10,000 feet, specify the elevation level. Fryer may not perform at optimum levels above this elevation.
- **DO NOT CURB MOUNT.**
- Any questions or pricing information other than the above should be referred to **Customer Service**.

FRYMASTER HIGH-PRODUCTION OIL-CONSERVING FILTERQUICK 60 SERIES I GAS TUBE FRYERS

FILTERQUICK 60 FRYERS — With filtration, FQ4000 easyTouch controller, stainless steel frypot, door(s), and sides.

MODEL	FQ4000 CONTROLLER*	OIL CAPACITY LBS.	COOK AREA W" X L" X D"	BTU/HR INPUT	SHIPPING WEIGHT LBS.
1FQG60T	\$38,450	63	18 x 14 x 3-3/4	119,000	255
2FQG60T	\$56,745	(2) 63	(2) 18 x 14 x 3-3/4	(2) 119,000	390
3FQG60T	\$75,015	(3) 63	(3) 18 x 14 x 3-3/4	(3) 119,000	645

*Standard with FQ4000 easyTouch Controller.

STANDARD ACCESSORIES

- Electronic Ignition
 - Twin Baskets
 - Rack-type Basket Supports
 - Basket Hangers
- Filter models have:
- Drain Safety Switch
 - Filter Starter Kit
 - Casters
 - 8GPM Pump

PART #	DESCRIPTION	PRICE
--------	-------------	-------

FRYER ACCESSORIES

8030271	Basket, Twin Size — S 5-7/8 x 12-5/8 x 6-5/8	\$400
8030436	Basket, Chicken — 17-3/4 x 12-1/4 x 11	\$990
8030437	Basket, Dual — 8 x 12-5/8 x 7	\$420
8030435	Basket, Full Size — 17-1/2 x 12-7/8 x 6-1/8	\$570
8030357	Basket, Triplet — 4-1/2 x 13-1/4 x 6	\$400
8030380	Basket Support Rack, Full Pot, 1FQG60 13-5/8 W x 18 D	\$280
8030197	Clean-Out Rod — 27" Long	\$250
1081872	Cover, Stainless Steel, Full Pot, 1FQG60 21-3/8 W x 19-1/2 D	\$565
2208966	Fish Plate, Full Pot, 1FQG60 — 18 W x 13-5/8 D	\$790
8030059	Fish Scoop — 8-1/8 W x 8-1/2 D w/ 17-3/8 Handle	\$290
8030446	Fish Skimmer, No Hooks 6" Square w/ Insulated Handle	\$280
	Foam Deck Basket Banger*	\$455/ FRYPOT
8061698	Quick Disconnect Hose — 1" Gas Line, 36" Long	\$1,255
8061699	Quick Disconnect Hose — 1" Gas Line, 48" Long	\$1,345
8061701	Quick Disconnect Hose — 3/4" Gas Line, 36" Long	\$1,015
8061700	Quick Disconnect Hose — 3/4" Gas Line, 48" Long	\$1,105
1086187	Sediment Tray — 17-3/4 x 13-5/8 x 11	\$1,160
8237619	Splash Shield — 21-3/8 D x 7-7/8 H	\$565
2102681	Top Connecting Strip — 2 W x 21-3/8 D	\$350

*If ordered after fryer purchase, requires changing top connecting strip(s).

SPREADERS — ADD TO PRICE OF FRYER(S)

Spreader Cabinet — Call Customer Service for availability and placement. **\$2,695**

FRYMASTER GAS LINE INFORMATION

1-1/2" gas supply line required. Each single unit requires a 3/4" NPT connection; battered units (2 or more) require a 1" NPT connection. Gas inlet size (I.D.) should be no smaller than that provided for connection to the fryers. See service manual and/or plumbing codes for proper pipe sizing.

DESCRIPTION	PRICE
-------------	-------

EXTERNAL OIL DISCHARGE OPTIONS

External oil discharge — available on built-in filter batteries of 2 or more frypots or a frypot and spreader. Must specify front or rear connection. Front connection comes with 5ft. washdown hose.	FRONT \$2,730
	REAR \$2,090
Bulk oil (dispose and fresh fill) on batteries with built-in filtration*	\$4,305
Auto Topoff with side saddle* (requires additional 3" space)	\$4,460
Auto Topoff with external 6 foot hose* (no side saddle)	\$2,870

*Must be requested at time of order.

SPECIAL OIL OPTIONS

Semi-solid / solid shortening* Call customer service before ordering	\$4,330
Oil Quality Sensor* MUST call Customer Service Before Ordering	\$3,910

*Must be requested at time of order.

PART #	DESCRIPTION	PRICE
--------	-------------	-------

FILTERING ACCESSORIES

8030002	Filter Powder (80, 1oz. Packs)	\$245
8030289	Filter Paper (22 x 34) Box Of 100 Sheets	\$470
8239116	Filter Screen (High Sediment) 8-1/4 W x 14 D, 2 Required	\$675/ EACH

NOTES:

- Add **\$4,915** /frypot for basket lifts.
- If elevation is between 2,000 — 6,000 feet, specify the elevation level. Fryer may not perform at optimum levels above this elevation.
- **DO NOT CURB MOUNT.**
- Any questions or pricing information other than the above should be referred to Customer Service

Frymaster®

1814 High-Production, with Oil-Conserving, Gas Fryers

Conserve Oil, Energy, & Space



Model shown: 11814/HD50G/11814

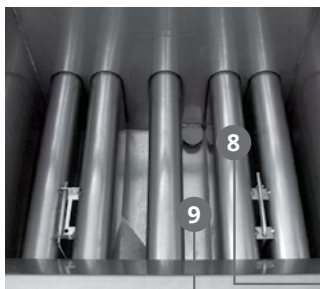

1. **Use 11-15% less hood and floor space** than standard fryer systems.
2. **Use upwards of 50% less energy** than comparable standard fryer systems
3. **Use less oil** reducing operating costs and environmental impact.
 - **16-20% less** than 3 standard 50-lb fryers (126 lbs of oil vs 150 lbs)
 - **12-14% less** than 4 standard 50-lb fryers (176 lbs of oil vs 200 lbs)
4. **Deliver flexible, high-production cooking** with one or two 18" x 14" 3-3/4" cooking area(s) that can cook three baskets of food at the same time. Each 18" x 14" x 3-3/4" frypot can produce:
 - **118 lbs.** of frozen chicken nuggets/hr
 - **100 lbs.** of French fries/hr
 - **74 lbs.** of fresh-breaded chicken strips/hr
 - **68 lbs.** of dry dredge catfish/hr
 - **96 pieces** of fresh-breaded, 8-piece cut chicken/hr
 - **77 lbs.** of wings/hr (875 pieces)
5. **Control food and oil quality with the SMART4U® Lane Controller**, which has programmable cook buttons and features that make it easy to produce consistent, great-tasting food. Digital CM3.5 and 3000 controller are also available.
6. **Save on equipment costs.**
 - Two 1814 fryers do the work of three 50-lb fryers.
 - Two 1814 & one HD50 do the work of four 50-lb fryers.
7. **Support Oil Station Management** with built-in filtration options, making it easy to preserve oil life and ensure consistent, great tasting food. 8 GPM pump quickly remove crumbs and sediment, making the filter process quick and effective.
8. **Optimize Heat Transfer** with 6" vs. 4" diameter tubes, which provide a 36% larger surface for oil contact.
9. **Handle High-Sediment Food with Ease.** Slopping bottom ensures fast drainage and easy cleaning.



1814 models meet ENERGY STAR® guidelines. All 1814 fryers are part of the Welbilt EnerLogic™ energy program.

6679 7/18 ©2018 Frymaster All rights reserved.

FRYMASTER HIGH-PRODUCTION OIL-CONSERVING 1814 GAS TUBE FRYERS

1814 FRYERS — Without filtration with stainless steel frypot, door, and sides.

MODEL	DIGITAL TIMER CONTROLLER	CM3.5 CONTROLLER	LANE CONTROLLER*	OIL CAPACITY LBS.	COOK AREA W" X L" X D"	BTU/HR INPUT	SHIPPING WEIGHT LBS.
11814G	\$12,635	\$14,500	\$16,005	63	18 x 14 x 3-3/4	119,000	255

1814 FRYERS — With filtration with stainless steel frypot, door(s), and sides.

MODEL	DIGITAL TIMER CONTROLLER	CM3.5 CONTROLLER	LANE CONTROLLER*	OIL CAPACITY LBS.	COOK AREA W" X L" X D"	BTU/HR INPUT	SHIPPING WEIGHT LBS.
11814GF	\$27,345	\$29,215	\$30,705	63	18 x 14 x 3-3/4	119,000	390
21814GF	\$41,235	\$44,945	\$47,950	(2) 63	(2) 18 x 14 x 3-3/4	(2) 119,000	645
31814GF	\$55,125	\$60,690	\$65,205	(3) 63	(3) 18 x 14 x 3-3/4	(3) 119,000	900

* Standard with Lane controller. 3000 and 3010 controller can be substituted for Lane controller at no cost.

STANDARD ACCESSORIES

- Electronic Ignition
- Twin Baskets
- Rack-type Basket Supports
- Basket Hangers
- Legs (non-filter models)
- Filter models have:
 - Drain Safety Switch
 - Filter Starter Kit
 - Casters
 - 8GPM Pump

PART #	DESCRIPTION	PRICE
--------	-------------	-------

FRYER ACCESSORIES

8030271	Basket, Twin Size — S 5-7/8 x 12-5/8 x 6-5/8	\$400
8030436	Basket, Chicken — 17-3/4 x 12-1/4 x 11	\$990
8030437	Basket, Dual — 8 x 12-5/8 x 7	\$420
8030435	Basket, Full Size — 17-1/2 x 12-7/8 x 6-1/8	\$570
8030357	Basket, Quad — 4-1/2 x 13-1/4 x 6	\$400
8030380	Basket Support Rack Full Pot, 1FQG60 13-5/8 W x 18 D	\$280
8030278	Brush, L-Shaped Teflon - 26-3/4" L x 1" Diameter	\$245
8030197	Clean-Out Rod — 27" Long	\$250
1081872	Cover, Stainless Steel, Full Pot, 1FQG60 21-3/8 W x 19-1/2 D	\$565
2208966	Fish Plate, Full Pot, 1FQG60 — 18 W x 13-5/8 D	\$790
2400916	Fish Plate, Wet-battered	\$795
8233938	Crumb Scoop — 1-1/4 W x 6-1/2 D x 22-3/4 H	\$280
8030059	Fish Scoop 8-1/8 W x 8-1/2 D w/ 17-3/8 Handle	\$290
8030446	Fish Skimmer — No Hooks 6" Square w/ Insulated Handle	\$280
	Foam Deck Basket Banger*	\$455/ FRYPOT
8061698	Quick Disconnect Hose 1" Gas Line, 36" Long	\$1,255
8061699	Quick Disconnect Hose, 1" Gas Line, 48" Long	\$1,345
8061701	Quick Disconnect Hose 3/4" Gas Line, 36" Long	\$1,015
8061700	Quick Disconnect Hose — 3/4" Gas Line, 48" Long	\$1,105
1086187	Sediment Tray — 17-3/4 x 13-5/8 x 11	\$1,160
8237619	Splash Shield — 21-3/8d x 7-7/8 H	\$565
2102681	Top Connecting Strip — 2 W x 21-3/8 D	\$350

*If ordered after fryer purchase, requires changing top connecting strip(s).

FRYMASTER GAS LINE INFORMATION

1-1/2" gas supply line required. Each single unit requires a 3/4" NPT connection; battered units (2 or more) require a 1" NPT connection. Gas inlet size (I.D.) should be no smaller than that provided for connection to the fryers. See service manual and/or plumbing codes for proper pipe sizing.

DESCRIPTION	PRICE
-------------	-------

EXTERNAL OIL DISCHARGE OPTIONS

External oil discharge — available on built-in filter batteries of 2 or more frypots or a frypot and spreader. Must specify front or rear connection. Front connection comes with 5ft. washdown hose.	FRONT \$2,730
	REAR \$2,090
Bulk oil (dispose and fresh fill) on batteries with built-in filtration*	\$4,305

*Must be requested at time of order.

SPREADERS — ADD TO PRICE OF FRYER(S)

Spreader Cabinet — Call Customer Service for availability and placement.	\$2,695
--	----------------

PART #	DESCRIPTION	PRICE
--------	-------------	-------

FILTERING ACCESSORIES

8030002	Filter Powder (80, 1oz. Packs)	\$245
8030289	Filter Paper (22 x 34) Box Of 100 Sheets	\$470
8239116	Filter Screen (High Sediment) 8-1/4 W x 14 D, 2 Required	\$675/ EACH

NOTES:

- Add \$4,915 /frypot for basket lifts.
- If elevation is between 2,000 — 6,000 feet, specify the elevation level. Fryer may not perform at optimum levels above this elevation.
- **DO NOT CURB MOUNT.**
- Any questions or pricing information other than the above should be referred to Customer Service

Frymaster®

OCF30™ Series Gas Fryers

40% Less Oil, 10% Less Energy,
Outstanding Results

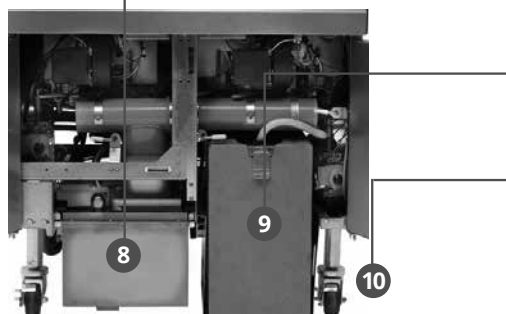
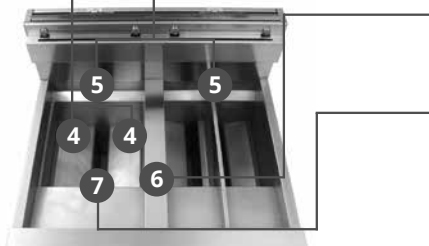

1. **30-lb. open frypot design** requires 40% less oil and ensures quick and easy cleaning. Saves money, time and labor.
2. **SMART4U® 3000 controller** helps control food and oil quality, oil life, and equipment performance.
3. **Sturdy basket hangers** are durable and easy to clean.
4. **State-of-the-art combustion** fuels efficiency. ENERGY STAR® rated infrared heat transfer qualifies fryers for energy-saving rebates.
5. **Robust product line** offers full and split frypots.
6. **Independent frypot construction** allows convenient frypot repairs in the field if needed.
7. **High limit auto reset** requires no tools or operator intervention and an **audible alarm** alerts if a second drain valve is opened.
8. **Built-in Filtration** preserves oil life and ensures consistent, great-tasting food.
9. **Oil Attendant® Auto Fill Option** senses the oil level and adds oil as needed from an in-cabinet supply.
10. **Adjustable leveling casters** accommodate all kitchen designs and floor types.



OCF30G fryers meet ENERGY STAR® guidelines for high efficiency, and all OCF30G fryers are part of the Welbilt EnerLogic™ program.

FRYMASTER OIL-CONSERVING OCF30 GAS FRYERS

OCF30 FRYERS — With filtration, manual top-off stainless steel frypot, door and sides.

MODEL	3000 CONTROLLER*	OIL CAPACITY LBS.	COOK AREA W" X L" X D"	BTU/HR INPUT	SHIPPING WEIGHT LBS.
FPGL130C	\$28,010	30	13 x 14 x 3-3/4	70,000	265

OCF30 FRYER BATTERIES — With filtration, auto top-off stainless steel frypots, doors and sides.

MODEL	3000 CONTROLLER*	OIL CAPACITY LBS.	COOK AREA W" X L" X D"	BTU/HR INPUT	SHIPPING WEIGHT LBS.
FPGL230CA	\$48,105	(2) 30	(2) 13 x 14 x 3-3/4	(2) 70,000	544
FPGL330CA	\$65,970	(3) 30	(3) 13 x 14 x 3-3/4	(3) 70,000	723

*Standard with 3000 controller. Can substitute 3010 controller for no additional cost.

NOTES: Split frypots — Add \$4,915 for each split frypot. | Basket Lifts — Add \$4,915 for each frypot.
Casters included in pricing. | Tandem basket lifts — Add \$180 each frypot (full or split).

STANDARD ACCESSORIES

- Built-in Filtration with ATO
- Casters
- Rack-type Basket Support
- ATO (except FPGL130C)
- Basket Hanger
- Twin Baskets
- Filter Starter Kit
- Jug in Box (JIB) Holder

PART #	DESCRIPTION	PRICE
--------	-------------	-------

FRYER ACCESSORIES

8030099	Basket, Full Size — 12-3/8 x 12-7/8 x 5-1/4 (Can't Be Used w/ Basket Lifts)	\$585
8030438	Basket, Triplet — 4-1/4 x 13-1/4 x 5-1/2	\$400
8030271	Basket, Twin Size — 5-7/8 x 12-5/8 x 6-5/8	\$400
8030375	Basket Support Rack, Full Pot 11-7/8 W x 13-1/2 D	\$290
8030429	Brush, L-Shaped Tampico 21" L x 2" Diameter	\$195
8238859	Chicken/Fish Tray, Full Pot — 12 W x 13-3/8 D	\$755
8238224	Splash Shield, Side 19 — 1/2 W x 11-3/4 H	\$565
8238897	Cover, Stainless Steel, Full Pot 14-5/8 W x 21 D	\$565
8030197	Clean-Out Rod — 27" Long	\$250
8233938	Crumb Scoop — 1-1/4 W x 6-1/2 D x 22-3/4 H	\$280
8238066	Fish Plate, Full Pot — 12" x 13-3/8" x 3/8"	\$725
8030059	Fish Scoop 8-1/8 W x 8-1/2 D w/ 17-3/8 Handle	\$290
	Foam Deck Basket Banger*	\$455/ FRYPOT
8030446	Fish Skimmer — No Hooks 6" Square w/ Insulated Handle	\$280
8061698	Quick Disconnect Hose 1" Gas Line, 36" Long	\$1,255
8061699	Quick Disconnect Hose 1" Gas Line, 48" Long	\$1,345
8030511	Sediment Tray, Full Pot 11-7/8 x 15-1/4 x 6-1/2	\$985
8238898	Covers, Split Pot	\$340

*If ordered after fryer purchase, requires changing top connecting strip(s).

FRYMASTER GAS LINE INFORMATION

1-1/2" gas supply line required. Battered units (2 or more) require 1" NPT connection Gas inlet size (I.D.) should be no smaller than that provided for connection to the fryers. See service manual and/or plumbing codes for proper pipe sizing.

DESCRIPTION	PRICE
-------------	-------

EXTERNAL OIL DISCHARGE OPTIONS

Bulk Oil (dispose and fresh fill)* (Not Available For FPGL130C)	\$2,730
Semi-solid / solid shortening* — Call customer service before ordering	\$4,330

*Must be requested at time of order.

SPREADERS — ADD TO PRICE OF FRYER(S)

Spreader Cabinet — Call Customer Service for availability and placement.	\$2,405
--	---------

PART #	DESCRIPTION	PRICE
--------	-------------	-------

FILTERING ACCESSORIES

8030002	Filter Powder (80, 1oz. Packs)	\$245
8030445	Filter Paper (16-1/2 x 25-1/2) Box Of 100 Sheets	\$290

NOTES:

- 5 ft. grounded cordset provided.
- If elevation is between 5,000 — 10,000 feet, specify the elevation level. Fryer may not perform at optimum levels above this elevation.
- DO NOT CURB MOUNT.
- Any questions or pricing information other than the above should be referred to Customer Service

Frymaster®

ESG35T ENERGY STAR® Value, High-Efficiency Fryer Saves Energy and Oil.

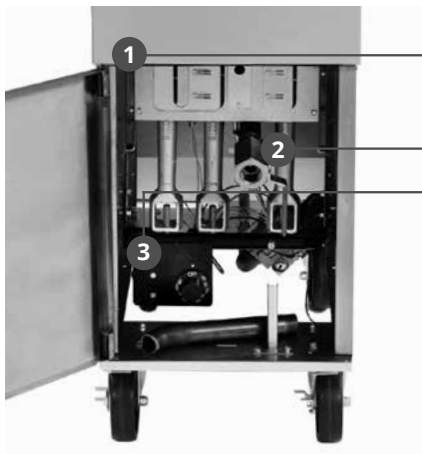

1

1. **High-efficiency.** Exceeds ENERGY STAR® guidelines and qualifies for energy saving rebates.

2

2. **Requires 33% less BTU/hr** than comparable standard models.

3

3. **Millivolt Control** - no electrical hook-up required.

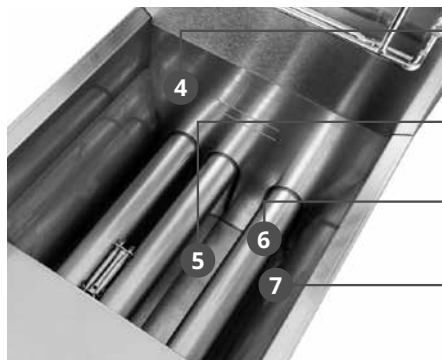

4

4. **22% less oil.** 35-lb. frypot produces as much food as a 45-lb. fryer.

5

5. **Wide cold zone** keeps crumbs and sediment away from cooking areas.

6

6. **6-inch heating tubes** along with a proprietary baffle design deliver superior heat transfer.

7

7. **Insulated frypot** allows for a low idle rate further enhancing energy savings.



8

8. **Reduced flue heat.** 27% Less.

9

9. **Stainless steel** frypot, front door, back splash and flue.



ESG35T fryers exceed ENERGY STAR® guidelines for high efficiency and are part of the Welbilt EnerLogic™ program

FRYMASTER ESG35T ENERGY STAR® VALUE GAS FRYER

ESG35T FRYERS — Without filtration, with stainless steel frypot, door and sides.

MODEL	MILLIVOLT CONTROLLER	OIL CAPACITY LBS.	COOK AREA W" X L" X D"	BTU/HR INPUT	SHIPPING WEIGHT LBS.
ESG35T	\$3,905	35	14 x 13-3/4 x 4-1/5	70,000	165

STANDARD ACCESSORIES

- Legs
- Rack-type Basket Support
- Basket Hanger
- Twin Baskets

PART #	DESCRIPTION	PRICE
--------	-------------	-------

FRYER ACCESSORIES

8030271	Basket, Twin Size — S 5-7/8 x 12-5/8 x 6-5/8	\$400
8030442	Basket Support Rack 13-1/2" W x 11-1/4" D	\$280
8030429	Brush, L-Shaped Tampico 21" L x 2" Diameter	\$195
8030278	Brush, L-Shaped Teflon — 26-3/4" L x 1" Diameter	\$245
8030197	Clean-Out Rod — 27" Long	\$250
1061637	Cover, Frypot — 13-1/2 W x 21-3/8 D	\$565
	Casters — Set of Four	\$650
2102681	Top Connecting Strip — 2 W x 21-3/8 D	\$350

FRYMASTER GAS LINE INFORMATION

Fryers must be installed with proper size gas line. Each single unit requires a 3/4" NPT connection.

NOTES:

- If elevation is between 2,000-6,000 feet, contact local service agent for elevation kits.
- **DO NOT CURB MOUNT.**
- Any questions or pricing information other than the above should be referred to Customer Service

Frymaster®

LHD65 Low Flue Temperature Gas Fryers

Keep the Kitchen Cool and Production Capacity High



Model shown: FPLHD265 with 3000 controller and optional marine edge and front oil disposal



1. **Have flue temperatures less than 550°F**
2. **Handle heavy loads** of fresh breaded bone-in chicken and other products with an 18"x18"x 5¾" cooking area and 100-lb oil capacity.
 - 128 lbs. fresh breaded 8 piece cut chicken/hr
 - 85 lbs. of dry dredge catfish/hr
 - 140 lbs. of frozen boneless wings/hr
 - 103 lbs. of frozen chicken tenders/hr
 - 650 (2.5 oz) bone-in naked wings/hr
3. Exceed **ENERGY STAR®** guidelines, qualifying for energy saving rebates.
4. **Control food & oil quality** with the **SMART4U®** 3000 controller, which has programmable cook buttons and segmented cook feature, when needed for frying bone-in chicken.
5. **Support oil station management.** Batteries have built-in filtration, making it easy to preserve oil life and ensure consistent, great tasting food. 8 GPM pump quickly removes crumbs and sediment, making the filter process quick and effective.
6. **Optimize heat transfer** with 6" vs. 4" diameter tubes, which provide a 36% larger surface for oil contact and reduce the heat load/sq inch 22% so oil lasts longer.
7. **Handle high-sediment foods with ease.** Large sloping bottom ensures fast drainage and easy cleaning.



All LHD65 fryers meet ENERGY STAR guidelines for high efficiency and are part of the Welbilt EnerLogic program.

FRYMASTER LOW FLUE TEMPERATURE GAS FRYERS

LHD65 FRYERS — Without filtration, with stainless steel frypot, door and sides.

MODEL	THERMATRON CONTROLLER	SMART4U 3000 CONTROLLER*	OIL CAPACITY LBS.	COOK AREA W" X L" X D"	BTU/HR INPUT	SHIPPING WEIGHT LBS.
LHD165	\$14,110	\$18,995	100 lbs	18 x 18 x 5-3/4	105,000	260

LHD65 FRYER BATTERIES — With filtration, stainless steel frypots, doors and sides.

MODEL	THERMATRON CONTROLLER	SMART4U 3000 CONTROLLER*	OIL CAPACITY LBS.	COOK AREA W" X L" X D"	BTU/HR INPUT	SHIPPING WEIGHT LBS.
FPLHD265	\$43,395	\$53,165	(2) 100 lbs	(2) 18 x 18 x 5-3/4	(2) 105,000	750
FPLHD365	\$59,170	\$73,820	(3) 100 lbs	(3) 18 x 18 x 5-3/4	(3) 105,000	1,100

*Standard with 3000 and 3010 controller. NOTES: Filter price included. | Price includes casters.

** Fryers do not come with traditional accessories, these must be ordered. See recommended accessory packages to order.

STANDARD ACCESSORIES

- 3000 Controller
 - Electronic Ignition
 - 11" Plate Shelf with Marine Edge
 - See recommended packages for ordering accessories
- Filter models have:
- Casters
 - Filter Starter Kit
 - 8 GPM Pump
 - Drain Safety Switch

PART #	DESCRIPTION	PRICE
--------	-------------	-------

FRYER ACCESSORIES

8030304	Basket, Twin Size — 8-3/4 x 16-3/4 x 6	\$400
8030427	Basket, Triplet Size — 5-5/8 x 15-7/8 x 7-1/4	\$425
8030148	Basket, Full Size — 16-3/4 x 17-1/2 x 5-3/4	\$610
8235859	Basket Hanger 20 W x 7 H, with Flue Deflectors	\$280
8102235	Basket Support Rack, D60G 17-3/8 W x 17-5/8 D	\$405
8030278	Brush, L-Shaped Teflon 26-3/4" L x 1" Diameter	\$245
	Casters — Set of Four	\$650
8235801	Flue Deflector — 20 W x 9-1/2 H	\$300
8103066	L-Basket Support Rack 17-5/8 W x 17-5/8 D (LHD65)	\$470
8061698	Quick Disconnect Hose 1" Gas Line, 36" Long	\$1,255
8061699	Quick Disconnect Hose 1" Gas Line, 48" Long	\$1,345
8061701	Quick Disconnect Hose 3/4" Gas Line, 36" Long	\$1,015
8061700	Quick Disconnect Hose 3/4" Gas Line, 48" Long	\$1,105
1062631	Sediment Tray, HD60G 17-3/4 W x 17-1/8 D	\$1,160
8235789	Splash Shield	\$405
1062897	Frypot Cover 18 W x 18-1/2 D, Stainless Steel	\$565
8233696	Sediment Scoop	\$180
8233938	Crumb Scoop — 1-1/4 W x 6-1/2 D x 22-3/4 H	\$280
8233947	Chicken/Fish Tray, HD60G 16-1/2 x 16-1/2 x 11	\$810
	Foam Deck Basket Banger*	\$455/ FRYPOT

NOTES:

- If elevation is between 2,000 — 6,000 feet, specify the elevation level. Fryer may not perform at optimum levels above this elevation.
- Any questions or pricing information other than the above should be referred to **Customer Service**

FRYMASTER GAS LINE TABLE

# OF FRYERS	GAS LINE WITHOUT FILTER	GAS LINE WITH FILTER
1	3/4"	3/4"
2-3	N/A	(1) 1"

DESCRIPTION	PRICE
-------------	-------

EXTERNAL OIL DISCHARGE OPTIONS

External oil discharge — available on built-in filter batteries of 2 or more frypots or a frypot and spreader. Must specify front or rear connection. Front connection comes with 5ft. washdown hose.

FRONT \$2,730

REAR \$2,090

PART #	DESCRIPTION	PRICE
--------	-------------	-------

FILTERING ACCESSORIES

8030002	Filter Powder (80, 1oz. Packs)	\$245
8239068	Filter Screen (High Sediment) 10-3/4 x 14, 2 Required	\$675/ EACH
8030293	Gloves, Black Safety	\$175
8233696	Sediment Scoop	\$180
8030289	Filter Paper (22x34) Box of 100 sheets	\$470

RECOMMENDED STANDARD ACCESSORY PACKAGES

STANDARD FRYING	BONE-IN CHICKEN
-----------------	-----------------

- Basket Support Rack(S) (8102235)
- Basket Hanger With Flue Deflector(S) (8235859)
- Dual Size Baskets (8030304)
- L-Basket Support Rack(S) (8103066)
- Flue Deflector(S) (8235801)
- Full Size Basket(S) (8030148)

Recommended Standard Accessories can be ordered per frypot.

Example: FPLHD265 — one standard frying package and one bone-in chicken package.

GAS MANIFOLD REQUIREMENTS

1" Rear Gas Manifold (Per Fryer)	WITH FILTER: With Shut-Off Valve	\$185
	Without Shut-Off Valve	Standard

*If ordered after fryer purchase, requires changing top connecting strip(s).

Tel: 905-624-1419 • 888-442-7526

Fax: 905-624-1851 • 800-361-2724

For more information, visit www.garlandcanada.ca

Frymaster®

High-Efficiency(HD) Gas Fryers

Compete in the Race Against Energy Cost

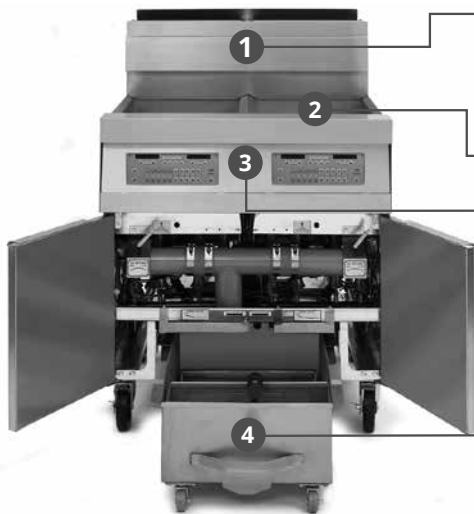

HD260 fryer shown with optional 3000 controller and built-in filtration.

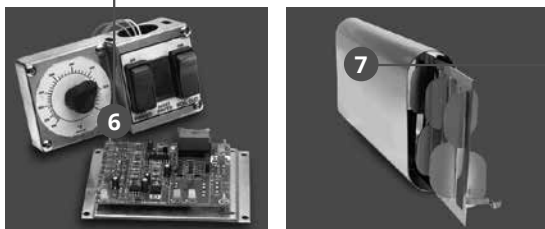
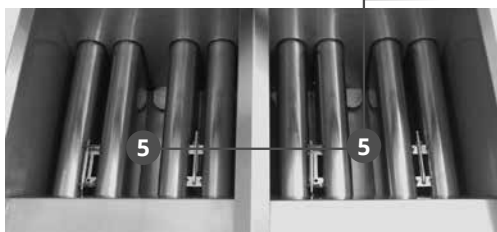

- 1. Are designed for high-volume frying and maximum efficiency.** Rapid, yet controlled heat-up, low idle cost, and low gas consumption per pound of food cooked make the HD gas fryers the MVPs of high-efficiency, tube-type frying.
- 2. Meet a wide range of high-production needs** with models offering from 50 to 100-lb. oil capacities, 3-3/4" to 5-3/4" cooking depths, 100,000 to 125,000 Btu/hr inputs, and 14" x 14" x 3-3/4" to 18" x 18" x 5-3/4" frying areas.
- 3. Handle a wide range of menu items.** HD fryers are ideal for everything from fries to bone-in chicken to other breaded foods, and large-size menu items requiring more frying area.
- 4. Offer easy-to-operate, quick, convenient and reliable filtration option** that maintains food quality, extends the useful cooking life of oil, and saves money.
- 5. Make short work of high-sediment frying.** The wide cold zone traps sediment away from the cooking area, safeguarding the quality of the oil and the foods being cooked. Sloping bottom ensures fast draining and easy cleaning.
- 6. Control food quality** with the Thermatron™ controller's quick response to temperature changes and precise control of cooking temperatures. The optional controllers (Digital*, Electronic Timer*, CM3.5* and SMART4U* 3000) add cooking compensation and count down timers for an elite level of control.
- 7. Provide energy efficiency that translates to savings.** New Thermo-Tube design provides an additional 2" of tube height and 36% more heat transfer surface area. This reduces the heat/sq inch on the oil by 22%, for more efficient heat transfer and longer lasting oil life.

HD Fryers maintain high-production cooking capacity and fast recovery to meet peak demands, while realizing energy savings.

*Not available for CE.



HD50 fryers meet ENERGY STAR® guidelines. All HD fryers are part of the Welbilt EnerLogic energy program.

FRYMASTER HIGH EFFICIENCY DECATHLON (HD) GAS FRYERS

HD FRYERS — Without filtration, with stainless steel frypot, door and sides.

MODEL	THERMATRON CONTROLLER*	CM 3.5 CONTROLLER	3000 CONTROLLER	OIL CAPACITY LBS.	COOK AREA W" X L" X D"	BTU/HR INPUT	SHIPPING WEIGHT LBS.
HD150G	\$9,755	\$13,745	\$14,455	50	14 x 14 x 3-1/2	100,000	180
HD160G	\$11,815	\$16,780	\$17,485	80	18 x 18 x 3-3/4	125,000	255

*Standard with Thermatron controller.

HD50 FRYERS — With filtration, stainless steel frypot(s), door(s) and sides.

MODEL	THERMATRON CONTROLLER*	CM 3.5 CONTROLLER	3000 CONTROLLER	OIL CAPACITY LBS.	COOK AREA W" X L" X D"	BTU/HR INPUT	SHIPPING WEIGHT LBS.
CFHD150G	\$17,985	\$22,955	\$23,660	(1) 50	14 x 14 x 3-1/2	100	354
SCFHD250G	\$32,160	\$40,130	\$41,535	(2) 50	(2) 14 x 14 x 3-1/2	(2) 100,000	575
SCFHD350G	\$43,500	\$55,475	\$57,570	(3) 50	(3) 14 x 14 x 3-1/2	(3) 100,000	800
SCFHD450G	\$54,855	\$70,810	\$73,610	(4) 50	(4) 14 x 14 x 3-1/2	(4) 100,000	1,130

*Standard with Thermatron controller.

NOTES: Filter price included. | Filter price includes casters. | Add \$3,460 /FRYPOT for basket lifts (not available with Thermatron controller.) | 4 GPM pump standard.

HD60 FRYER BATTERIES — With filtration, stainless steel frypot(s), door(s) and sides.

MODEL	THERMATRON CONTROLLER*	CM 3.5 CONTROLLER	3000 CONTROLLER	OIL CAPACITY LBS.	COOK AREA W" X L" X D"	BTU/HR INPUT	SHIPPING WEIGHT LBS.
CFHD160G	\$20,885	\$25,840	\$26,555	(1) 80	(1) 18 x 18 x 3-3/4	(1) 125,000	354
SCFHD260G	\$37,750	\$47,685	\$49,075	(2) 80	(2) 18 x 18 x 3-3/4	(2) 125,000	677
SCFHD360G	\$51,160	\$66,075	\$68,170	(3) 80	(3) 18 x 18 x 3-3/4	(3) 125,000	1,083
SCFHD460G	\$64,580	\$84,455	\$87,250	(4) 80	(4) 18 x 18 x 3-3/4	(4) 125,000	1,403

*Standard with Thermatron controller.

NOTES: Filter price included. | Filter price includes casters. | Add \$3,460 /FRYPOT for basket lifts (not available with Thermatron controller.) | 8 GPM pump standard.

PART #	DESCRIPTION	PRICE
FILTERING ACCESSORIES		
8030293	Gloves, Black Safety	\$175
8233696	Sediment Scoop	\$180
8239068	Filter Screen (High Sediment) 10-3/4 x 14, 2 Required	\$675/ EACH
8030002	Filter Powder (80, 1oz. Packs)	\$245
8030345	60 Fryer, SUFF* Equipped, 33-1/4 x 17 Box Of 100 Sheets	\$470
8030289	Filter Paper (22 x 34) Box Of 100 Sheets	\$470

*SUFF-Equipped systems are single frypots with built-in filtration only.

**UFF-Equipped systems are multi-battered frypots with built-in filtration only.

NOTES:

- If elevation is between 2,000 — 6,000 feet, specify the elevation level. Fryer may not perform at optimum levels above this elevation.
- Any questions or pricing information other than the above should be referred to **Customer Service**

STANDARD ACCESSORIES

- Electronic Ignition
- Automatic Melt Cycle
- Boil-out Temperature Control
- Legs (non-filter models)
- Rack-type Basket Support
- Basket Hanger
- Twin Baskets
- Drain Safety Switch
- Casters (filter models)

DESCRIPTION	PRICE
-------------	-------

EXTERNAL OIL DISCHARGE OPTIONS

External oil discharge — available on built-in filter batteries of 2 or more frypots or a frypot and spreader. Must specify front or rear connection. Front connection comes with 5ft. washdown hose.

FRONT \$2,730

REAR \$2,090

SPREADERS — ADD TO PRICE OF FRYER(S)

HD50G — 15MC	\$1,980
HD60G — 20MC	\$2,695

NOTE: Call Customer Service for availability and placement.

FRYMASTER HIGH EFFICIENCY DECATHLON (HD) GAS FRYERS

GAS MANIFOLD REQUIREMENTS

1" Rear Gas Manifold (per fryer)	WITH FILTER: with shut-off valve	\$185
	without shut-off valve	STANDARD

FRYMASTER GAS LINE TABLE

# OF FRYERS	GAS LINE WITHOUT FILTER	GAS LINE WITH FILTER
1	3/4"	3/4"
2-3	N/A	(1) 1"

PART #	DESCRIPTION	PRICE
--------	-------------	-------

FRYER ACCESSORIES

8030099	Basket, Full Size — 12-3/8 x 12-7/8 x 5-1/4 (Can't Be Used w/ Basket Lifts)	\$585
8030017	Basket, Full Size, HD60G — 17-1/2 x 16-3/4 x 6	\$610
8030357	Basket, Triplet, HD50G — 4-1/2 x 13-1/4 x 6	\$400
8030427	Basket, Triplet Size, HD60G — 5-5/8 x 15-7/8 x 7-1/4	\$425
8030271	Basket, Twin Size — S 5-7/8 x 12-5/8 x 6-5/8	\$400
8030304	Basket, Twin Size, HD60G — 8-3/4 x 16-3/4 x 6	\$400
8030273	Basket Support Rack, HD50G — 13-1/2 W x 13-1/4 D	\$280
8102235	Basket Support Rack, HD60G — 17-3/8 W x 17-5/8 D	\$405
8030277	Basket Support Rack, Fine Mesh, HD50G — 13-1/2 W x 13-1/4 D	\$340
8030149	Basket Support Rack, Fine Mesh, HD60G — 17 W x 17 D	\$400
8030278	Brush, L-Shaped Teflon — 26-3/4" L x 1" Diameter	\$245
2208963	Chicken/Fish Tray, HD50G	\$725
8233947	Chicken/Fish Tray, HD60G — 16-1/2 x 16-1/2 x 11	\$810
8030197	Clean-Out Rod — 27" Long	\$250
1061637	Cover, Frypot, HD50G — 13-1/2 W x 21-3/8 D	\$565
1061479	Cover, Frypot w/o Basket Lift, HD60G — 23-3/8 W x 19-3/4 D	\$665
1062734	Cover, Frypot With Basket Lift, HD50G — 14-1/4 W x 20-1/2 D	\$530
1062773	Cover, Frypot With Basket Lift, HD60G — 18 W x 22-5/8 D	\$665
8030059	Fish Scoop — 8-1/8 W x 8-1/2 D w/ 17-3/8 Handle	\$290
8030446	Fish Skimmer — No Hooks 6" Square w/ Insulated Handle	\$280
	Foam Deck Basket Banger*	\$455/FRYPOT
8061698	Quick Disconnect Hose — 1" Gas Line, 36" Long	\$1,255
8061699	Quick Disconnect Hose — 1" Gas Line, 48" Long	\$1,345
8061701	Quick Disconnect Hose — 3/4" Gas Line, 36" Long	\$1,015
8061700	Quick Disconnect Hose — 3/4" Gas Line, 48" Long	\$1,105
1064136	Sediment Tray, HD50G — 13-1/2 W x 13-3/4 D	\$985
1062631	Sediment Tray, HD60G — 17-3/4 W x 17-1/8 D	\$1,160
8233225	Splash Shield, HD50G — 21-1/2 D x 13 H	\$340
8235744	Splash Shield, HD60G	\$340
2102681	Top Connecting Strip — 2 W x 21-3/8 D	\$350
2105086	Top Connecting Strip, HD60G — 2 W x 23-5/8 D	\$350
	8 Gpm Pump Option — HD50	\$930

*If ordered after fryer purchase, requires changing top connecting strip(s).

Frymaster®

H55 Gas Fryers

Set the Standard for High-Efficiency,
Open-Port Frying

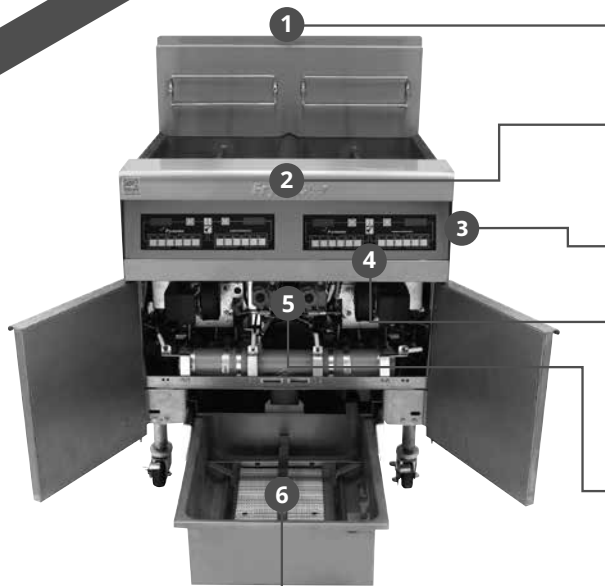

1. **Combine state-of-the-art combustion technology with decades of frying experience** to set a world standard for high-efficiency frying.
2. **Are the industry's first GREEN fryers**, meeting ENERGY STAR® standards long before any standards were established. H55 fryers are the foundation of Frymaster's ever evolving conserving fryer technology.
3. **Qualify for energy-saving rebates.**
4. **Ensure consistent, great-tasting food.** RTD, center-mounted temperature probe and digital controller deliver precise heat responses, safeguarding oil life and producing a uniformly-cooked product. Controller (CM3.5 and SMART4U® 3000) and basket lift options provide additional cooking control. The CM3.5 and 3000 controller options offer cooking compensation.
5. **Have a renowned infrared burner and blower system** that delivers an ultra-refined air-gas mixture so the fryer operates well in any gas application.
 - High altitudes
 - Sub-optimal air circulation environments
 - When gas heating quality is diminished

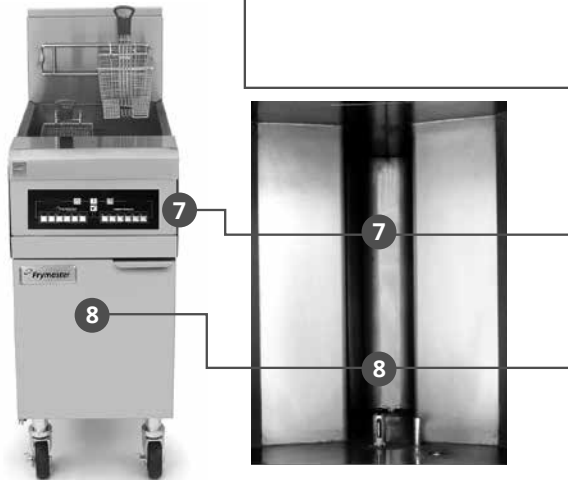

6. **Offer easy-to-operate, quick, convenient and reliable filtration options** that maintain food quality, extend the useful cooking life of oil, and save money. Built-in filtration supports a regular program of filtration proven to dramatically extend oil life, saving thousands of dollars annually on oil costs.
7. **Offer standard features that add convenience and ease of use.**
 - Open frypot is easy to clean
 - Electronic ignition (no pilot to light), melt cycle mode, and boil-out mode
8. **Protect purchases with an unmatched 7-Year Warranty** that covers the entire combustion chamber (frypot, infrared burners, and combustion components).

H55 fryers have been tested by time and are trusted by operators worldwide.

Frymaster[®]

H55 Exclusive 7-Year Warranty

Protects Your H55 Purchase

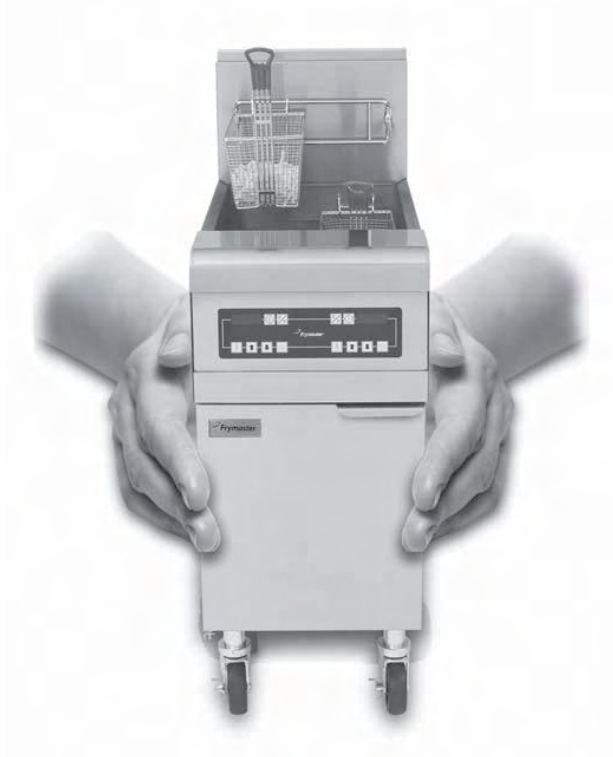

Frymaster's #1 selling fryer has a 7-Year Warranty that is unmatched in the industry.

The 7-Year Warranty covers the entire combustion chamber.

Frymaster's exclusive warranty protects your H55 purchase investment by:

- **Covering the Parts and Labor costs** on the combustion chamber for 7 years (frypot, infrared burners and combustion components).
- **Offering this enhanced protection at NO ADDITIONAL COST!**
- **Lowering your overall maintenance and repair costs.**

FRYMASTER HIGH EFFICIENCY H55 GAS FRYERS

H55 FRYER — Without filtration, with stainless steel frypot, door and sides.

MODEL	DIGITAL TIMER CONTROLLER	CM 3.5 CONTROLLER*	OIL CAPACITY LBS.	COOK AREA W" X L" X D"	BTU/HR INPUT	SHIPPING WEIGHT LBS.
PH155	\$12,140	\$14,980	50	14 x 15 x 4-1/2	80,000	202

*Standard with CM3.5 controller.

H55 FRYER BATTERIES — With filtration, stainless steel frypots, door(s) and sides.

MODEL	DIGITAL TIMER CONTROLLER	CM 3.5 CONTROLLER*	OIL CAPACITY LBS.	COOK AREA W" X L" X D"	BTU/HR INPUT	SHIPPING WEIGHT LBS.
FPH155	\$22,945	\$25,740	(1) 50	(1) 14 x 15 x 4-1/2	(1) 80,000	306
FPPH255	\$36,030	\$41,655	(2) 50	(2) 14 x 15 x 4-1/2	(2) 80,000	492
FPPH355	\$49,280	\$57,705	(3) 50	(3) 14 x 15 x 4-1/2	(3) 80,000	671
FPPH455	\$62,540	\$73,775	(4) 50	(4) 14 x 15 x 4-1/2	(4) 80,000	881

*Standard with CM3.5 controller.

NOTES: Filter price included. | Price includes casters. | Add **\$3,275** for each split frypot | Add **\$4,375** /FRYPOT for basket lifts.
 Standard supplies for all filter systems consist of sample packages of filter powder and paper, one filter brush and one clean-out rod.
 Tandem basket lifts — Add **\$180** each frypot (full or split).

STANDARD ACCESSORIES

- Electronic Ignition
- Automatic Melt Cycle
- Boil-out Temperature Control
- Legs (non-filter models)
- Rack-type Basket Support
- Basket Hanger
- Twin Baskets
- Casters (filter models only)

FRYMASTER GAS LINE INFORMATION

Fryers must be installed with proper size gas line. Each single unit requires a 3/4" NPT connection; battered units (2-3) require one 1" NPT connection; battered units (4) require two 1" NPT connections.

FRYMASTER H55 HIGH EFFICIENCY H55 GAS FRYERS

PART #	DESCRIPTION	PRICE
FRYER ACCESSORIES		
8030099	Basket, Full Size — 12-3/8 x 12-7/8 x 5-1/4 (Can't Be Used w/ Basket Lifts)	\$585
8030357	Basket, Triplet — 4-1/2 x 13-1/4 x 6	\$400
8030271	Basket, Twin Size — 5 5-7/8 x 12-5/8 x 6-5/8	\$400
8030132	Basket Support Rack, Full Pot 12-1/2 W x 13-3/4 D	\$280
8030133	Basket Support Rack, Split Pot — 6 W x 14 D	\$250
8030136	Basket Support Screen, Full Pot 12-1/2 W x 13-3/4 D	\$340
8030429	Brush, L-Shaped Tampico 21" L x 2" Diameter	\$195
	Casters — Set of Four	\$650
8230619	Chicken/Fish Tray, Full Pot — 12-3/8 W x 14 D (Not Available For Split Pot)	\$735
8030197	Clean-Out Rod — 27" Long	\$250
8239426	Cover, Stainless Steel, Full Pot 15-1/8 W x 20-1/4 D	\$565
8239416	Covers, Split Pot	\$340
2109291	Top Connecting Strip	\$350
8233938	Crumb Scoop — 1-1/4 W x 6-1/2 D x 22-3/4 H	\$280
8030059	Fish Scoop 8-1/8 W x 8-1/2 D w/ 17-3/8 Handle	\$290
8030446	Fish Skimmer — No Hooks 6" Square w/ Insulated Handle	\$280
9103557	Flue Deflector — 12-1/2 W x 6-7/8 H	\$300
	Foam Deck Basket Banger*	\$455/ FRYPOT
	Legs — 8-1/2" H, Set of Four (Non-Filter Models Only)	\$650
8061698	Quick Disconnect Hose 1" Gas Line, 36" Long	\$1,255
8061699	Quick Disconnect Hose 1" Gas Line, 48" Long	\$1,345
8061701	Quick Disconnect Hose 3/4" Gas Line, 36" Long	\$1,015
8061700	Quick Disconnect Hose — 3/4" Gas Line, 48" Long	\$1,105
8030103	Sediment Tray, Full Pot — 12-1/2 x 14 x 6-1/2	\$955
(L) 8030107L (R) 8030108R	Sediment Tray, Split Pot — 5-7/8 x 14 x 6-1/2	\$725
8236559	Splash Shield — 20 D x 6-1/4 H	\$565

*If ordered after fryer purchase, requires changing top connecting strip(s).

DESCRIPTION	PRICE
EXTERNAL OIL DISCHARGE OPTIONS	

External oil discharge — available on built-in filter batteries of 2 or more frypots or a frypot and spreader. Must specify front or rear connection. Front connection comes with 5ft. washdown hose.

FRONT \$2,730

REAR \$2,090

SPREADERS — ADD TO PRICE OF FRYER(S)	
Spreader Cabinet — Call Customer Service for availability and placement.	\$2,405

PART #	DESCRIPTION	PRICE
FILTERING ACCESSORIES		
8030002	Filter Powder (80, 1oz. Packs)	\$245
8030170	Filter Paper (19-1/2 x 27-1/2) Box of 100 sheets	\$290

NOTES:

- Call Customer Service or refer to manual provided with fryer for correct sizing information including high elevation installations.
- If elevation is between 5,000 — 10,000 feet, specify the elevation level. Fryer may not perform at optimum levels above this elevation.
- DO NOT CURB MOUNT.
- Any questions or pricing information other than the above should be referred to Customer Service .

Frymaster®

MJ Fryers (MJ40, MJ50 and MJCF)

World-Recognized Master of Open-Pot Frying



MJ40 fryer shown with optional digital controller and casters



MJ50 battery shown with millivolt controller and casters



MJCF fryer with optional electronic timer controller and casters

- 1. Offer an open-pot gas line-up unmatched in the industry.** Model offerings provide 40, 50, and 80-lb. oil capacity options with and without electrical hook-up. Respective fry areas are 12" x 15", 14" x 15", and 18" x 19". Respective Btu/hr inputs are 104,000, 122,000, and 150,000.
- 2. Have models that can handle the breadth of menu items** from French fries to breaded fish to bone-in chicken.
- 3. Are named for their signature Master Jet burner** technology that has earned a legendary reputation for durability and reliability. MJ burners require no burner cleaning or air shutter adjustment.
- 4. Are easy to clean.** Open-pot design allows safe access to every inch of the frypot.
- 5. Are simple to operate.** Just set the desired frying temperature and start cooking.
- 6. Automatically shut off the fryer** if temperature exceeds the high-limit.
- 7. Collect and aid sediment removal** with a deep collection zone and large 1-1/4" IPS ball-type drain valve

MJ Fryers are unsurpassed in their versatility, proven worldwide performance, and low maintenance needs.

FRYMASTER PERFORMANCE MJ40 GAS FRYERS

MJ40 FRYERS — Without filtration, with stainless steel frypot, door(s) and sides.

MODEL	MILLIVOLT CONTROLLER	OIL CAPACITY LBS.	COOK AREA W" X L" X D"	BTU/HR INPUT	SHIPPING WEIGHT LBS.
MJ140	\$4,760	40	12 x 15 x 4-1/4	110,000	185
MJ240	\$9,365	(2) 40	(2) 12 x 15 x 4-1/4	(2) 110,000	370
MJ340	\$13,540	(3) 40	(3) 12 x 15 x 4-1/4	(3) 110,000	555

STANDARD ACCESSORIES

- Rack-type Basket Support
- Basket Hanger
- Covers
- EZSpark Ignitor
- Flue Deflector
- Full set of Legs & Casters
- Twin Baskets

PART #	DESCRIPTION	PRICE
--------	-------------	-------

FRYER ACCESSORIES

8030015	Basket, Full Size — 11-3/4 x 14 x 4-5/8	\$585
8030271	Basket, Twin Size — S 5-7/8 x 12-5/8 x 6-5/8	\$400
8030032	Basket Support Rack, Full Pot 11-1/2 W x 14-5/8 D	\$280
8030037	Basket Support Screen, Full Pot 11-1/2 W x 14-5/8 D	\$330
8030429	Brush, L-Shaped Tampico 21" L x 2" Diameter	\$195
8233048	Chicken/Fish Plate, Full Pot 11-3/4 W x 14-3/4 H	\$705
8030197	Clean-Out Rod — 27" Long	\$250
8239426	Cover, Stainless Steel, Full Pot 15-1/8 W x 20-1/4 D	\$565
8233938	Crumb Scoop — 1 1/4W x 6 1/2D x 22 3/4L	\$280
2109291	Top Connecting Strip	\$350
8030059	Fish Scoop 8-1/8 W x 8-1/2 D w/ 17-3/8 Handle	\$290
8030446	Fish Skimmer — No Hooks 6" Square w/ Insulated Handle	\$280
9103557	Flue Deflector — 12-1/2 W x 6-7/8 H	\$300
	Legs — 6" H, Set of Four, Adjustable Stainless Steel	\$650
8061698	Quick Disconnect Hose 1" Gas Line, 36" Long	\$1,255
8061699	Quick Disconnect Hose 1" Gas Line, 48" Long	\$1,345

FRYMASTER GAS LINE INFORMATION

Fryers must be installed with proper size gas line. Each single unit requires a 3/4" npt connection; battered units require one 1" NPT connection.

PART #	DESCRIPTION	PRICE
--------	-------------	-------

FRYER ACCESSORIES (CONT.)

8061701	Quick Disconnect Hose 3/4" Gas Line, 36" Long	\$1,015
8061700	Quick Disconnect Hose — 3/4" Gas Line, 48" Long	\$1,105
8030188	Sediment Tray, Full Pot 11-1/4 x 14-1/2 x 4-1/8	\$790
8236559	Splash Shield — 20 D x 6-1/4 H	\$565

DESCRIPTION	PRICE
-------------	-------

SPREADERS — ADD TO PRICE OF FRYER(S)

Spreader Cabinet — Call Customer Service for availability and placement.	\$2,405
Center Spreader — ADD	\$2,615

NOTES:

- Call Customer Service or refer to manual provided with fryer for correct sizing information including high elevation installations.
- If elevation is between 2,000 — 6,000 feet, specify the elevation level. Not available above 6,000 feet.
- DO NOT CURB MOUNT.
- Any questions or pricing information other than the above should be referred to Customer Service .

FRYMASTER PERFORMANCE MJ50 GAS FRYERS

MJ50 FRYERS — Without filtration, with stainless steel frypot, door(s) and sides.

MODEL	MILLIVOLT CONTROLLER	OIL CAPACITY LBS.	COOK AREA W" X L" X D"	BTU/HR INPUT	SHIPPING WEIGHT LBS.
MJ150	\$7,290	50	14 x 15 x 5	122,000	202
MJ250	\$14,375	(2) 50	(2) 14 x 15 x 5	(2) 122,000	404
MJ350	\$21,495	(3) 50	(3) 14 x 15 x 5	(3) 122,000	606

STANDARD ACCESSORIES

- Rack-type Basket Support
- Basket Hanger
- Covers
- EZSpark Ignitor
- Flue Deflector
- Full set of Legs & Casters (MJ150)
- Casters on all batteries
- Twin Baskets

PART #	DESCRIPTION	PRICE
--------	-------------	-------

FRYER ACCESSORIES

8030099	Basket, Full Size — 12-3/8 x 12-7/8 x 5-1/4 (Can't Be Used w/ Basket Lifts)	\$585
8030357	Basket, Triplet Size — 4-1/2 x 13-1/4 x 6	\$400
8030271	Basket, Twin Size — 5-7/8 x 12-5/8 x 6-5/8	\$400
8030132	Basket Support Rack, Full Pot 12-1/2 W x 13-3/4 D	\$280
8030136	Basket Support Screen, Full Pot 12-1/2 W x 13-3/4 D	\$340
8030429	Brush, L-Shaped Tampico 21" L x 2" Diameter	\$195
8230619	Chicken/Fish Tray, Full Pot — 12-3/8 W x 14 D (Not Available For Split Pot)	\$735
8030197	Clean-Out Rod — 27" Long	\$250
8239426	Cover, Stainless Steel, Full Pot 15-1/8 W x 20-1/4 D	\$565
2109291	Top Connecting Strip	\$350
8233938	Crumb Scoop — 1 1/4 W x 6 1/2 D x 22 3/4 L	\$280
8030059	Fish Scoop 8-1/8 W x 8-1/2 D w/ 17-3/8 Handle	\$290
8030446	Fish Skimmer — No Hooks 6" Square w/ Insulated Handle	\$280
9103557	Flue Deflector — 12-1/2 W x 6-7/8 H	\$300
	Legs — 6" H, Set of Four, Adjustable Stainless Steel	\$650
8061698	Quick Disconnect Hose 1" Gas Line, 36" Long	\$1,255
8061699	Quick Disconnect Hose 1" Gas Line, 48" Long	\$1,345
8061701	Quick Disconnect Hose 3/4" Gas Line, 36" Long	\$1,015
8061700	Quick Disconnect Hose — 3/4" Gas Line, 48" Long	\$1,105
8030103	Sediment Tray, Full Pot — 12-1/2 x 14 x 6-1/2	\$955
8236559	Splash Shield — 20 D x 6-1/4 H	\$565

FRYMASTER GAS LINE INFORMATION

Fryers must be installed with proper size gas line. Each single unit requires a 3/4" NPT connection; battered units (2-3) require one 1" NPT connection

DESCRIPTION	PRICE
-------------	-------

SPREADERS — ADD TO PRICE OF FRYER BATTERY

Spreader Cabinet — Call Customer Service for availability and placement.	\$2,405
Center Spreader — ADD	\$2,615

NOTES:

- Call Customer Service or refer to manual provided with fryer for correct sizing information including high elevation installations.
- If elevation is between 2,000 — 6,000 feet, specify the elevation level. Not available above 6,000 feet.
- DO NOT CURB MOUNT.
- Any questions or pricing information other than the above should be referred to Customer Service.

FRYMASTER PERFORMANCE MJCF GAS FRYERS

MJCF FRYER — Without filtration, stainless steel frypot, door and sides.

MODEL	MILLIVOLT CONTROLLER	OIL CAPACITY LBS.	COOK AREA W" X L" X D"	BTU/HR INPUT	SHIPPING WEIGHT LBS.
MJ1CF	\$8,415	80	18 x 19 x 4-1/2	150,000	297

NOTES: MJCF fryer does not have basket lift option.

STANDARD ACCESSORIES

- Legs
- Rack-type Basket Support
- Basket Hanger
- Twin Baskets

PART #	DESCRIPTION	PRICE
--------	-------------	-------

FRYER ACCESSORIES

8030017	Basket, Full Size, HD60G — 17-1/2 x 16-3/4 x 6	\$610
8030023	Basket, Triplet Size — 5-3/4 x 17-1/8 x 6-1/8	\$455
8030024	Basket, Twin Size — 8-3/4 x 16-3/4 x 6	\$545
8030137	Basket Support Rack, Full Pot 17-1/2 W x 17-1/2 D	\$280
8030138	Basket Support Screen, Full Pot 17-1/2 W x 18-1/2 D	\$340
8030429	Brush, L-Shaped Tampico 21" L x 2" Diameter	\$195
	Casters — Set of Four	\$650
8230368	Chicken/Fish Tray, Full Pot 17-7/8 W x 18-5/8 D	\$905
8030197	Clean-Out Rod — 27" Long	\$250
8239413	Cover, Stainless Steel, Full Pot 20-3/8 W x 28 D	\$565
8233938	Crumb Scoop 1-1/4" W x 6-1/2" D x 22-3/4" long	\$280
8030446	Fish Skimmer, No Hooks 6" Square w/ Insulated Handle	\$280
9103185	Flue Deflector — 14-1/2 W 8 D	\$300
	Legs — 6" H, Set of Four, Adjustable Nickel	\$490
	Legs — 6" H, Set of Four, Adjustable Stainless Steel	\$650
8061701	Quick Disconnect Hose 3/4" Gas Line, 36" Long	\$1,015
8061700	Quick Disconnect Hose — 3/4" Gas Line, 48" Long	\$1,105
8030187	Sediment Tray, Full Pot 17-1/2 W x 18-1/2 D x 4-3/8 H	\$950
8235978	Splash Shield — 20 D x 6-1/4 H	\$565
9102662	Top Connecting Strip 2-1/8 W x 28-1/8 D x 1-3/4 H	\$405
8030059	Fish Scoop 8-1/8 W x 8-1/2 D w/ 17-3/8 Handle	\$290

FRYMASTER GAS LINE INFORMATION

Fryers must be installed with proper size gas line.
Each single unit requires a 3/4" NPT connection

DESCRIPTION	PRICE
-------------	-------

SPREADERS - ADD TO PRICE OF FRYER(S)

Spreader Cabinet (free standing only)	\$3,185
---------------------------------------	---------

NOTES:

- If elevation is between 2,000 - 6,000 feet, specify the elevation level. Fryer may not perform at optimum levels above this elevation.
- **DO NOT CURB MOUNT.**
- Any questions or pricing information other than the above should be referred to **Customer Service**.

Frymaster®

GF Fryers

Deliver Outstanding Open-Port Frying Performance

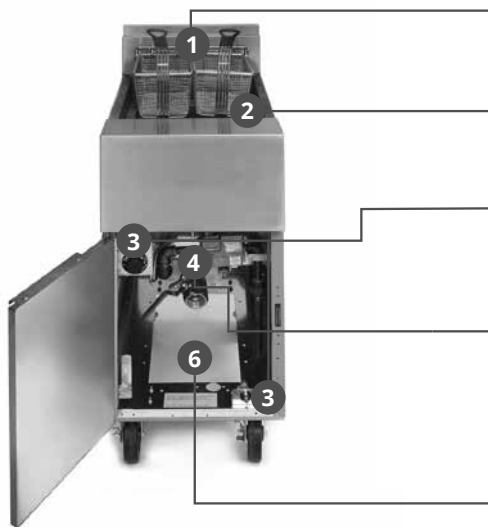

1. Are designed for versatile frying production. Model offerings provide 40 and 50-lb. oil capacity options.

2. Are easy to clean. Open-pot design allows safe access to every inch of the frypot.

3. Are simple to operate. Just set the desired frying temperature and start cooking.

4. Automatically shut off the fryer if temperature exceeds the high-limit.

5. Require no electrical hookup.

6. Have a durable heat transfer system that can be counted on for years of reliable performance.

GF14 fryer shown with optional



7. Have durable accessories that support frying operation including the frypot covers, full size baskets, basket support screen, and casters.

8. Collect and aid sediment removal with a deep collection zone and large 1-1/4" IPS ball-type drain valve.

GF Fryers offer all the benefits of open-pot frying at an entry level price.

GF40

FRYMASTER STANDARD GF GAS FRYERS - GF SERIES

GF FRYERS — with stainless steel frypot and door, and aluminized sides.

MODEL	MILLIVOLT CONTROLLER	OIL CAPACITY LBS.	COOK AREA W" X L" X D"	BTU/HR INPUT	SHIPPING WEIGHT LBS.
GF14	\$2,815	40	12 x 15 x 4	100,000	152
GF40	\$6,200	50	14 x 15 x 5	122,000	176

NOTES: GF14 and GF40 fryers do not have basket lift, built-in filtration, battery options or split pots.

STANDARD ACCESSORIES

- Full Set Legs and Casters
- Rack-type Basket Support
- Basket Hanger
- Flue Deflector
- Twin Baskets

PART #	DESCRIPTION	PRICE
--------	-------------	-------

FRYER ACCESSORIES

8030099	Basket, Full Size, GF 40 12-3/8 x 12-7/8 x 5-1/4 (Can't Be Used w/ Basket Lifts)	\$585
8030015	Basket, Full Size, GF14 — 11-3/4 x 14 x 4-5/8	\$585
8030357	Basket, Triple, GF 40 — 4-1/2 x 13-1/4 x 6	\$400
8030271	Basket, Twin Size — 5-7/8 x 12-5/8 x 6-5/8	\$400
8030132	Basket Support Rack, Full Pot, GF 40 12-1/2 W x 13-3/4 D	\$280
8030032	Basket Support Rack, Full Pot, GF14 11-1/2 W x 14-5/8 D	\$280
8030136	Basket Support Screen, Full Pot, GF 40 12-1/2 W x 13-3/4 D	\$340
8030037	Basket Support Screen, Full Pot, GF14 11-1/2 W x 14-5/8 D	\$330
8030429	Brush, L-Shaped Tampico 21" L x 2" Diameter	\$195
8230619	Chicken/Fish Tray, Full Pot, GF40 12-3/8 W x 14 D	\$735
8233048	Chicken/Fish Plate, Full Pot, GF14 11-3/4 W x 14-3/4 H	\$705
8236559	Splash Shield — 20 D x 6-1/4 H	\$565
8030197	Clean-Out Rod — 27" Long	\$250
8239426	Cover, Stainless Steel, Full Pot 15-1/8 W x 20-1/4 D	\$565
8030059	Fish Scoop 8-1/8 W x 8-1/2 D w/ 17-3/8 Handle	\$290
8030446	Fish Skimmer, No Hooks 6" Square w/ Insulated Handle	\$280
9103557	Flue Deflector, GF14 & G40 12-1/2 W x 6-7/8 H	\$300
8061701	Quick Disconnect Hose 3/4" Gas Line, 36" Long	\$1,015
8061700	Quick Disconnect Hose — 3/4" Gas Line, 48" Long	\$1,105
8030103	Sediment Tray, Full Pot, GF40 12-1/2 x 14 x 6-1/2	\$955
8030188	Sediment Tray, Full Pot, GF14 11-1/4 x 14-1/2 x 4-1/8	\$790
9102285	Top Connecting Strip, G14, GF40 2-1/8 W x 20-5/8 D x 1-3/4 H	\$350

FRYMASTER GAS LINE INFORMATION

Fryers must be installed with proper size gas line.
Each single unit requires a 3/4" NPT connection.

NOTES:

- If elevation is between 2,000 - 6,000 feet, specify the elevation level.
Fryer may not perform at optimum levels above this elevation.
- **DO NOT CURB MOUNT.**
- Any questions or pricing information other than the above should be referred to **Customer Service**.

FilterQuick® with FQ4000 easyTouch® Controller Automatic Filtration and Optional Oil Quality Sensor

Electric Fryers

Fingertip Filtration Plus:

40% Less Oil, 10% Less Energy, Outstanding Results

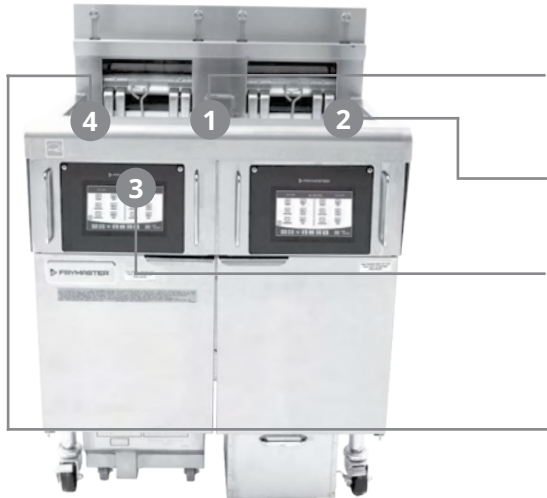

- 30-lb or 60-lb open frypot design** requires 40% less oil and ensures quick and easy cleaning. Saves money, time and labor.
- Independent frypot construction** allows convenient frypot repairs in the field, if needed.
- FQ4000 easyTouch® Controller** has operation management features that monitor and help control food quality, oil life, and equipment performance. Offers configurable and customizable recipe management, and connectivity compatible.
- Safe, self-standing heating elements** ensure industry leading energy efficiency and sealed rotation housing protects against oil migration.



- Fingertip, closed cabinet, fully-automatic filtration** starts with easy touch operating actions.
 - Safe technology ensures only one frypot can drain at a time. Filtration is as easy as pushing a button.
 - The filter pump agitates the oil in the frypot before draining to lift the crumbs from the bottom of the frypot, aiding their removal.
 - The frypot begins heating as soon as a safe level of oil returns to the frypot to speed return to set temperature.
 - The pump is protected by a pressure relief valve for bulk oil systems.



- Optional Oil Quality Sensor (OQS)** monitors the oil's health and advises when to discard. No more guesswork.
- Innovative safety features** offer proprietary advantages over other fryers that prevent simultaneous vat filtrations.
- Automatic Top-Off (ATO) feature** senses the oil level and adds oil as needed from an in-cabinet supply.



FilterQuick fryers exceed ENERGY STAR® guidelines for high efficiency and are part of the Welbilt EnerLogic® program.

FRYMASTER OIL-CONSERVING FILTERQUICK 30 SERIES II ELECTRIC FRYERS WITH FULLY-AUTOMATIC FILTRATION

FILTERQUICK 30 FRYER BATTERIES — With filtration, FQ4000 easyTouch controller, auto top-off, stainless steel frypots, doors and sides.

MODEL	FQ4000 CONTROLLER*	OIL CAPACITY LBS.	COOK AREA W" X L" X D"	ELECTRICAL INPUT	SHIPPING WEIGHT LBS.
2FQE30U	\$44,745	(2) 30	(2) 13 x 14 x 3-3/4	14 kw	535
3FQE30U	\$59,740	(3) 30	(3) 13 x 14 x 3-3/4	14 kw	667
4FQE30U	\$75,290	(4) 30	(4) 13 x 14 x 3-3/4	14 kw	875

*Standard with FilterQuick FQ4000 easyTouch controller. NOTES: Basket Lifts - Add \$4,820 for each frypot. | Casters included in pricing.

POWER REQUIREMENTS, PER FRYPOT - BASIC DOMESTIC

MODELS	KW	ELEMENTS/FRYPOT			CONTROLS/FRYPOT	FILTER	AUTO TOP-OFF/FRYPOT	BASKET LIFTS/FRYPOT
		VOLTAGE	3 PHASE*	1 PHASE**				
FQE30U	14	208v	39 A	67 A	1A	5A	1A	2A
		240v	34 A	58 A	1A	4A	1A	2A
		480v	17 A	N/A	120v 1 A	120v 8 A	1A	120v 3 A

*3PH / 3 wire / plus ground wire **1PH / 2 wire / plus ground wire

STANDARD ACCESSORIES

- FilterQuick Filtration with ATO
- Casters
- Rack-type Basket Support
- Bulk Oil (disposal and fresh fill)
- Bottom Splash Shield
- Cords
- Cover
- Basket Hanger
- Twin Baskets
- Filter Starter Kit
- Oil Management Package*
- 4GPM Pump
- Jug in Box (JIB) Holder

*Oil Management Package included at no extra charge.

PART #	DESCRIPTION	PRICE
FRYER ACCESSORIES		
8030099	Basket, Full Size — 12-3/8 x 12-7/8 x 5-1/4 (Can't Be Used w/ Basket Lifts)	\$585
8030438	Basket, Triplet — 4-1/4 x 13-1/4 x 5-1/2	\$400
8030271	Basket, Twin Size — 5-5/8 x 12-5/8 x 6-5/8	\$400
8030132	Basket Support Rack, Full Pot 12-1/2 W x 13-3/4 D	\$280
8030429	Brush, L-Shaped Tampico 21" L x 2" Diameter	\$195
8030278	Brush, L-Shaped Teflon — 26-3/4" L x 1" Diameter	\$245
8238224	Splash Shield, Side — 19-1/2 W x 11-3/4 H	\$565
8238861	Chicken/Fish Tray, Full Pot 13 W x 13-1/2 D x 11 H (Not Available for Split Pot)	\$725
8030388	Clean-Out Rod — 26" Long	\$250
8238899	Cover, Stainless Steel, Full Pot 14-3/8 W x 19-1/2 D	\$565
8238065	Fish Plate — 13" x 13-1/2" x 4-1/2"	\$725
8030059	Fish Scoop 8-1/8 W x 8-1/2 D w/ 17-3/8 Handle	\$290
8030446	Fish Skimmer — No Hooks 6" Square w/ Insulated Handle	\$280

NOTES:

- One cord is provided per frypot on 3 phase models.
- Plug is an optional accessory on units shipping with cord, except 480V 3 phase units — no plug is available. EXCEPTION: Units shipping to Canada with a cord must have a plug as well.
- Optional plug — (Domestic: NEMA #15-60P) — Add \$250 for each frypot.

DESCRIPTION	PRICE
SPECIAL OIL OPTIONS	
Semi-Solid / Solid Shortening* Call Customer Service before ordering	\$4,330
Front Oil Discharge (Precludes bulk rear oil discharge)	SPECIFY WHEN ORDERED
Oil Quality Sensor* MUST call customer service before ordering	\$3,910

*Must be requested at time of fryer order.

SPREADERS — ADD TO PRICE OF FRYER(S)

Spreader Cabinet — Call Customer Service for availability and placement. **\$2,405**

PART #	DESCRIPTION	PRICE
FILTERING ACCESSORIES		
8030002	Filter Powder (80, 1oz. Packs)	\$245
8030445	Filter Paper (16-1/2 x 25-1/2) Box Of 100 Sheets	\$290

NOTES (cont.):

- Single phase units must be field wired. No cord or plug provided. Check electrical codes for proper supply line sizing.
- Controller, filter pump and basket lifts are powered by element voltages except 480V fryers.
- All 480 volt models are provided with separate 120 volt cord and plug for filter pump, controller, and/or basket lifts.
- 480V 3 PH option — Call customer service for price.
- No plug or cord is provided on single phase fryers.
- Any questions or pricing information other than the above should be referred to **Customer Service**.

FRYMASTER OIL-CONSERVING FILTERQUICK 60 SERIES I ELECTRIC FRYERS WITH FULLY-AUTOMATIC FILTRATION

FILTERQUICK 60 FRYER BATTERIES — With filtration, FQ4000 easyTouch controller, auto top-off, stainless steel frypots, door(s) and sides.

MODEL	FQ4000 CONTROLLER*	OIL CAPACITY LBS.	COOK AREA W" X L" X D"	ELECTRICAL INPUT	SHIPPING WEIGHT LBS.
1FQE60U	\$37,035	(1) 60	(1) 18 x 14 x 3-3/4	(1) 17 kw	390
2FQE60U	\$54,645	(2) 60	(2) 18 x 14 x 3-3/4	(2) 17 kw	585
3FQE60U	\$71,335	(3) 60	(3) 18 x 14 x 3-3/4	(3) 17 kw	815

*Standard with FilterQuick FQ4000 easyTouch controller. NOTES: Casters included in pricing.

STANDARD ACCESSORIES

- Rack-type Basket Support
 - Basket Hangers
 - Twin Baskets
 - 8GPM Pump
- Filter models have:
- Filter Starter Kit
 - Drain Safety Switch
 - Casters

PART #	DESCRIPTION	PRICE
--------	-------------	-------

FRYER ACCESSORIES

8030271	Basket, Twin Size — S 5-7/8 x 12-5/8 x 6-5/8	\$400
8030441	Basket, Chicken — 17-3/4 x 12-3/4 x 11	\$990
8030437	Basket, Dual — 8 x 12-5/8 x 7	\$420
8030435	Basket, Full Size — 17-1/2 x 12-7/8 x 6-1/8	\$570
8030357	Basket, Triplet — 4-1/2 x 13-1/4 x 6	\$400
8030099	Basket, Full Size — 12-3/8 x 12-7/8 x 5-1/4 (Can't Be Used w/ Basket Lifts)	\$585
8030380	Basket Support Rack Full Pot 13-5/8 W x 18 D	\$280
8030429	Brush, L-Shaped Tampico 21" L x 2" Diameter	\$195
8030278	Brush, L-Shaped Teflon 26-3/4" L x 1" Diameter	\$245
2208962	Chicken/Fish Plate, 11814E — 17 W x 13-1/2 D	\$725
8030197	Clean-Out Rod — 27" Long	\$250
1069620	Frypot Cover, Full Pot — 19 W x 19-3/8 D Stainless Steel	\$565
8030059	Fish Scoop 8-1/8 W x 8-1/2 D w/ 17-3/8 Handle	\$290
8030446	Fish Skimmer, No Hooks 6" Square w/ Insulated Handle	\$280
1086187	Sediment Tray — 17-3/4 x 13-5/8 x 11	\$1,160
8238155	Splash Shield, 1814E — 20-5/8 D x 6 H	\$565
8238190	Top Connecting Strip — 2-3/4 W x 21 D	\$350

NOTES:

- One cord is provided per frypot.
- Plug is an optional accessory on units shipping with cord, except 480V 3 phase units — no plug is available. EXCEPTION: Units shipping to Canada with a cord must have a plug as well.
- Optional plug — (Domestic: NEMA #15-60P) — Add \$250 for each frypot.
- Controller, filter pump and basket lifts are powered by element voltages except 480V fryers.
- All 480 volt models are provided with separate 120V cord and plug for filter pump, controller and/or basket lifts.
- 480V 3PH option — Call customer service for price, per full or dual split frypot.
- No plug or cord is provided on single phase fryers.
- Any questions or pricing information other than the above should be referred to **Customer Service**.

POWER REQUIREMENTS, PER FRYPOT - BASIC DOMESTIC

MODELS	KW	ELEMENTS/FRYPOT		CONTROLS /FRYPOT	FILTER
		VOLTAGE	3 PHASE*		
1FQE60U	17	208v	48 A	1A	5A
2FQE60U	17	240v	41 A	1A	4A
3FQE60U	17	480v	21 A	120v 1 A	120v 8 A

*3PH / 3 wire / plus ground wire

DESCRIPTION	PRICE
-------------	-------

SPECIAL OIL OPTIONS

External oil discharge — available on built-in filter batteries of 2 or more frypots or a frypot and spreader. Must specify front or rear connection. Front connection comes with 5ft. washdown hose.	FRONT \$2,730
	REAR \$2,090
Bulk oil (dispose and fresh fill) on batteries with built-in filtration*	\$4,305
Auto Topoff with side saddle* (requires additional 3" space)	\$4,460
Auto Topoff with external 6 foot hose* (no side saddle)	\$2,870
Oil Quality Sensor* MUST call customer service before ordering	\$3,910

*Must be requested at time of order.

PART #	DESCRIPTION	PRICE
--------	-------------	-------

FILTERING ACCESSORIES

8030002	Filter Powder (80, 1oz. Packs)	\$245
8030289	Filter Paper (22 x 34) Box Of 100 Sheets	\$470
8239116	Filter Screen (High Sediment) 8-1/4 W x 14 D, 2 Required	\$675/ EACH

Frymaster®

1814 High-Production, Oil-Conserving, Electric Fryers

Conserve Oil, Energy, & Space



Model Shown: 1814E/RE17/1814E

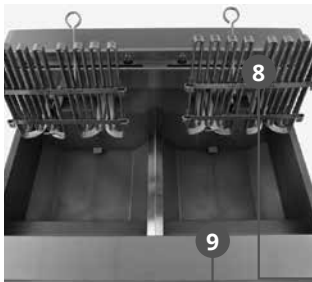

1. **Use 10-15% less hood and floor space** than standard fryer systems.
2. **Use upwards of 30% less energy** than comparable standard fryer systems.
3. **Use less oil** reducing operating costs and environmental impact.
 - **20% less** than 3 standard 50-lb fryers (120 lbs of oil vs 150 lbs)
 - **15% less** than 4 standard 50-lb fryers (170 lbs of oil vs 200 lbs)
4. **Deliver flexible, high-production cooking** with one or two 18" x 14" x 4-1/4" cooking area(s) that can cook three baskets of food at the same time. Each 18" x 14" x 4-1/4" frypot can produce:
 - **112 lbs.** of frozen chicken nuggets/hr
 - **84 lbs.** of French fries/hr
 - **66 lbs.** of fresh-breaded chicken strips/hr
 - **66 lbs.** of dry dredge catfish/hr
 - **96 pieces** of fresh-breaded, 8-piece cut chicken/hr
 - **67 lbs.** of wings/hr (756 pieces)
5. **Control food and oil quality with the SMART4U® 3000 controller**, which has programmable cook buttons and features that make it easy to produce consistent, great-tasting food. Digital and CM3.5 controller options are also available.
6. **Save on equipment costs.**
 - Two 1814E fryers do the work of three 50-lb fryers.
 - Two 1814E & one RE17 do the work of four 50-lb fryers.
7. **Support oil station management** with built-in filtration options, making it easy to preserve oil life and ensure consistent, great-tasting food. 8 GPM pump quickly removes crumbs and sediment, making the filter process quick and effective.
8. **Optimize heat transfer** with robust, self-standing, ribbon-type, low-watt density electric elements.
9. **Handle high-sediment foods with ease.** Sloping bottom ensures fast drainage and easy cleaning.



1814E models meet ENERGY STAR® guidelines.
All 1814 fryers are part of the ManitowocEnerLogic™ energy program.

FRYMASTER HIGH-PRODUCTION OIL-CONSERVING 1814 ELECTRIC FRYERS

11814E FRYER — Without filtration, stainless steel frypot, door and sides.

MODEL	DIGITAL TIMER CONTROLLER	CM 3.5 CONTROLLER	LANE CONTROLLER*	OIL CAPACITY LBS.	COOK AREA W" X L" X D"	ELECTRICAL INPUT	SHIPPING WEIGHT LBS.
11814E	\$12,630	\$14,505	\$16,010	60	18 x 14 x 4-1/4	17 kw	255

*Standard with Lane Controller. 3000 and 3010 controller can be substituted for Lane controller at no cost.

11814E FRYERS — With filtration, stainless steel frypots, door(s) and sides.

MODEL	DIGITAL TIMER CONTROLLER	CM 3.5 CONTROLLER	LANE CONTROLLER*	OIL CAPACITY LBS.	COOK AREA W" X L" X D"	ELECTRICAL INPUT	SHIPPING WEIGHT LBS.
11814EF	\$28,060	\$29,945	\$31,455	(1) 60	(1) 18 x 14 x 4-1/4	(1) 17 kw	390
21814EF	\$42,300	\$46,060	\$49,080	(2) 60	(2) 18 x 14 x 4-1/4	(2) 17 kw	585
31814EF	\$55,775	\$61,320	\$65,770	(3) 60	(3) 18 x 14 x 4-1/4	(3) 17 kw	815

*Standard with Lane Controller. 3000 and 3010 controller can be substituted for Lane controller at no cost.

STANDARD ACCESSORIES

- Rack-type Basket Support
 - Basket Hangers
 - Twin Baskets
 - Legs (non-filter models)
- Filter models have:
- Filter Starter Kit
 - Drain Safety Switch
 - Casters
 - 8GPM Pump

NOTES:

- Add **\$4,915** /frypot for basket lifts.

PART #	DESCRIPTION	PRICE
--------	-------------	-------

FRYER ACCESSORIES

8030271	Basket, Twin Size — 5 5-7/8 x 12-5/8 x 6-5/8	\$400
8030441	Basket, Chicken — 17-3/4 x 12-3/4 x 11	\$990
8030437	Basket, Dual — 8 x 12-5/8 x 7	\$420
8030435	Basket, Full Size — 17-1/2 x 12-7/8 x 6-1/8	\$570
8030380	Basket Support Rack Full Pot, 1FQG60 13-5/8 W x 18 D	\$280
8030429	Brush, L-Shaped Tampico 21" L x 2" Diameter	\$195
8030278	Brush, L-Shaped Teflon — 26-3/4" L x 1" Diameter	\$245
8239402	Cover, Stainless Steel, Full Pot, Basket Lifts 19 W x 19-3/8 D	\$565
2208962	Chicken/Fish Plate, 11814E — 17 W x 13-1/2 D	\$725
8030197	Clean-Out Rod — 27" Long	\$250
8030059	Fish Scoop 8-1/8 W x 8-1/2 D w/ 17-3/8 Handle	\$290
8030446	Fish Skimmer, No Hooks 6" Square w/ Insulated Handle	\$280
1086187	Sediment Tray — 17-3/4 x 13-5/8 x 11	\$1,160
8238155	Splash Shield, 1814E — 20-5/8 D x 6 H	\$565
8238190	Top Connecting Strip — 2-3/4 W x 21 D	\$350

NOTES:

- One cord is provided per frypot.
- Plug is an optional accessory on units shipping with cord, except 480V 3 phase units — no plug is available.
EXCEPTION: Units shipping to Canada with a cord must have a plug as well.
- Optional plug — (Domestic: NEMA #15-60P) — Add **\$250** for each frypot.
- Controller, filter pump and basket lifts are powered by element voltages except 480V fryers.

POWER REQUIREMENTS, PER FRYPOT – BASIC DOMESTIC

MODELS	KW	ELEMENTS/FRYPOT	CONTROLS /FRYPOT	FILTER
		VOLTAGE	3 PHASE*	
11814E	17	208v	48 A	1A 5A
21814E	17	240v	41 A	1A 4A
31814E	17	480v	21 A	120v 1 A 120v 8 A

*3PH / 3 wire / plus ground wire

DESCRIPTION	PRICE
-------------	-------

SPECIAL OIL OPTIONS

External oil discharge — available on built-in filter batteries of 2 or more frypots or a frypot and spreader. Must specify front or rear connection. Front connection comes with 5ft. washdown hose.	FRONT \$2,730
	REAR \$2,090
Bulk oil (dispose and fresh fill) on batteries* with built-in filtration	\$4,305

*Must be requested at time of order.

SPREADERS — ADD TO PRICE OF FRYER(S)

Spreader Cabinet — Call Customer Service for availability and placement.	\$3,185
--	----------------

PART #	DESCRIPTION	PRICE
--------	-------------	-------

FILTERING ACCESSORIES

8030002	Filter Powder (80, 1oz. Packs)	\$245
8030289	Filter Paper (22 x 34) Box Of 100 Sheets	\$470
8239116	Filter Screen (High Sediment) 8-1/4 W x 14 D, 2 Required	\$675/ EACH

- All 480 volt models are provided with separate 120V cord and plug for filter pump, controller and/or basket lifts.
- 480V 3PH option — Call customer service for price, per full or dual split frypot.
- No plug or cord is provided on single phase fryers.
- Any questions or pricing information other than the above should be referred to **Customer Service**.

Frymaster®

OCF30™

40% Less Oil, 10% Less Energy,
Outstanding Results

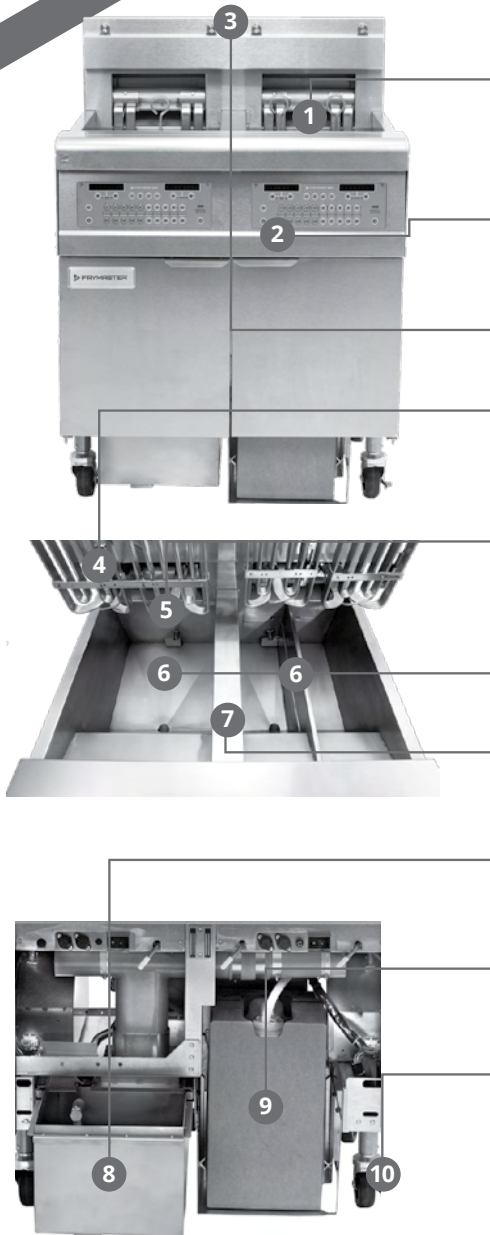

1. **30-lb open frypot design** requires 40% less oil and ensures quick and easy cleaning. Saves money, time and labor.
2. **SMART4U® 3000 controller** helps control food and oil quality, oil life, and equipment performance.
3. **Sturdy basket hangers** are durable and easy to clean.
4. **Safe, self-standing heating elements** ensure industry leading energy efficiency and sealed rotation housing protects against oil migration.
5. **High limit auto reset** requires no tools or operator intervention and an **audible alarm** alerts if a second drain valve is opened.
6. **Robust product line** offers full and split frypots.
7. **Independent frypot construction** allows convenient frypot repairs in the field if needed.
8. **FootPrint PRO® built-in filtration** preserves oil life and ensures consistent, great-tasting food.
9. **Oil Attendant® auto fill option** senses the oil level and adds oil as needed from an in-cabinet supply.
10. **Adjustable leveling casters** accommodate all kitchen designs and floor types.



All OCF30E fryers meet ENERGY STAR® guidelines for high efficiency and are part of the Welbilt EnerLogic™ program.

FRYMASTER OIL-CONSERVING OCF30 ELECTRIC FRYERS

OCF30 FRYERS — With filtration, manual top-off, stainless steel frypot, door and sides.

MODEL	3000 CONTROLLER	OIL CAPACITY LBS.	COOK AREA W" X L" X D"	ELECTRICAL INPUT	SHIPPING WEIGHT LBS.
FPEL114C	\$23,040	30	13 x 14 x 3-3/4	14 kw	255

*Standard with 3000 Controller. Can substitute 3010 for 3000 controller at no additional cost. NOTES: ATO not available on single units.

OCF30 FRYER BATTERIES — With filtration, auto top-off, stainless steel frypots, doors and sides

MODEL	3000 CONTROLLER	OIL CAPACITY LBS.	COOK AREA W" X L" X D"	ELECTRICAL INPUT	SHIPPING WEIGHT LBS.
FPEL214CA	\$38,810	(2) 30	(2) 13 x 14 x 3-3/4	14 kw	535
FPEL314CA	\$53,255	(3) 30	(3) 13 x 14 x 3-3/4	14 kw	667

*Standard with 3000 Controller. Can substitute 3010 for 3000 controller at no additional cost.

STANDARD ACCESSORIES

- Built-in Filtration
- Casters
- Rack-type Basket Support
- ATO (except FPEL114C)
- Basket Hanger
- Twin Baskets
- Cords
- 8GPM Pump
- Jug in Box (JIB) Holder

POWER REQUIREMENTS, PER FRYPOT - BASIC DOMESTIC

MODELS	KW	ELEMENTS/FRYPOT			CONTROLS/FRYPOT	FILTER	AUTO TOP-OFF/FRYPOT	BASKET LIFTS/FRYPOT
		VOLTAGE	3 PHASE*	1 PHASE**				
FPELCA	14	208v	39 A	67 A	1A	5A	1A	2A
		240v	34 A	58 A	1A	4A	1A	2A
		480v	17 A	N/A	120v 1 A	120v 8 A	1A	120v 3 A

*3PH / 3 wire / plus ground wire **1PH / 2 wire / plus ground wire

NOTES:

- Split frypots — Add **\$4,915** for each split frypot.
- Basket Lifts— Add **\$4,915** for each frypot (full or split).
- Casters included in pricing.
- Tandem basket lifts — Add **\$180** each frypot (full or split).
- Any questions or pricing information other than the above should be referred to **Customer Service** .

FRYMASTER OIL-CONSERVING OCF30 ELECTRIC FRYERS

PART #	DESCRIPTION	PRICE
FRYER ACCESSORIES		
8030099	Basket, Full Size — 12-3/8 x 12-7/8 x 5-1/4 (Can't Be Used w/ Basket Lifts)	\$585
8030438	Basket, Triplet — 4-1/4 x 13-1/4 x 5-1/2	\$400
8030271	Basket, Twin Size — 5-7/8 x 12-5/8 x 6-5/8	\$400
8030132	Basket Support Rack, Full Pot 12-1/2 W x 13-3/4 D	\$280
8030106	Basket Support Rack, Split Pot 5-3/4 W x 13-1/2 D	\$250
8030429	Brush, L-Shaped Tampico 21" L x 2" Diameter	\$195
8030278	Brush, L-Shaped Teflon — 26-3/4" L x 1" Diameter	\$245
8239415	Covers, Split Pot	\$340
8238861	Chicken/Fish Tray, Full Pot 13 W x 13-1/2 D x 11 H (Not Available for Split Pot)	\$725
8030197	Clean-Out Rod — 27" Long	\$250
8238899	Cover, Stainless Steel, Full Pot 14-3/8 W x 19-1/2 D	\$565
8238065	Fish Plate — 13" x 13-1/2" x 4-1/2"	\$725
8030059	Fish Scoop 8-1/8 W x 8-1/2 D w/ 17-3/8 Handle	\$290
8030446	Fish Skimmer — No Hooks 6" Square w/ Insulated Handle	\$280
8238224	Splash Shield, Side — 19-1/2 W x 11-3/4 H	\$565

NOTES:

- One cord is provided per frypot.
- Plug is an optional accessory on units shipping with cord, except 480V 3 phase units — no plug is available.
EXCEPTION: Units shipping to Canada with a cord must have a plug as well.
- Optional plug — (Domestic: NEMA #15-60P) — Add **\$250** for each frypot.
- Controller, filter pump and basket lifts are powered by element voltages except 480V fryers.
- All 480 volt models are provided with separate 120V cord and plug for filter pump, controller and/or basket lifts.
- 480V 3PH option — Call customer service for price, per full or dual split frypot.
- No plug or cord is provided on single phase fryers.
- Any questions or pricing information other than the above should be referred to Customer Service .

DESCRIPTION	PRICE
SPECIAL OIL OPTIONS	

Semi-Solid/Solid Shortening* Call Customer Service before ordering	\$4,330
Bulk oil (dispose and fresh fill) on batteries* with built-in filtration	\$2,730

*Must be requested at time of order.

SPREADERS — ADD TO PRICE OF FRYER(S)

Spreader Cabinet — Call Customer Service
for availability and placement. **\$2,405**

PART #	DESCRIPTION	PRICE
--------	-------------	-------

FILTERING ACCESSORIES

8030002	Filter Powder (80, 1oz. Packs)	\$245
8030445	Filter Paper (16-1/2 x 25-1/2) Box of 100 Sheets	\$290

Frymaster®

RE High-Efficiency Electric Fryers

Put every kw to Work at Maximum Efficiency



1. Deliver award winning performance. The RE fryers have been recognized by the Electric Foodservice Council with a President Choice Award for outstanding contribution to the advancement of electric foodservice equipment.

2. Help keep the kitchen cool. With more energy going into the oil, there is less heat going into the ambient air which keeps workers comfortable and reduces demand on HVAC.

3. Have industry leading energy efficiency with ASTM ratings greater than 83%. RE fryers are ENERGY STAR® rated and qualify for energy saving rebates.

4. Can significantly extend oil life, saving thousands of dollars annually on oil costs with built-in filtration options that make it easy to preserve oil life and ensure great tasting food.

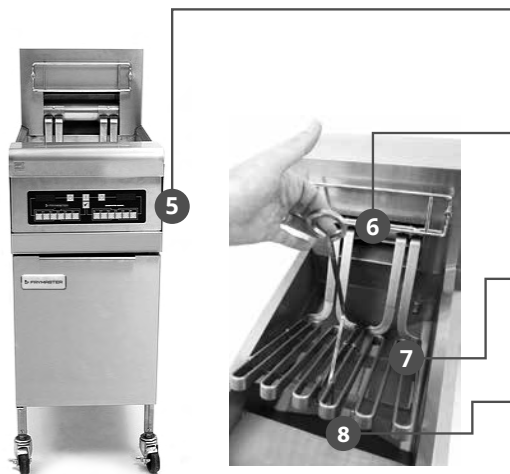

5. Support a broad range of frying needs with 14kw, 17kw, and 22kw models, controller options that add features all the way to cook compensation, and basket lift options.

6. Protect and conserve with safe, self-standing, swing-up, flat-bar heating elements that allow a highly efficient and uniform transfer of heat into the oil. A sealed rotation housing protects against oil migration.

7. Produce consistent, high quality food time after time. RTD temperature probe delivers precise heat response, safeguarding oil life and producing a uniformly-cooked product.

8. Are easy to clean. Open frypot design and sturdy self-standing elements allow safe access to every inch of the frypot.

RE Fryers deliver a lifetime of performance.



All E⁴ fryers meet ENERGY STAR guidelines for high efficiency and are part of the Welbilt EnerLogic program.

FRYMASTER ULTRA HIGH EFFICIENCY RETC ELECTRIC Fryers

RETC Fryers — Without filtration, stainless steel frypot, door and sides.

MODEL	CM 3.5 CONTROLLER	OIL CAPACITY LBS.	COOK AREA W" X L" X D"	ELECTRICAL INPUT	SHIPPING WEIGHT LBS.
RE14TC	\$17,135	50	14 x 15-1/2 x 3-3/4	14 kw	214
RE17TC	\$18,690	50	14 x 15-1/2 x 3-3/4	17 kw	214

14 KW RETC Fryers — With filtration, stainless steel frypot, door and sides.

MODEL	CM 3.5 CONTROLLER*	OIL CAPACITY LBS.	COOK AREA W" X L" X D"	ELECTRICAL INPUT	SHIPPING WEIGHT LBS.
FPRE214TC	\$49,205	(2) 50	(2) 14 x 15-1/2 x 3-3/4	(2) 14 kw	552
FPRE314TC	\$67,845	(3) 50	(3) 14 x 15-1/2 x 3-3/4	(3) 14 kw	705
FPRE414TC	\$86,510	(4) 50	(4) 14 x 15-1/2 x 3-3/4	(4) 14 kw	895

*Standard with CM3.5 controller | Filter Price Included. | Casters included in pricing.

17 KW RETC Fryers — With filtration, stainless steel frypot, door and sides.

MODEL	CM 3.5 CONTROLLER*	OIL CAPACITY LBS.	COOK AREA W" X L" X D"	ELECTRICAL INPUT	SHIPPING WEIGHT LBS.
FPRE217TC	\$52,320	(2) 50	(2) 14 x 15-1/2 x 3-3/4	(2) 17 kw	552
FPRE317TC	\$72,520	(3) 50	(3) 14 x 15-1/2 x 3-3/4	(3) 17 kw	705
FPRE417TC	\$92,725	(4) 50	(4) 14 x 15-1/2 x 3-3/4	(4) 17 kw	895

*Standard with CM3.5 controller | Filter Price Included. | Casters included in pricing.

STANDARD ACCESSORIES

- TRIAC Controls
- Automatic Melt Cycle
- Boil Out Temperature Control
- Legs (non-filter fryers)
- Rack-type Basket Support
- Basket Hanger
- Twin Baskets
- Casters (filter models)
- Cord (14 kW)

NOTES:

- Split frypots – Add \$2,925 for each split frypot.
- Basket Lifts – Add \$3,835 for each frypot (full or split).
- Standard supplies for all filter systems consist of sample packages of filter powder and paper, one filter brush and one clean-out rod.

MODELS	KW	ELEMENTS/FRYPOT			CONTROLS/FRYPOT	FILTER	BASKET LIFTS/FRYPOT
		VOLTAGE	3 PHASE*	1 PHASE**			
RE14TC	14	208v	39 A	67 A	1A	5A	2A
RE14-2TC	(2) 7	240v	34 A	58 A	1A	4A	2A
RE17TC	17	208v	48 A	82 A	1A	5A	2A
RE17-2TC	(2) 8.5	240v	41 A	71 A	1A	4A	2A

*3PH / 3 wire / plus ground wire **1PH / 2 wire / plus ground wire

* 3PH / 3 wire / plus ground wire ** 1PH / 2 wire / plus ground wire

FRYMASTER ULTRA HIGH EFFICIENCY RETC ELECTRIC Fryers

PART #	DESCRIPTION	PRICE
FRYER ACCESSORIES		
8030099	Basket, Full Size — 12-3/8 x 12-7/8 x 5-1/4 (Can't Be Used w/ Basket Lifts)	\$585
8030271	Basket, Twin Size — S 5-7/8 x 12-5/8 x 6-5/8	\$400
8030357	Basket, Triplet — 4-1/2 x 13-1/4 x 6	\$400
8102793	Basket Hanger — 12-1/2 W x 3-1/2 H	\$280
8030132	Basket Support Rack, Full Pot 12-1/2 W x 13-3/4 D	\$280
8030106	Basket Support Rack, Split Pot 5-3/4 W x 13-1/2 D	\$250
8030136	Basket Support Screen, Full Pot 12-1/2 W x 13-3/4 D	\$340
8030429	Brush, L-Shaped Tampico 21" L x 2" Diameter	\$195
8030278	Brush, L-Shaped Teflon 26-3/4" L x 1" Diameter	\$245
	Casters — Set of 4	\$650
8239415	Covers, Split Pot	\$340
8030197	Clean-Out Rod — 27" Long	\$250
8239414	Cover, Stainless Steel, Full Pot, Basket Lifts 14-5/8 W x 19-3/8 D	\$565
8030059	Fish Scoop 8-1/8 W x 8-1/2 D w/ 17-3/8 Handle	\$290
8030446	Fish Skimmer — No Hooks 6" Square w/ Insulated Handle	\$280
	Legs - 8-1/2" — Set of four	\$650
8030358	Sediment Tray — Full Pot 10-1/2 x 1-5/8 x 4	\$955
8236559	Splash Shield — 20 D x 6-1/8 H	\$565
8235810	Top Connecting Strip	\$350
2208964	Chicken/Fish Plate — Full Pot 13-5/8 W x 14-1/4 D	\$725
8030360L 8030359R	Sediment tray — Split Pot 4-5/8 x 13-7/8 x 4	\$725

NOTES:

- TC models not available in 480V.
- Plug is optional accessory on units shipping with a cord
EXCEPTION: Units shipping to Canada with a cord must have a plug as well.
- Optional plug — (Domestic: NEMA #15-60P) — Add \$250 for each frypot.
- All single phase units must be field wired. No plug or cord provided. Check electrical code for proper supply line sizing.
- Controller, filter pump and basket lifts are powered by element voltages.
- RETC models not available in 480V.
- Any questions or pricing information other than the above should be referred to Customer Service .

DESCRIPTION	PRICE
SPECIAL OIL OPTIONS	

External oil discharge — available on built-in filter batteries of 2 or more frypots or a frypot and spreader. Must specify front or rear connection. Front connection comes with 5ft. washdown hose.

FRONT \$2,730

REAR \$2,090

SPREADERS — ADD TO PRICE OF FRYER(S)	
Spreader Cabinet — Call Customer Service for availability and placement.	\$2,405

PART #	DESCRIPTION	PRICE
--------	-------------	-------

FILTERING ACCESSORIES		
8030002	Filter Powder (80, 1oz. Packs)	\$245
8030170	Filter Paper (19-1/2 x 27-1/2) Box of 100 sheets	\$290

FRYMASTER HIGH EFFICIENCY RE ELECTRIC FRYERS

RE FRYERS — Without filtration, stainless steel frypot, door and sides.

MODEL NUMBER	DIGITAL TIMER CONTROLLER	CM 3.5 CONTROLLER*	OIL CAPACITY LBS.	COOK AREA W" X L" X D"	ELECTRICAL INPUT	SHIPPING WEIGHT LBS.
RE14	\$12,575	\$12,575	50	14 x 15-1/2 x 3-1/2	14 kw	190
RE17	\$14,030	\$14,030	50	14 x 15-1/2 x 3-1/2	17 kw	277

*Standard with CM3.5 controller.

14 KW FRYERS — With filtration, stainless steel frypot(s), door(s) and sides.

MODEL NUMBER	DIGITAL TIMER CONTROLLER	CM 3.5 CONTROLLER*	OIL CAPACITY LBS.	COOK AREA W" X L" X D"	ELECTRICAL INPUT	SHIPPING WEIGHT LBS.
FPRE114	\$26,170	\$26,170	50	14 x 15-1/2 x 3-1/2	14 kw	277
FPRE214	\$40,070	\$40,070	(2) 50	(2) 14 x 15-1/2 x 3-1/2	(2) 14 kw	459
FPRE314	\$54,170	\$54,170	(3) 50	(3) 14 x 15-1/2 x 3-1/2	(3) 14 kw	612
FPRE414	\$68,250	\$68,250	(4) 50	(4) 14 x 15-1/2 x 3-1/2	(4) 14 kw	811

*Standard with CM3.5 controller. NOTES: Filter price included. | Casters included in pricing.

17 KW FRYERS — With filtration, stainless steel frypot(s), door(s) and sides.

MODEL NUMBER	DIGITAL TIMER CONTROLLER	CM 3.5 CONTROLLER*	OIL CAPACITY LBS.	COOK AREA W" X L" X D"	ELECTRICAL INPUT	SHIPPING WEIGHT LBS.
FPRE117	\$27,635	\$27,635	50	14 x 15-1/2 x 3-1/2	17 kw	277
FPRE217	\$42,975	\$42,975	(2) 50	(2) 14 x 15-1/2 x 3-1/2	(2) 17 kw	459
FPRE317	\$58,540	\$58,540	(3) 50	(3) 14 x 15-1/2 x 3-1/2	(3) 17 kw	612
FPRE417	\$74,080	\$74,080	(4) 50	(4) 14 x 15-1/2 x 3-1/2	(4) 17 kw	811

*Standard with CM3.5 controller. NOTES: Filter price included. | Casters included in pricing.

FRYMASTER HIGH EFFICIENCY RE ELECTRIC FRYERS

STANDARD ACCESSORIES

- Automatic Melt Cycle
- Boil Out Temperature Control
- Legs (non-filter fryers)
- Rack-type Basket Support
- Basket Hanger
- Twin Baskets
- Casters (filter models)
- Cord (14 kW)

NOTES:

- Add **\$3,095** for each split frypot.
- Add **\$3,645** /FRYPOT for basket lifts. Casters included in basket lift pricing.
- Standard supplies for all filter systems consist of sample packages of filter powder and paper, one filter brush and one clean-out rod.

POWER REQUIREMENTS, PER FRYPOT — BASIC DOMESTIC

MODELS	KW	ELEMENTS/FRYPOT			CONTROLS/ FRYPOT	FILTER	BASKET LIFTS/ FRYPOT
		VOLTAGE	3 PHASE*	1 PHASE**			
RE14	14	208v	39 A	67 A	1A	5A	2A
RE14-2	(2) 7	240v	34 A	58 A	1A	4A	2A
		480v	17 A	N/A	120v 1 A	120v 8 A	120v 3 A
RE17	17	208v	48 A	82 A	1A	5A	2A
RE17-2	(2) 8.5	240v	41 A	71 A	1A	4A	2A
		480v	21 A	N/A	1A	4A	2A

*3PH / 3 wire / plus ground wire **1PH / 2 wire / plus ground wire

FRYMASTER HIGH EFFICIENCY RE ELECTRIC FRYERS

PART #	DESCRIPTION	PRICE
FRYER ACCESSORIES		
8030099	Basket, Full Size — 12-3/8 x 12-7/8 x 5-1/4 (Can't Be Used w/ Basket Lifts)	\$585
8030271	Basket, Twin Size — 5-7/8 x 12-5/8 x 6-5/8	\$400
8030357	Basket, Triplet Size — 4-1/2 x 13-1/4 x 6	\$400
8102793	Basket Hanger — 12-1/2 W x 3-1/2 H	\$280
8030132	Basket Support Rack, Full Pot 2-1/2 W x 13-3/4 H	\$280
8030106	Basket Support Rack, Split Pot 5-3/4 W x 13-1/2 D	\$250
8030136	Basket Support Screen, Full Pot 12-1/2 W x 13-3/4 H	\$340
8030429	Brush, L-Shaped Tampico — 21" L x 2" Diameter	\$195
8030278	Brush, L-Shaped Teflon 26-3/4" L x 1" Diameter	\$245
	Casters —Set of 4 Call Customer Service to specify model	\$650
2208964	Chicken/Fish Plate — Full Pot 13-5/8 W x 14-1/4 D	\$725
8030197	Clean-Out Rod — 27" Long	\$250
8239414	Cover, Stainless Steel, Full Pot 14-5/8 W x 19-3/8 D	\$565
8030059	Fish Scoop 8-1/8 W x 8-1/2 D w/ 17-3/8 Handle	\$290
8030446	Fish Skimmer, No Hooks 6" Square w/ Insulated Handle	\$280
	Foam Deck Basket Banger*	\$455/ FRYPOT
	Legs - 8-1/2" — Set of four, Adjustable	\$650
8030358	Sediment tray — Full Pot 10-1/2 x 11-5/8 x 4	\$955
8030360L 8030359R	Sediment tray — Split Pot 4-5/8 x 13-7/8 x 4	\$725
8236559	Splash Shield — 20 D x 6-1/8 H	\$565
8235810	Top Connecting Strip	\$350
8239415	Cover, Split Pot	\$340

*If ordered after fryer purchase, requires changing top connecting strip(s).

NOTES:

- Plug is optional accessory on units shipping with a cord except 480V 3 phase units — no plug is available.
EXCEPTION: Units shipping to Canada with a cord must have a plug as well.
- Optional plug - (Domestic: NEMA #15-60P) — Add \$250 for each frypot.
- Single phase units must be field wired. No plug or cord provided. Check electrical code for proper supply line sizing.
- Single phase fryers with built-in filter are available in 240V and 208V only.
- Controller, filter pump and basket lifts are powered by element voltages except 480V fryers.
- All 480V models are provided with separate 120 volt cord and plug for filter pump, and/or controller, and/or basket lifts.
- 480V 3PH option — Call customer service for price, per full or dual split frypot.
- No plug or cord is provided on single phase fryers.
- Any questions or pricing information other than the above should be referred to Customer Service .

DESCRIPTION	PRICE
SPREADERS — ADD TO PRICE OF FRYER(S)	

Spreader Cabinet — Call Customer Service for availability and placement. **\$2,405**

DESCRIPTION	PRICE
EXTERNAL OIL DISCHARGE OPTIONS	

External oil discharge — available on built-in filter batteries of 2 or more frypots or a frypot and spreader. Must specify front or rear connection. Front connection comes with 5ft. washdown hose.

FRONT \$2,730

REAR \$2,090

PART #	DESCRIPTION	PRICE
FILTERING ACCESSORIES		

8030002 Filter Powder (80, 1oz. Packs) **\$245**

8030170 Filter Paper (19-1/2 x 27-1/2) Box of 100 sheets **\$290**

FRYMASTER HIGH PRODUCTION HIGH EFFICIENCY RE80 ELECTRIC FRYERS

17 KW FRYER — Without filtration, stainless steel frypot, door and sides.

MODEL NUMBER	DIGITAL TIMER CONTROLLER*	CM 3.5 CONTROLLER	3000 CONTROLLER	OIL CAPACITY LBS.	COOK AREA W" X L" X D"	ELECTRICAL INPUT	SHIPPING WEIGHT LBS.
RE180	\$16,145	\$19,920	\$20,690	80	18 x 18 x 4-3/8	17 kw	285

*Standard with Digital timer controller.

21 KW FRYER — Without filtration, stainless steel frypot, door and sides.

MODEL NUMBER	DIGITAL TIMER CONTROLLER*	CM 3.5 CONTROLLER	3000 CONTROLLER	OIL CAPACITY LBS.	COOK AREA W" X L" X D"	ELECTRICAL INPUT	SHIPPING WEIGHT LBS.
RE180	\$17,845	\$21,450	\$22,215	80	18 x 18 x 4-3/8	21 kw	285

*Standard with Digital timer controller.

17 KW FRYERS — With filtration, stainless steel frypot(s), door(s) and sides.

MODEL NUMBER	DIGITAL TIMER CONTROLLER*	CM 3.5 CONTROLLER	3000 CONTROLLER	OIL CAPACITY LBS.	COOK AREA W" X L" X D"	ELECTRICAL INPUT	SHIPPING WEIGHT LBS.
FPRE180	\$27,540	\$31,335	\$32,095	80	18 x 18 x 4-3/8	17 kw	359
FPRE280	\$50,810	\$58,390	\$59,905	(2) 80	(2) 18 x 18 x 4-3/8	17 kw	617
FPRE380	\$68,730	\$80,105	\$82,385	(3) 80	(3) 18 x 18 x 4-3/8	17 kw	816
FPRE480	\$86,680	\$101,830	\$104,880	(4) 80	(4) 18 x 18 x 4-3/8	17 kw	1,044

*Standard with Digital timer controller.

21KW FRYERS — With filtration, stainless steel frypot(s), door(s) and sides.

MODEL NUMBER	DIGITAL TIMER CONTROLLER*	CM 3.5 CONTROLLER	3000 CONTROLLER	OIL CAPACITY LBS.	COOK AREA W" X L" X D"	ELECTRICAL INPUT	SHIPPING WEIGHT LBS.
FPRE180	\$29,255	\$32,855	\$33,600	80	18 x 18 x 5	21 kw	359
FPRE280	\$54,210	\$61,405	\$62,935	(2) 80	(2) 18 x 18 x 5	21 kw	617
FPRE380	\$73,870	\$84,650	\$86,950	(3) 80	(3) 18 x 18 x 5	21 kw	816
FPRE480	\$93,505	\$107,905	\$110,925	(4) 80	(4) 18 x 18 x 5	21 kw	1,044

*Standard with Digital timer controller.

NOTES:

- Filter price included.
- Casters included in basket lift pricing
- Standard filter supplies include sample packages of filter powder and paper, one filter brush and one clean-out rod and gloves.
- Add **\$5,465** /frypot for basket lifts. Casters included in pricing.
- Tandem basket lifts – Add **\$180** each frypot.
- Split pots not available.

STANDARD ACCESSORIES

- Automatic Melt Cycle
- Boil Out Temperature Control
- Legs (non-filter fryers)
- Casters (filter models)
- Cords (17 kw)
- Screen-type Basket Support
- Basket Hanger
- Twin Baskets
- 8 GPM Pump

POWER REQUIREMENTS, PER FRYPOT — BASIC DOMESTIC

MODELS	KW	ELEMENTS/FRYPOT		CONTROLS/FRYPOT	FILTER	BASKET LIFTS/FRYPOT
		VOLTAGE	3 PHASE*			
RE180	17	208v 240v 480v	48 A 41 A 21 A	1A 1A 120v 1 A	5A 4A 120v 8 A	2A 2A 120v 3 A
RE180	21	208v 240v 480v	57 A 51 A 26 A	1A 1A 120v 1 A	5A 4A 120v 8 A	2A 2A 120v 3 A

*3PH / 3 wire / plus ground wire

FRYMASTER HIGH PRODUCTION HIGH EFFICIENCY RE80 ELECTRIC FRYERS

PART #	DESCRIPTION	PRICE
FRYER ACCESSORIES		
8030148	Basket, Full Size — 16-3/4 x 17-1/2 x 5-3/4	\$610
8030304	Basket, Twin Size — 8-3/4 x 16-3/4 x 6	\$400
8030306	Basket, Twin Size, Basket Lifts 7-5/8 x 15-7/8 x 7-3/8	\$425
8030427	Basket, Triplet Size — 5-5/8 x 15-7/8 x 7-1/4	\$425
8102794	Basket Hanger — 17-3/8 W x 3-1/2 H	\$280
8030387	Basket Support Rack, Fine Mesh 17-3/8" x 17-5/8"	\$340
8030429	Brush, L-Shaped Tampico 21" L x 2" Diameter	\$195
8030278	Brush, L-Shaped Teflon 26-3/4" L x 1" Diameter	\$245
8237109	Splash Shield	\$565
8233947	Chicken/Fish Tray — 16-1/2 x 16-1/2 x 11	\$810
8030197	Clean-Out Rod — 27" Long	\$250
1080220	Frypot Cover 20" x 22-1/4" x 1-1/2" with Handle	\$675
8030059	Fish Scoop 8-1/8 W x 8-1/2 D w/ 17-3/8 Handle	\$290
8030446	Fish Skimmer, No Hooks 6" Square w/ Insulated Handle	\$280
	Foam Deck Basket Banger*	\$455/ FRYPOT
2305382	Top Connecting Strip	\$380
	CASTERS - set of four (non-filter models)	\$650

*If ordered after fryer purchase, requires changing top connecting strip(s).

NOTES:

- All 21 kw units must be field wired. No plug or cord provided. Check electrical code for proper supply line sizing.
- Plug is an optional accessory on units shipping with cord, except 480V 3 phase units — no plug is available.
EXCEPTION: Units shipping to Canada with a cord must have a plug as well.
- Optional plug — (Domestic: NEMA #15-60P) — Add **\$230** for each full or dual split frypot.
- Controller, filter pump and basket lifts are powered by element voltages except 480V fryers.
- All 480V models are provided with separate 120 volt cord and plug for filter pump, controller, and/or basket lifts.
- 480V 3PH option — Call customer service for price, per full or dual split frypot.
- No plug or cord is provided on single phase fryers.
- Any questions or pricing information other than the above should be referred to Customer Service .

DESCRIPTION	PRICE
SPREADERS — ADD TO PRICE OF FRYER(S)	

Spreader Cabinet, 20MC — Call Customer Service for availability and placement. **\$3,185**

DESCRIPTION	PRICE
EXTERNAL OIL DISCHARGE	

External oil discharge — available on built-in filter batteries of 2 or more frypots or a frypot and spreader. Must specify front or rear connection. Front connection comes with 5ft. washdown hose.

FRONT \$2,730

REAR \$2,090

PART #	DESCRIPTION	PRICE
--------	-------------	-------

FILTERING ACCESSORIES

8030002	Filter Powder (80, 1oz. Packs)	\$245
8030345	60 Fryer, SUFF* Equipped, 33-1/4 x 17 Box Of 100 Sheets	\$470
8030303	80/100 Series Fryer, 100 Uff** Filter Paper 26 x 34 Box Of 100 Sheets	\$470
8239077	Filter Screen (high sediment) 11-1/2 W x 16-3/8 D — 2 required	\$675/ EACH

*SUFF-Equipped systems are single frypots with built-in filtration only.

**UFF-Equipped systems are multi-batteried frypots with built-in filtration only.

DEAN DECATHLON (D) GAS FRYERS

DECATHLON FRYER — Without filtration, stainless steel frypot, door and sides.

MODEL NUMBER	THERMATRON CONTROLLER	OIL CAPACITY LBS.	COOK AREA W" X L" X D"	BTU/HR INPUT	SHIPPING WEIGHT LBS.
D160G	\$10,745	75	18 x 18 x 3-3/4	150,000	255

NOTES: Split pots not available.

DECATHLON D60 FRYERS — With filtration, stainless steel frypots, door(s) and sides.

MODEL NUMBER	THERMATRON CONTROLLER	OIL CAPACITY LBS.	COOK AREA W" X L" X D"	BTU/HR INPUT	SHIPPING WEIGHT LBS.
SCFD260G	\$32,335	(2) 75	(2) 18 x 18 x 3-3/4	(2) 150,000	417
SCFD360G	\$44,720	(3) 75	(3) 18 x 18 x 3-3/4	(3) 150,000	815
SCFD460G	\$57,080	(4) 75	(4) 18 x 18 x 3-3/4	(4) 150,000	1295

NOTES: Filter price included. | Casters included in pricing. | Split pots not available.

STANDARD ACCESSORIES

- Automatic Melt Cycle
- Boil Out Temperature Control
- Legs (non-filter fryers)
- Casters (filter models)
- Rack-type Basket Support
- Basket Hanger
- Twin Baskets

PART #	DESCRIPTION	PRICE
--------	-------------	-------

FILTERING ACCESSORIES

	8GPM Filter Pump Upgrade (Systems Only)	\$930
8030293	Gloves, Black Safety	\$175
8233696	Sediment Scoop	\$180
8030002	Filter Powder (80, 1oz. Packs)	\$245
8030289	Filter Paper (22 x 34) Box Of 100 Sheets	\$470

NOTES:

- If elevation is between 2,000 - 6,000 feet, specify the elevation level. Fryer may not perform at optimum levels above this elevation.
- Any questions or pricing information other than the above should be referred to **Customer Service**.

DEAN GAS LINE TABLE

# OF FRYERS	GAS LINE WITHOUT FILTER	GAS LINE WITH FILTER
	SINGLES	
1	3/4"	N/A
2-4	N/A	(1) 1"

DESCRIPTION

PRICE

SPREADERS — ADD TO PRICE OF FRYER(S)

Spreader Cabinet, 20MC — Call Customer Service for availability and placement. **\$2,695**

GAS MANIFOLD REQUIREMENTS

1" Rear Gas Manifold (Per Fryer)	WITH FILTER: With Shut-Off Valve	\$185
	Without Shut-Off Valve	Standard

DESCRIPTION

PRICE

EXTERNAL OIL DISCHARGE

External oil discharge — available on built-in filter batteries of 2 or more frypots or a frypot and spreader. Must specify front or rear connection. Front connection comes with 5ft. washdown hose.

FRONT \$2,730

REAR \$2,090

DEAN DECATHLON (D) GAS FRYERS

(CONTINUED)

PART #	DESCRIPTION	PRICE
FRYER ACCESSORIES		
8030017	Basket, Full Size, D60G — 17-1/2 x 16-3/4 x 6	\$610
8030427	Basket, Triplet Size, D60G — 5-5/8 x 15-7/8 x 7-1/4	\$425
8030304	Basket, Twin Size, D60G — 8-3/4 x 16-3/4 x 6	\$400
8102235	Basket Support Rack, D60G — 17-3/8 W x 17-5/8 D	\$405
8030149	Basket Support Rack, Fine Mesh, HD60G & D60 — 17 W x 17 D	\$400
8030429	Brush, L-Shaped Tampico — 21" L x 2" Diameter	\$195
8030278	Brush, L-Shaped Teflon — 26-3/4" L x 1" Diameter	\$245
	CASTERS — Set of Four (Non Filter Models Only)	\$650
8233947	Chicken/Fish Tray, HD60G & D60 — 16-1/2 x 16-1/2 x 11	\$810
8030197	Clean-Out Rod — 27" Long	\$250
8235744	Splash Shield, HD60G & D60	\$340
1061479	Cover, Frypot without Basket Lift, D60G — 23-3/8 W x 19-3/8 D	\$665
1062773	Cover, Frypot with Basket Lift, D60G — 18 W x 22-5/8 D	\$665
8030059	Fish Scoop — 8-1/8 W x 8-1/2 D w/ 17-3/8 Handle	\$290
8030446	Fish Skimmer, No Hooks 6" Square w/ Insulated Handle	\$280
8061698	Quick Disconnect Hose — 1" Gas Line, 36" Long	\$1,255
8061699	Quick Disconnect Hose — 1" Gas Line, 48" Long	\$1,345
8061701	Quick Disconnect Hose — 3/4" Gas Line, 36" Long	\$1,015
8061700	Quick Disconnect Hose — 3/4" Gas Line, 48" Long	\$1,105
1062631	Sediment Tray, HD60G — 17-3/4 W x 17-1/8 D	\$1,160
2105086	Top Connecting Strip, HD60G & D60 — 2 W x 23-5/8 D	\$350

DEAN®

PowerRunner™ Gas Tube Fryers

Designed for durability and versatility

SEE WHY Our PowerRunner Fryers are the NEW mid-size fryer of choice!

- 1. 50-lb. frypot capacity.** High-production cooking capacity and fast recovery meet high volume frying needs in this 14" frypot.
- 2. Multiple controller options.** There are four controller options: millivolt, thermatron, digital timer, and CM3.5.
- 3. Proven tube fryer design.** The Thermo-Tube heat transfer system ensures outstanding reliability and durability.
- 4. Built-in filter options.** Makes filtration quick, convenient, and reliable. Filtration extends oil life, reduces operating expense, and preserves food quality.
- 5. Multiple battery options.** This fryer is available as a single unit or a multi-battery unit (two to four frypots).
- 6. Accommodates a variety of frying needs.** Everything from French fries, breaded products and specialty foods.



1PRG50T gas fryer shown with optional casters

DEAN POWERRUNNER™ (PR) GAS FRYERS

POWERRUNNER FRYERS — Without filtration, stainless steel frypot(s), door(s) and sides.

MODEL NUMBER	MILLIVOLT CONTROLLER*	THERMATRON CONTROLLER	DIGITAL TIMER CONTROLLER	CM3.5 CONTROLLER	OIL CAPACITY LBS.	COOK AREA W" X L" X D"	BTU/HR INPUT	SHIPPING WEIGHT LBS.
1PRG50T	\$8,180	\$8,915	\$9,740	\$13,010	(1) 50	(1) 14 x 14 x 3-1/2	(1) 120000	188
2PRG50T	\$16,350	\$17,815	\$19,480	\$26,015	(2) 50	(2) 14 x 14 x 3-1/2	(2) 120,000	404
3PRG50T	\$24,540	\$26,730	\$29,215	\$39,020	(3) 50	(3) 14 x 14 x 3-1/2	(3) 120,000	572
4PRG50T	\$32,715	\$35,630	\$38,950	\$52,035	(4) 50	(4) 14 x 14 x 3-1/2	(4) 120,000	772

*Standard with Millivolt controller.

POWERRUNNER FRYERS — With filtration, stainless steel frypot(s), door(s) and sides.

MODEL NUMBER	MILLIVOLT CONTROLLER*	THERMATRON CONTROLLER	DIGITAL TIMER CONTROLLER	CM3.5 CONTROLLER	OIL CAPACITY LBS.	COOK AREA W" X L" X D"	BTU/HR INPUT	SHIPPING WEIGHT LBS.
1FPRG50T	\$19,095	\$19,825	\$20,645	\$23,895	(1) 50	(1) 14 x 14 x 3-1/2	(1) 120000	397
2FPRG50T	\$29,375	\$30,820	\$32,400	\$38,275	(2) 50	(2) 14 x 14 x 3-1/2	(2) 120,000	397
3FPRG50T	\$39,560	\$41,695	\$43,985	\$55,700	(3) 50	(3) 14 x 14 x 3-1/2	(3) 120,000	610
4FPRG50T	\$49,085	\$51,900	\$55,095	\$67,860	(4) 50	(4) 14 x 14 x 3-1/2	(4) 120,000	910

*Standard with Millivolt controller. NOTES: Filter price included. | Casters included in pricing.

STANDARD ACCESSORIES

- Legs (non-filter models)
- Casters (filter models)
- Basket Hanger
- Rack-type Basket Support
- Twin Baskets

PART #	DESCRIPTION	PRICE
--------	-------------	-------

FILTERING ACCESSORIES

	8GPM Filter Pump Upgrade (Systems Only)	\$930
8030293	Gloves, Black Safety	\$175
8233696	Sediment Scoop	\$180
8030002	Filter Powder (80, 1oz. Packs)	\$245
8030289	50 Series Fryer, UFF* Equipped, 34 x 22 — Box Of 100 Sheets	\$470

*UFF-Equipped systems are multi-batteried frypots with built-in filtration only.

NOTES:

- Add \$4,375 /frypot for basket lifts (only available with CM3.5. Casters included in pricing.
- Tandem basket lifts – Add \$180 each frypot.
- If elevation is between 2,000 - 6,000 feet, specify the elevation level. Fryer may not perform at optimum levels above this elevation.
- Any questions or pricing information other than the above should be referred to **Customer Service**.

DEAN GAS LINE TABLE

# OF FRYERS	GAS LINE
1	3/4"
2-4	N/A

DESCRIPTION

PRICE

SPREADERS — ADD TO PRICE OF FRYER(S)

Spreader Cabinet, 15MC — Call Customer Service for availability and placement. **\$1,980**

GAS MANIFOLD REQUIREMENTS

1" Rear Gas Manifold (Per Fryer)	WITH FILTER: With Shut-Off Valve	\$185
	Without Shut-Off Valve	Standard

DESCRIPTION

PRICE

EXTERNAL OIL DISCHARGE

External oil discharge — available on built-in filter batteries of 2 or more frypots or a frypot and spreader. Must specify front or rear connection. Front connection comes with 5ft. washdown hose.

FRONT \$2,730

REAR \$2,090

DEAN POWERRUNNER™ (PR) GAS FRYERS

(continued)

PART #	DESCRIPTION	PRICE
FRYER ACCESSORIES		
8030099	Basket, Full Size — 12-3/8 x 12-7/8 x 5-1/4	\$585
8030357	Basket, Triplet — 4-1/2 x 13-1/4 x 6	\$400
8030271	Basket, Twin Size — 5 5-7/8 x 12-5/8 x 6-5/8	\$400
8030273	Basket Support Rack — 13-1/2 W x 13-1/4 D	\$280
8030277	Basket Support Rack, Fine Mesh, — 13-1/2 W x 13-1/4 D	\$340
8030429	Brush, L-Shaped Tampico — 21" L x 2" Diameter	\$195
8030278	Brush, L-Shaped Teflon — 26-3/4" L x 1" Diameter	\$245
	CASTERS — Set of Four (Non Filter Models Only)	\$650
8236895	Chicken/Fish Tray — 13-1/2 x 13-1/2 x 11	\$400
8030197	Clean-Out Rod — 27" Long	\$250
1061637	Cover, Frypot without Basket Lift — 15 W x 21-3/8 D	\$565
8030059	Fish Scoop — 8-1/8 W x 8-1/2 D w/ 17-3/8 Handle	\$290
8030446	Fish Skimmer, No Hooks 6" Square w/ Insulated Handle	\$280
	Legs - 6" H, Set of Four, Adjustable (Non-filter Models Only)	\$650
8061698	Quick Disconnect Hose — 1" Gas Line, 36" Long	\$1,255
8061699	Quick Disconnect Hose — 1" Gas Line, 48" Long	\$1,345
8061701	Quick Disconnect Hose — 3/4" Gas Line, 36" Long	\$1,015
8061700	Quick Disconnect Hose — 3/4" Gas Line, 48" Long	\$1,105
1064136	Sediment Tray — 13-1/2 W x 13-3/4 D	\$985
8233225	Splash Shield — 21-1/2 D x 13 H	\$340
2102681	Top Connecting Strip — 2 W x 21-3/8 D	\$350



Super Runner Fryers (Gas and Electric)

Outpace the Competition in Performance and Value



SR42 gas fryer shown with optional casters



SR14 electric fryer shown with optional casters



SR62 electric fryer shown with optional casters

- 1. Meet varied production capacity needs.** Model offerings provide 40-75 lb. oil capacity options.
- 2. Can be utilized in operations with gas or electric utilities.** There are four models, three gas and one electric.
- 3. Offer two gas frypot sizes: 14" x 14" and 18" x 18".**
- 4. Have a low warranty failure rate.**
- 5. Have sturdy, long-lasting construction** that includes stainless-steel frypot, door, and backsplash/flue cover.
- 6. Require no electrical hook-up for gas models.**
- 7. Offer an electric model that helps the kitchen stay cool.** Electric elements transfer heat directly to the oil so the kitchen stays cooler.
- 8. Protect against high-heat ignition with reliable high-limit probe.** Gas flow automatically shuts off if temperature exceeds the upper limit.
- 9. Support frying operations with durable accessories** including frypot covers, full size baskets, fine mesh screen, and casters. Triplet baskets are available for the SR62 model's 18" x 18" frypot.

Super Runner Fryers are the front running value fryer of choice.

For more information, contact Customer Service at 1-800-221-4583 or visit www.frymaster.com.

DEAN SUPER RUNNER (SR) GAS FRYERS

SR FRYERS — With stainless steel frypot, front, door and aluminized sides.

MODEL NUMBER	MILLIVOLT CONTROLLER	OIL CAPACITY LBS.	COOK AREA W" X L" X D"	BTU/HR INPUT	SHIPPING WEIGHT LBS.
SR142G	\$2,270	43	14 x 13-3/4 x 4-1/5	105,000	150
SR152G	\$3,610	50	14 x 14 x 3-1/2	120,000	180
SR162G	\$5,065	75	18 x 18 x 3-3/4	150,000	255

STANDARD ACCESSORIES

- Legs (non-filter models)
- Basket Hanger
- Rack-type Basket Support
- Twin Baskets

NOTES:

- Split pot not available.
- If ordering for elevation above 2000 feet, high elevation kit is required. Contact local service agent to order kits.
- Any questions or pricing information other than the above should be referred to **Customer Service**.

PART #	DESCRIPTION	PRICE
--------	-------------	-------

FRYER ACCESSORIES

8030099	Basket, Full Size, SR42 & SR52 12-3/8 x 12-7/8 x 5-1/4	\$585
8030017	Basket, Full Size, SR62 17-1/2 x 16-3/4 x 6	\$610
8030271	Basket, Twin Size, SR42 & SR52 5-7/8 x 12-5/8 x 6-5/8	\$400
8030304	Basket, Twin Size, SR62 8-3/4 x 16-3/4 x 6	\$400
8030427	Basket, Triplet Size, SR62 5-5/8 x 15-7/8 x 7-1/4	\$425
8102793	Basket Hanger, SR42 & SR52 12-1/2 W x 3-1/2 H	\$280
8102794	Basket Hanger, SR62 — 17-3/8 W x 3-1/2 H	\$280
8030273	Basket Support Rack, SR42 & SR52 13-1/2 W x 13-1/4 D	\$280
8102235	Basket Support Rack, SR62 17-3/8 W x 17-5/8 D	\$405
8030277	Basket Support Rack, Fine Mesh, SR42 & SR52 — 13-1/2 W x 13-1/4 D	\$340
8030149	Basket Support Rack, Fine Mesh, SR62 17 W x 17 D	\$400
8030278	Brush, L-Shaped Teflon 26-3/4" L x 1" Diameter	\$245
8030429	Brush, L-Shaped Tampico 21" L x 2" Diameter	\$195
	CASTERS - Set of Four	\$650
8030197	Clean-Out Rod — 27" Long	\$250
1061637	Cover, Frypot, SR42 & SR52 13-1/2 W x 21-3/8 D	\$565
1061479	Cover, Frypot w/o Basket Lift, SR62 23-3/8 W x 19-3/4 D	\$665
2102681	Top Connecting Strip, SR42 & SR52 2 W x 21-3/8 D	\$350
2105086	Top Connecting Strip, SR62 — 2 W x 23-5/8 D	\$350
8233696	Sediment Scoop	\$180
8030059	Fish Scoop 8-1/8 W x 8-1/2 D w/ 17-3/8 Handle	\$195
8030446	Fish Skimmer, No Hooks 6" Square w/ Insulated Handle	\$280

DEAN SUPER RUNNER (SRE) ELECTRIC FRYERS

SRE FRYERS — With stainless steel frypot, front, door and aluminized sides.

MODEL NUMBER	MILLIVOLT CONTROLLER	OIL CAPACITY LBS.	COOK AREA W" X L" X D"	BTU/HR INPUT	SHIPPING WEIGHT LBS.
SR114E	\$5,230	40	13-3/4 x 13-3/4 x 5-1/4	14 kw	180

STANDARD ACCESSORIES

- Legs (non-filter models)
- Basket Hanger
- Rack-type Basket Support
- Twin Baskets

PART #	DESCRIPTION	PRICE
--------	-------------	-------

FRYER ACCESSORIES

8030099	Basket, Full Size, SR42 & SR52 12-3/8 x 12-7/8 x 5-1/4	\$585
8030271	Basket, Twin Size, SR42 & SR52 5-7/8 x 12-5/8 x 6-5/8	\$400
8102793	Basket Hanger. SR42 & SR52 12-1/2 W x 3-1/2 H	\$280
8030132	Basket Support Rack, Full Pot 12-1/2 W x 13-3/4 D	\$280
8030278	Brush, L-Shaped Teflon 26-3/4" L x 1" Diameter	\$245
8030429	Brush, L-Shaped Tampico 21" L x 2" Diameter	\$195
	CASTERS - Set of Four	\$650
8030197	Clean-Out Rod — 27" Long	\$250
8239414	Cover, Stainless Steel, Full Pot 14-5/8 W x 19-3/8 D	\$565
8030059	Fish Scoop 8-1/8 W x 8-1/2 D w/ 17-3/8 Handle	\$290
8030446	Fish Skimmer, No Hooks 6" Square w/ Insulated Handle	\$280
2302884	Top Connecting Strip 2-1/4 W x 19-3/4 D x 1-5/8 H	\$350
8233696	Sediment Scoop	\$180

FRYMASTER & DEAN SPECIALTY PRODUCTS

AVAILABLE MODELS	PRODUCT DESCRIPTION	PRICE (\$)
OPEN POT FRYERS SPREADER CABINET, FOOD WARMER AND HOLDING PAN		
FQG30, FQE30, OCF30, H55, MJ50, MJ40, RE14, RE14TC, RE17, RE17TC	Spreader Cabinet - Fryer Match	\$2,405
1814E, MJCF, RE80	Spreader Cabinet - Fryer Match	\$3,185
FWH-1, FQE60	Food Warmer & Holding Pan — Includes heat lamp, cord & plug, and 12" x 20" x 2-1/2" stainless cafeteria style pan & screen.	\$1,810
FWH-1A	Food Warmer & Holding Pan — Includes heat lamp, cord & plug, and 13-1/2" x 17" x 8" scoop-type perforated pan.	\$1,980
Holding Pan Only	12" x 20" x 2-1/2" Stainless Cafeteria Style Pan & Screen	\$600
FWH-4	Food Warmer & 4" D Cafeteria Style Holding Pan With Scoop Type Grated Screen	\$1,940

AVAILABLE MODELS	PRODUCT DESCRIPTION	PRICE (\$)
TUBE FRYERS SPREADER CABINET, FOOD WARMER AND HOLDING PAN		
PR50, HD50,	15MC Spreader Cabinet	\$1,980
1814G, D60G, HD60, FQG60	20MC Spreader Cabinet	\$2,695
FWH-1	Food Warmer & Holding Pan — Includes heat lamp, cord & plug, and 12" x 20" x 2-1/2" stainless cafeteria style pan & screen.	\$1,810
FWH-1A	Food Warmer & Holding Pan — Includes heat lamp, cord & plug, and 13-1/2" x 17" x 8" scoop-type perforated pan.	\$1,980
Holding Pan Only	12" x 20" x 2-1/2" stainless cafeteria style pan & screen	\$600

MODEL NUMBER	PRODUCT DESCRIPTION	DIMENSIONS W" X D" X H"	SHIPPING WEIGHT LBS	PRICE (\$)
FRYMASTER CLEANING DISPOSAL CADDY				
CDC63	Specifically designed for disposal of boil-out solution	11-1/2" x 28-1/8" x 31-7/8"	30 lbs	\$2,635

NOTES:

- Spreader cabinets have a solid flat cover or optional 12" W x 20" D cutout.
- Food Warmers/Holding Pans are optional accessories used with Frymaster/Dean spreader cabinets.
- Casters — Add **\$650**.
- Any questions or pricing information other than the above should be referred to **Customer Service** .

FRYMASTER & DEAN PORTABLE FILTERS

MODEL NUMBER	PRODUCT DESCRIPTION	CAPACITY LBS	SHIPPING WEIGHT LBS	PRICE (\$)
FRYMASTER PORTABLE FILTERS				
PF50S	50-lb oil capacity, standard gravity drain	50 lbs	120 lbs	\$7,140
PF50R	50-lb oil capacity, reversible pump	50 lbs	120 lbs	\$7,140

NOTES:

- 4 GPM filter pump and 5' return hose included.
- Shipped with filter starter kit.
- Available voltage 120V-60 Hz 9 Amp.

PART NUMBER	PRODUCT DESCRIPTION	PRICE (\$)
FRYMASTER PORTABLE FILTER ACCESSORIES		
8235950	Crumb Tray (for PF50 only)	\$390

MODEL NUMBER	PRODUCT DESCRIPTION	CAPACITY LBS	SHIPPING WEIGHT LBS	PRICE (\$)
FRYMASTER PORTABLE FILTERS				
PF80S	80-lb oil capacity, standard gravity drain	80 lbs	120 lbs	\$7,930
PF80R	80-lb oil capacity, reversible pump	80 lbs	120 lbs	\$7,930
PF80LPS	80-lb oil capacity, standard gravity drain	80 lbs	147 lbs	\$7,930
PF80LPR	80-lb oil capacity, reversible pump	80 lbs	147 lbs	\$7,930
PF110S	110-lb oil capacity, standard gravity drain	110 lbs	125 lbs	\$8,125
PF110R	110-lb oil capacity, reversible pump	110 lbs	125 lbs	\$8,125

*PF80LPR low profile filters are also recommended for Frymaster and other fryers. R models can be used with any fryer because they have a reversible pump.

NOTES:

- 4 GPM filter pump and 5' return hose included.
- Shipped with Frymaster filter starter kit.
- Available voltage 120V-60 Hz 9 Amp.
- Any questions or pricing information other than the above should be referred to **Customer Service**.

MODEL NUMBER	PRODUCT DESCRIPTION	CAPACITY LBS	SHIPPING WEIGHT LBS	PRICE (\$)
FRYMASTER SHORTENING DISPOSAL UNITS				
PSDU50	50-lb oil capacity - fits under all Frymaster & Dean fryers except Dean single filtration models	50 lbs	62 lbs	\$2,545
PSDU100	100-lb oil capacity - fits under all Frymaster & Dean fryers including Dean single filtration models	100 lbs	80 lbs	\$3,300

NOTES:

- 9-5/8" drain height with cover open.
- Large 6", high-strength wheels provide easy transporting of oil.
- Any questions or pricing information other than the above should be referred to **Customer Service**.

PART NUMBER	PRODUCT DESCRIPTION	PRICE (\$)
SHORTENING DISPOSAL UNIT ACCESSORIES		
8262173	Hose, 48"	\$640

FILTER ACCESSORIES/SUPPLIES

PART NUMBER	ITEM	DESCRIPTION (INCHES) (WxDxH)	PRICE (\$)
FILTER ACCESSORIES			
8030072	Cone Holder	10" D	\$185
8030197	Clean-out Rod	26" L	\$250
8030059	Fish Scoop	8-1/8 "W x 8-1/2" D with 17-3/8" Handle	\$290
8030042	Filter Cones	10 Diameter — Box of 50	\$210
8030429	Fryer Brush, L-shaped Tampico	21" L, 2" D	\$195
8030278	Fryer Brush, L-shaped Teflon	26-3/4" L, 1"	\$245
8030002	Filter Powder	80, 1 oz. Pre-portioned Packs per Box	\$245
8030293	Gloves	Black, Safety	\$175
8030446	Skimmer	6" Square With Insulated Handle 13-5/8" L	\$280
8233696	Sediment Scoop	Large	\$180

PART NUMBER	BUILT-IN FILTER	PAPER SIZE (INCHES) (W X D)	PACKAGING	SHIPPING WEIGHT	PRICE (\$)
8030003	Filter Magic Filters before 5/90	12-1/2 x 17-3/4	Box of 100 sheets	3 lbs.	\$290
8030074	80-lb, MJCF Fryer Filters before 8/90	17-1/2 x 19-1/4	Box of 100 envelopes	8 lbs.	\$695
8030289	50/60 Series Fryers, UFF Equipped**	22 x 34	Box of 100 sheets	8 lbs.	\$470
8030170	All Filter Magic, Footprint, and Footprint Pro filters after 5/90	19-1/2 x 27-1/2	Box of 100 sheets	4 lbs.	\$290
8030345	50/60/80 Series Fryers, SUFF Equipped*	17 x 33-1/4	Box of 100 sheets	4 lbs.	\$470
8030303	80/100 Series Fryers, UFF Equipped**	26 x 34	Box of 100 sheets	4 lbs.	\$470
8030317	50 Series Fryers, SUFF-Equipped* 2001 & older	8-1/4 x 25-3/4	Box of 100 sheets	3 lbs.	\$290
8030445	FilterQuick (gas & electric) OCF30 (gas & electric)	16-1/2" x 25-1/2"	Box of 100 sheets	4 lbs.	\$290

PART NUMBER	PORTABLE FILTER	PAPER SIZE (INCHES) (W X D)	PACKAGING	SHIPPING WEIGHT	PRICE (\$)
8030170	All PF Portable Filters	19-1/2 x 27-1/2	Box of 100 sheets	4 lbs.	\$290









NOTES:

- Frymaster/Dean filter paper is specifically designed for each Frymaster/Dean filter system. It is specially woven to allow the free flow of oil, while containing the food particles, sediment and other contaminants drawn by the filter powder. For best results, use only genuine Frymaster/Dean filter paper. Use of other than approved paper could void warranty.
- Filter powder is a food-grade filtering agent designed for use with Frymaster's built-in and portable filtering systems. It is specially formulated to remove foreign particles, sediment and other contaminants from the oil, leaving it freshened and extending its useful life.
- Any questions or pricing information other than above should be referred to **Customer Service**.

*SUFF-Equipped systems are single frypots with built-in filtration only.

**UFF-Equipped systems are multi-battered frypots with built-in filtration only.

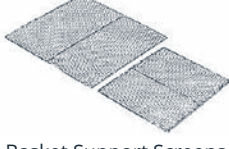



GAS FRYER ACCESSORIES

	PART NUMBER	DESCRIPTION	SIZE (INCHES) (WxDxH)	APPLICABLE MODELS	PRICE
 Full Size Basket	8030017	Basket, Full Size	17-1/2 x 16-3/4 x 6	MJCF, HD60G, D60G, SR62	\$610
	8030099	Basket, Full Size (Cannot Be Used With Basket Lifts)	12-3/8 x 12-7/8 X 5-1/4	H55, MJ50, GF40, OCF30, HD50G, PRG50, SR42, SR52	\$585
 Triplet Basket	8030015	Basket, Full Size (Cannot Be Used With Basket Lifts)	11-3/4 x 14 x 4-5/8	MJ40, GF14	\$585
	8030435	Basket, Full Size	17-1/2 x 12-7/8 x 6-1/8	1814	\$570
	8030148	Basket, Full Size	17-1/2 x 16-3/4 x 5-7/8	LHD65	\$610
	8030357	Basket, Triplet Size	4-1/2 x 13-1/4 x 6	H55, MJ50, GF40, HD50G, FQ60, PRG50	\$400
 Twin Baskets	8030023	Basket, Triplet Size	5-3/4 x 17-1/8 x 6-1/8	MJCF	\$455
	8030438	Basket, Triplet Size	4-1/4 x 13-1/4 x 5-1/2	OCF30	\$400
	8030427	Basket, Triplet Size	5-5/8 x 15-7/8 x 7-1/4	HD60G, LHD65, D60G, SR62	\$425
	8030271	Basket, Twin Size	5-7/8 x 12-5/8 x 6-5/8	H55, MJ50, MJ40, GF40, GF14, OCF30, 1814, HD50G, ESG35T, PRG50, SR42, SR52	\$400
 Basket Hanger	8030024	Basket, Twin Size	8-3/4 x 16-3/4 x 6	MJCF	\$545
	8030304	Basket, Twin Size	8-3/4 x 16-3/4 x 6	HD60G, LHD65	\$400
 Basket Hanger Over the Flue	8030436	Basket, Chicken	17-3/4 x 12-1/4 x 11	1814	\$990
	8030437	Basket, Dual	8 x 12-5/8 x 7	1814	\$420
	8030357	Basket, Quad	4-1/2 x 13-1/4 x 6	1814	\$400
 Basket Support Racks	8102793	Basket Hanger	12-1/2 W x 3-1/2 H	H55, MJ50, MJ40, GF40, GF14, ESG35T, SR42, SR52	\$280
	2601808	Basket Hanger, Flue Mounted		MJ50, MJ40	\$245
	8102794	Basket Hanger	17-3/8 W x 3-1/2 H	MJCF, RE80, SR62	\$280
	2308165	Basket Hanger	15-3/8 W x 5 H	OCF30 single frypot	\$280
	2307495	Basket Hanger	31 W x 5 H	FQ & OCF30 two frypot fryer/four frypot fryer (2)	\$430
 Basket Support Screens	2307497	Basket Hanger	46-1/2 W x 5 H	FQ & OCF30 three frypot fryer	\$635
	8237770	Basket Hanger — Over The Flue	20 W x 8-1/2 H	11814 single frypot	\$280
	8237771	Basket Hanger — Over The Flue	39-3/4 W x 8-1/2 H	21814 two frypot fryer	\$430
	2101595	Basket Hanger — Over The Flue	15-3/8 W x 6-5/8 H	HD50G, PRG50 (singles) Call Customer Service for batteries	\$280
 Basket Support Screen with handle	2102737	Basket Hanger — Over The Flue	20 W x 6-5/8 H	HD60G, D60G (singles) Call Customer Service for batteries	\$280
	8235859	Basket Hanger With Flue Deflector	20 W x 7 H	LHD65	\$280
	8030132	Basket Support Rack Type — Full Pot	12-1/2 W x 13-3/4 D	H55, MJ50, GF40	\$280
	8030032	Basket Support Rack Type — Full Pot	11-1/2 W x 14-5/8 D	MJ40, GF14	\$280
	8030137	Basket Support Rack Type — Full Pot	17-1/2 W x 17-1/2 D	MJCF	\$280
	8030375	Basket Support Rack Type — Full Pot	11-7/8 W x 13-1/2 D	OCF30	\$290
	8030372	Basket Support Rack Type— Split Pot	5-7/8 W x 13-1/2 D	OCF30	\$250
	8030133	Basket Support Rack Type — Split Pot	6 W x 14 D	H55, MJ50	\$250
	8030380	Basket Support Rack Type — Full Pot	13-5/8 W x 18 D	1814	\$280

NOTES:

- Any questions or pricing information other than above should be referred to **Customer Service** .

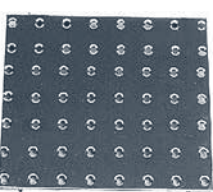





GAS FRYER ACCESSORIES

	PART NUMBER	DESCRIPTION	SIZE (INCHES) (WxDxH)	APPLICABLE MODELS	PRICE
 L-shaped Brush Tampico	8102235	Basket Support Rack Type	17-3/8 W x 17-5/8 D	LHD65, HD60G, D60G, SR62	\$405
	8030273	Basket Support Rack Type	13-1/2 W x 13-1/4 D	HD50G, PRG50, SR42, SR52	\$280
 L-shaped Brush Teflon	8030442	Basket Support Rack Type	13-1/2 W x 11-1/4 D	ESG35T	\$280
	8030277	Basket Support Rack, Fine Mesh	13-1/2 W x 13-1/4 D	HD50G, PRG50, SR42, SR52	\$340
	8030149	Basket Support Rack, Fine Mesh	17 W x 17 D	LHD65, HD60G, D60G, SR62	\$400
	8030136	Basket Support Screen Type With Handle - Full Pot Only	12-1/2 W x 13-3/4 D	H55, MJ50, GF40	\$340
 Casters	8030037	Basket Support Screen Type Full Pot Only	11-1/2 W x 14-5/8 D	MJ40, GF14	\$330
	8030138	Basket Support Screen Type With Handle - Full Pot Only	17-1/2 W x 18-1/2 D	MJCF	\$340
	8103066	L-Basket Support Rack	17-5/8 W x 17-5/8 D	LHD65	\$470
	8030429	Brush L-Shaped, Tampico	21 Long, 2 Diameter	All Models	\$195
 Chicken/Fish Plate	8030278	Brush L-Shaped, Teflon	26-3/4 Long, 1 Diameter	All Models	\$245
		Casters - Set Of Four, Call Customer Service to Specify Fryer Models		All Models	\$650
 Clean-out Rod	8230619	Chicken/Fish Plate - Full Pot (Not Available For Split Pot)	12-3/8 W x 14 D	H55, MJ50, GF40	\$735
	8233048	Chicken/Fish Plate - Full Pot	11-3/4 W x 14-3/4 D	MJ40, GF14	\$705
	8230368	Chicken/Fish Plate - Full Pot	17-7/8 W x 18 5/8 D	MJCF	\$905
	8238066	Chicken/Fish Plate - Full Pot	12 W x 13-3/8 D	FQ, OCF30	\$725
	2208966	Chicken/Fish Plate - Full Pot	18 W x 13-5/8 D	1814	\$790
	2208963	Chicken/Fish Tray - Full Pot	13-5/8 W x 13-1/2 D	HD50G	\$725
	8233947	Chicken/Fish Tray - Full Pot	16-1/2 x 16-1/2 x 11	HD60G, D60G	\$810
	8236895	Chicken/Fish Tray	13-1/2 x 13-1/2 x 11	PRG50	\$400
	8030197	Clean - Out Rod	27 Long	All Models (except FQ)	\$250
	8030388	Clean - Out Rod	27-1/2 Long	FQ	\$250
 Covers	8239416	Cover - Split Pot		H55	\$340
	8238898	Cover - Split Pot		OCF30G	\$340
 Crumb Scoop	8239413	Cover - Stainless Steel	20-3/8 W x 28 D	MJCF	\$565
	8239426	Cover - Stainless Steel Full Pot, with basket lifts	15-1/8 W x 20-1/4 D	H55, MJ50, MJ40, GF40, GF14	\$565
	8238897	Cover - Stainless Steel - Full Pot	14-5/8 W x 21 D	FQ, OCF30	\$565
	1081872	Cover - Stainless Steel - Full Pot	21-3/8 W x 19-1/2 D	11814	\$565
	1061637	Cover - Stainless Steel - Full Pot	13-1/2 W x 21-3/8 D	HD50G, ESG35T, PRG50, SR42, SR52	\$565
	1061479	Cover - Stainless Steel without Basket Lifts	23-3/8 W x 19-3/4 D	HD60G, D60G, SR62	\$665
	1062734	Cover - Stainless Steel w/Basket Lifts	14-1/4 W x 20-1/2 D	HD50G, PRG50	\$530
	1062773	Cover - Stainless Steel w/Basket Lifts	18 W x 22-5/8 D	HD60G, D60G	\$665
	8233938	Crumb Scoop Cold Zone	1-1/4 W x 6-1/2 D x 22-3/4 Long	All Open Pots	\$280

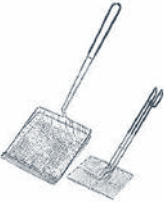
NOTES:

- Any questions or pricing information other than above should be referred to **Customer Service**.

GAS FRYER ACCESSORIES

	PART NUMBER	DESCRIPTION	SIZE (INCHES) (WxDxH)	APPLICABLE MODELS	PRICE
 <p>Fish Scoop, Left Fish Skimmer, Right</p>	8238066	Fish Plate	12 x 13-3/8 x 3/8	FQ, OCF	\$725
	2400916	Fish Plate, Wet-battered		1814G	\$795
	8030059	Fish Scoop	8-1/8 W x 8-1/2 D with 17-3/8 handle	All Models	\$290
 <p>Flue Deflector</p>	8030446	Fish Skimmer	6 square with 13-5/8 insulated handle, no hooks	All Models	\$280
	9103557	Flue Deflector	12-1/2 W x 6-7/8 H	H55, MJ50, MJ40 GF40, GF14	\$300
 <p>Legs</p>	9103185	Flue Deflector	14-1/2 W x 8 H	MJCF	\$300
	8235801	Flue Deflector	20 W x 9-1/2 H	LHD65	\$300
	2003651	Flue Deflector	15-3/8 W x 3 H	PRG50	\$245
	2003649	Flue Deflector	18-3/8 W x 3 H	D60G	\$330
 <p>Quick Disconnect</p>		Foam Deck Basket Banger		1814, OCF, FQ, H55, HD50G, HD60G, MJ50	\$455/ FRYPOT
	8030293	Gloves, Black Safety		All Models	\$175
		Legs – Set of Four – Nickel Call Customer Service To Specify Fryer Models	6 H		\$650
 <p>Sediment Tray Full Pot</p>		Legs – Set of Four – Stainless Steel Call Customer Service To Specify Fryer Models	6 H		\$650
		Legs – Set of Four – Stainless Steel Call Customer Service To Specify Fryer Models	8-1/2 H	H55	\$650
	1086895	Stainless Steel Mobile JIB Container		FQG30	\$860
 <p>Sediment Tray MJCF Gas Fryer</p>	8061698	Quick Disconnect with 1" Gas Line Systems Only	36 Long	H55, MJ50, MJ40, MJCF, 1814, OCF30, LHD65	\$1,255
	8061699	Quick Disconnect with 1" Gas Line Systems Only	48 Long	H55, MJ50, MJ40, MJCF, 1814, OCF30, LHD65	\$1,345
	8061701	Quick Disconnect with 3/4" Gas Line Single Units	36 Long	H55, MJ50, MJ40 GF40, GF14, 1814, OCF30G, LHD65	\$1,015
	8061700	Quick Disconnect With 3/4" Gas Line Single Units	48 Long	H55, MJ50, MJ40 GF40, GF14, 1814, OCF30G, LHD65	\$1,105
	8030103	Sediment Tray — Full Pot	12-1/2 x 14 x 6-1/2	H55, MJ50, GF40	\$955
	8030188	Sediment Tray — Full Pot	11-1/4 x 14-1/2 x 4-1/8	MJ40, GF14	\$790
	8030187	Sediment Tray — Full Pot	17-1/2 x 18-1/2 x 4-3/8	MJCF	\$950
	8030511	Sediment Tray — Full Pot	11-7/8 x 13-3/8 x 6-1/2	OCF30	\$985
	8030107L	Sediment Tray — Split Pot Left	5-7/8 x 14 x 6-1/2	H55-2	\$725
	8030108R	Sediment Tray — Split Pot Right	5-7/8 x 14 x 6-1/2	H55-2	\$725
	1064136	Sediment Tray	13-1/2 W x 13-3/4 D	HD50G, PRG50	\$985
	1062631	Sediment Tray	17-3/4 W x 17-1/8 D	HD60G, D60G, SR62	\$1,160
	1086187	Sediment Tray	17-3/4 W x 13-5/8 D	1814E	\$1,160

NOTES:

- Any questions or pricing information other than above should be referred to Customer Service.

GAS FRYER ACCESSORIES



Splash Shield



Top Connecting Strip

PART NUMBER	DESCRIPTION	SIZE (INCHES) (WxDxH)	APPLICABLE MODELS	PRICE
8236559	Splash Shield	20 D x 6-1/4 H	H55, MJ50, MJ40	\$565
8235978	Splash Shield	30-3/8 D x 13-1/8 H	MJCF	\$565
8237619	Splash Shield	21-3/8 D x 7-7/8 H	11814	\$565
8238224	Splash Shield, Side	19-1/2 D x 11-3/4 H	FQ, OCF30	\$565
8233225	Splash Shield	21-1/2 D x 13 H	HD50G, PRG50	\$340
8235744	Splash Shield	23 1/2D x 14H	HD60G, D60G	\$340
8235789	Splash Shield	18D x 14H	LHD65	\$405
2109291	Top Connecting Strip	2-1/4 W x 20-1/2 D	H55, MJ50, MJ40	\$350
9102662	Top Connecting Strip	2-1/8 W x 28-1/8 x D x 1-3/4 W	MJCF	\$405
2102681	Top Connecting Strip	2 W x 21-3/8 D	1814G, HD50, PRG50, SR42G, SR52	\$350
2105086	Top Connecting Strip	2 W x 23-5/8 D	HD60G, D60G	\$350
8235810	Top Connecting Strip	1-7/8 W x 20-3/4 D	OCF30G	\$350
9102285	Top Connecting Strip	2-1/8 x 20-5/8 x 1-3/4	GF14, GF40	\$350

NOTES:

- Any questions or pricing information other than above should be referred to **Customer Service**.

ELECTRIC FRYER ACCESSORIES



Full Size Basket



Triplet Basket



Twin Baskets



Basket Hanger



Basket Support Screens



Basket Support Screen with Handle



L-Shaped Brush, Tampico



L-shaped Brush Teflon



Casters



Chicken/Fish Plate

PART NUMBER	DESCRIPTION	SIZE (INCHES) (WxDxH)	APPLICABLE MODELS	PRICE
8030099	Basket, Full Size (Cannot Be Used with Basket Lifts)	12-3/8 x 12-7/8 x 5-1/4	RE14, RE17, RE14TC, RE17TC, OCF30, SR14E	\$585
8030148	Basket, Full Size	16-3/4 x 17-1/2 x 5-3/4	RE80	\$610
8030435	Basket, Full Size	17-1/2 x 12-7/8 x 6-1/8	1814	\$570
8030427	Basket, Triplet Size	5-5/8 x 16 x 7	RE80	\$425
8030357	Basket, Triplet Size	4-1/2 x 13-1/4 x 6	RE14, RE17	\$400
8030438	Basket, Triplet Size	4-1/4 x 13-1/4 x 5-1/2	OCF30	\$400
8030271	Basket, Twin Size	5-7/8 x 12-5/8 x 6-5/8	RE14, RE17, RE14TC, RE17TC, OCF30, SR14E, 1814E	\$400
8030304	Basket, Twin Size	8-3/4 x 16-3/4 x 6	RE80	\$400
8030306	Basket, Twin Size	7-5/8 x 15-7/8 x 7-3/8	RE80 w/BL	\$425
8030441	Basket, Chicken	17-3/4 x 12-3/4 x 11	1814	\$990
8030437	Basket, Dual	8 x 12-5/8 x 7	1814	\$420
8030357	Basket, Quad	4-1/2 x 13-1/4 x 6	1814	\$400
8102793	Basket Hanger, Wire	12-1/2 W x 3-1/2 H	RE14, RE17, RE14TC, RE17TC, SR14E	\$280
2308165	Basket Hanger	15-3/8 W x 5 H	OCF30 Single Frypot	\$280
2307495	Basket Hanger	31 W x 5 H	FQ & OCF30 Two Frypots / Four Frypots (2)	\$430
2307497	Basket Hanger	46-1/2 W x 5 H	FQ & OCF30 Three Frypots	\$635
8102794	Basket Hanger	17-3/8 W x 3-1/2 H	RE80	\$280
2304318	Basket Hanger — Over The Flue	19-7/8 W x 5-1/4 H	11814E Single Frypot	\$280
2308464	Basket Hanger — Over The Flue	39-3/4 W x 5-1/4 H	21814E Two Frypot Fryer	\$430
8030136	Basket Support Screen Type With Handle Full Pot (Not Available For Split Pot)	12-1/2 W x 13-3/4 D	RE14, RE17, RE14TC, RE17TC, OCF30 Fryers	\$340
8030429	Brush L-Shaped, Tampico	21 Long, 2 Diameter	All Models	\$195
8030278	Brush L-Shaped, Teflon	26-3/4 Long, 1 Diameter	All Models	\$245
	Casters, Set Of Four — Call Customer Service To Specify Fryer Models		RE14, RE17, RE14TC, RE17TC, RE80, 11814E	\$650
8238065	Chicken/Fish Plate — Full Pot (Not Available For Split Pot)	13-1/2 W x 13-1/8 D	FQ, OCF30	\$725
2208964	Chicken/Fish Plate — Full Pot (Not Available For Split Pot)	13-5/8 W x 14-1/4 D	RE14, RE17, RE14TC, RE17TC	\$725
2208962	Chicken/Fish Plate — Full Pot	17 W x 13-1/2 D	1814E	\$725
8238861	Chicken/Fish Tray — Full Pot	13 W x 13-1/2 Dx 11H	FQ	\$725
8233947	Chicken/Fish Tray	16-1/2 x 16-1/2 x 11	RE80	\$810

NOTES:

- Any questions or pricing information other than above should be referred to Customer Service.

Tel: 905-624-1419 • 888-442-7526

Fax: 905-624-1851 • 800-361-2724

For more information, visit www.garlandcanada.ca

ELECTRIC FRYER ACCESSORIES

	PART NUMBER	DESCRIPTION	SIZE (INCHES) (WxDxH)	APPLICABLE MODELS	PRICE
	8030197	Clean-Out Rod	27 Long	All Models (except FQ)	\$250
Clean-out Rod	8030388	Clean-Out Rod	27-1/2 Long	FQ	\$250
	1080220	Cover	20 x 22-1/4 x 1-1/2 includes handle	RE80	\$675
Covers	8239414	Cover, Stainless Steel — Full Pot	14-5/8 W x 19-3/8 D	RE14, RE17, RE14TC, RE17TC, SR14E	\$565
	8238899	Cover, Stainless Steel — Full Pot	14-3/8 W x 19-1/2 D	OCF30	\$565
Fish Scoop, Left Fish Skimmer, Right	8239415	Cover, Stainless Steel — Split Pot	7-1/2 W x 19-3/8 D	OCF30	\$340
	8239402	Cover, Stainless Steel — Full Pot	19 W x 19-3/8 D	1814E	\$565
Legs	8238065	Fish Plate	13 x 13-1/2 x 4-1/2	FQ, OCF	\$725
	8030059	Fish Scoop	8-1/8 W x 8-1/2 D with 17-3/8 handle	All Models	\$290
Rack Type Basket Support	8030446	Fish Skimmer	6 square with 13-5/8 insulated handle	All Models	\$280
		Foam Deck Basket Banger		OCF, RE, RE80	\$455/ FRYPOT
Splash Shield	8030293	Gloves, Black Safety		All Models	\$175
		Legs – Set Of Four – Stainless Steel Call Customer Service to Specify Fryer Models	8-1/2 H	RE14, RE17, RE14TC, RE17TC, RE80, 11814E	\$650
Top Connecting Strip	1086895	Stainless Steel Mobile JIB Container		FQE30	\$860
	8030132	Rack Type Basket Support — Full Pot	12-1/2 W x 13-3/4 D	RE14, RE17, RE14TC, RE17TC, OCF30 Fryers	\$280
	8030106	Rack Type Basket Support — Split Pot	5-3/4 W x 13-1/2 D	RE14-2, RE17-2, RE14-2TC, RE17-2TC, OCF Fryers	\$250
	8030380	Rack Type Basket Support — Full Pot	13-5/8 W x 18 D	1814E	\$280
	8030387	Rack Type Basket Support, Fine Mesh	17-3/8 W x 17-5/8 D	RE80	\$340
	8030358	Sediment Tray — Full Pot	10-1/2 x 11-5/8 x 4	RE14, RE17, RE14TC, RE17TC	\$955
	8030360L	Sediment Tray — Split Pot Left	4-5/8 x 13-3/4 x 4	RE14-2, RE17-2, RE14-2TC, RE17-2TC	\$725
	8030359R	Sediment Tray — Split Pot Right	4-5/8 x 13-3/4 x 4	RE14-2, RE17-2, RE14-2TC, RE17-2TC	\$725
	1086187	Sediment Tray	17-3/4 W x 13-5/8 D	11814E	\$1,160
	8236559	Splash Shield	20 D x 6-1/8 H	RE14, RE17, RE14TC, RE17TC	\$565
	8238155	Splash Shield	20-5/8 D x 6 H	1814E	\$565
	8238224	Splash Shield, Side	19-1/2 D x 11-3/4 H	FQ, OCF30	\$565
	8235810	Top Connecting Strip	1-7/8 W x 21 D	RE14, RE17, RE14TC, RE17TC	\$350
	2305382	Top Connecting Strip	2 W ax 23-3/4 D	RE80	\$380
	8238190	Top Connecting Strip	2-3/4 W x 21 D	11814E	\$350

NOTES:

- Any questions or pricing information other than above should be referred to **Customer Service**.

FRYMASTER/DEAN PRODUCT SUMMARY

Available Accessories		Electronic Ignition						Split Fry Pot		Basket Lifts		Casters		Legs	
Cabinet Finish		Stainless Steel FryPot, Doors and Cabinet Ends						Aluminized Sides		Aluminized Sides		Aluminized Sides		Aluminized Sides	
External Oil		Rear		Front		Rear		Front		Rear		Front		Rear	
FILTRATION		Maximum Number of Fryers w/Filtration		Single Unit Available w/Filtration		Filter Prefix / Suffix		Maximum Number of Fryers w/Filtration		Single Unit Available w/Filtration		Filter Prefix / Suffix		Maximum Number of Fryers w/Filtration	
CONTROLLERS		FQ4000 EasyTouch		SMART 4U LANE 3000		3010		3000		CM 3.5		DIGITAL		THERMOTRON	
Production/hr. Full Fry Pot French Fries		Kw/hr		Electric		Production/hr. Full Fry Pot French Fries		Btu/hr		Gas		Pot		lbs(Liters) Oil Capacity	
Energy Star		Energy Star		Energy Star		Energy Star		Energy Star		Energy Star		Energy Star		Energy Star	
DEAN Frymaster		FilterQuick 30		FilterQuick 60		1814		OCF30		ESG35T		LHD65		HD50	
		HD60		H55		MJ40		MJ50		MJCF		GF14		GF40	
		RE14TC		RE17TC		RE14									

Frymaster, LLC, whose policy is one of constant improvement, reserves the right to amend specifications without prior notice.

Tel: 905-624-1419 • 888-442-7526

Fax: 905-624-1851 • 800-361-2724

FRYER MODEL GUIDE

BUILT - IN FILTRATION	# OF FRYERS	# OF SPLIT VATS
FPP	1	-2 = 1 split vat
FP	2	-4 = 2 split vats
FM	3	-6 = 3 split vats
FMP	4	-8 = 4 split vats
CF	5	-10 = 5 split vats
SCF	6	

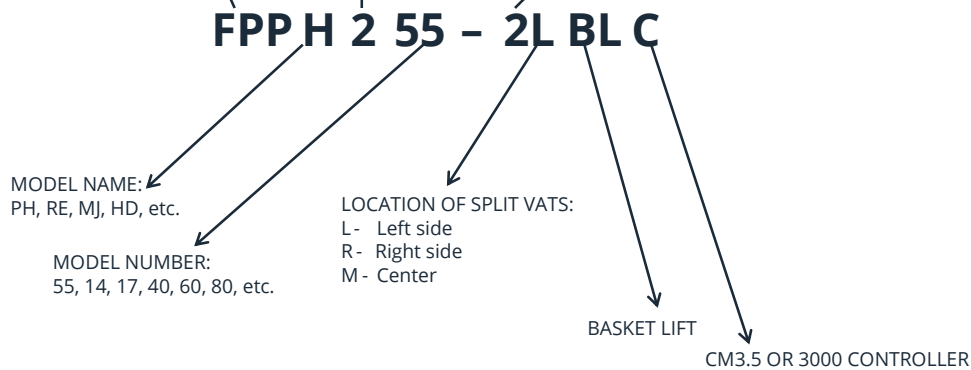

MODELS	DESCRIPTION
--------	-------------

COMMON MODEL NUMBERS AND DESCRIPTIONS

21814NF	2 (# of frypots) 1814 (model name) N (natural gas) F (built-in filter)
RE117	RE (model name) 1 (# of frypots) 17 (model #)
FPRE217	FP (built-in filter) RE (model name) 2 (# of frypots) 17 (model #)
FMRE214BLC	FM (built-in filter with spreader) RE (model name) 2 (# of frypots) 14 (model #) BL (basket lifts) C (CM3.5 controller)
FPRE217-4C	FP (built-in filter) RE (model name) 2 (# of frypots) 17 (model #) -4 (2 split frypots) C (CM3.5 controller)
FPEL314CA	FPEL (model name) 3 (# of frypots) 14 (model #) C (3000 controller) A (auto top-off)
FPGL230CA	FPGL (model name) 2 (# of frypots) 30 (model #) C (3000 controller) A (auto top-off)
FPGL230-2RBLCA	FPGL (model name) 2 (# of frypots) 30 (model #) -2 (1 split frypot) R (split on right) BL (basket lifts) C (3000 controller) A (auto top-off)
PH155C	PH (model name) 1 (# of frypots) 55 (model #)
FPH155	FP (built-in filter) H (model name) 1 (# of frypots) 55 (model #)
FPPH255C	FP (built-in filter) P (pro series cabinet) H (model name) 2 (# of frypots) 55 (model #) C (CM3.5 controller)
FPPH255-2RC	FPP (built-in filter) H (model name) 2 (# of frypots) 55 (model #) -2 (1 split frypot) R (split is on right) C (CM3.5 controller)
MJ150	MJ (model name) 1 (# of frypots) 50 (model #)
SCFHD260GNC	SCF (built-in filter) HD (model name) 2 (# of frypots) 60 (model #) G (gas) N (natural gas) C (CM3.5 controller)
SR142GN	SR (model name) 1 (# of frypots) 42 (model #) G (gas) N (natural gas)
4FQG30U	4 (# of fryers) FQ (model name) G (gas) 30 (model number) U (open pot)

WHAT IS COVERED

This warranty covers all defects in workmanship and material in all commercial cooking appliances and computer/controller equipment manufactured by Frymaster and sold within the domestic United States, except as excluded below.

WHO IS COVERED

This warranty covers only the original purchaser of Frymaster or Dean commercial cooking appliances and computer/controller equipment. This warranty is not transferable. You must have your original sales receipt for warranty coverage.

WHAT WE WILL DO

We will repair or replace the defective appliance, component or part. Such repair or replacement will be at the expense of Frymaster except that travel over 100 miles or two hours, overtime and holiday charges will be at the expense of the purchaser.

REPLACEMENT PARTS

- Parts, 90 days, no labor
- Stainless steel frypots, 1 year, 90 days labor
- Computers, 1 year, no labor

HOW TO GET SERVICE

Contact our Authorized Service Agent to obtain warranty service. To find the name and location of the nearest ASA call your dealer, or call the Frymaster Service Hotline, 1-800-551-8633. You can also go to the Frymaster website, www.frymaster.com, click on Service, click on Locator, key in zip code and it will give you the ASA for that zip code. When calling for service, please furnish the model number, serial number, series code number, voltage of your appliance, and a description of the problem. You must keep your sales receipt for proof of your date of purchase.

	FRYPOT	FRYPOT & ASSEMBLY	CONTROLLERS	ALL OTHER PARTS
GAS				
FilterQuick 30 Gas	N/A	7 Years: Parts & Labor	1 Year: Parts & Labor 2nd Year: Parts Only	1 Year: Parts & Labor 2nd Year: Parts Only
FilterQuick 60 Gas	1st Year: Parts & Labor 2nd - 10th Years: Part Only	N/A	1 Year: Parts & Labor	1 Year: Parts & Labor
OCF30 Gas	N/A	7 Years: Parts & Labor	1 Year: Parts & Labor 2nd Year: Parts Only	1 Year: Parts & Labor 2nd Year: Parts Only
H55	N/A	7 Years: Parts & Labor	1 Year: Parts & Labor	1 Year: Parts & Labor
1814 Gas	1st Year: Parts & Labor 2nd - 10th Years: Part Only	N/A	1 Year: Parts & Labor	1 Year: Parts & Labor
MJ40/MJ50/MJCF	4th Year-Lifetime: Part Only	1st Year: Parts & Labor 2nd & 3rd Year: Parts Only	1 Year: Parts & Labor	1 Year: Parts & Labor
GF14/GF40	1st Year: Parts & Labor 2nd - 5th Years: Part Only	N/A	N/A	1 Year: Parts & Labor
HD50/60	1st Year: Parts & Labor 2nd - 10th Years: Part Only	N/A	1 Year: Parts & Labor	1 Year: Parts & Labor
LHD65	1st Year: Parts & Labor 2nd - 10th Years: Part Only	N/A	1 Year: Parts & Labor	1 Year: Parts & Labor
D60	1st Year: Parts & Labor 2nd - 10th Years: Part Only	N/A	1 Year: Parts & Labor	1 Year: Parts & Labor
PRG50T	1st Year: Parts & Labor 2nd - 10th Years: Part Only	N/A	N/A	1 Year: Parts & Labor
SR42/52/62	5 Years: Pro-Rated*	N/A	N/A	1 Year: Parts & Labor
ESG35T	5 Years: Pro-Rated*	N/A	N/A	1 Year: Parts & Labor

* 2nd year customer pays labor, freight and 20% of current frypot list price
 3rd year customer pays labor, freight and 40% of current frypot list price
 4th year customer pays labor, freight and 60% of current frypot list price
 5th year customer pays labor, freight and 80% of current frypot list price

FRYMASTER & DEAN FACTORY WARRANTY

	FRYPOT	FRYPOT & ASSEMBLY	CONTROLLERS	ALL OTHER PARTS
ELECTRIC				
FilterQuick 30 Electric	1st Year: Parts And Labor 2nd Year - Lifetime: Part Only	N/A	1 Year: Parts & Labor 2nd Year: Parts Only	1 Year: Parts & Labor 2nd Year: Parts Only
FilterQuick 60 Electric	1st Year: Parts And Labor 2nd Year - Lifetime: Part Only	N/A	1 Year: Parts & Labor 2nd Year: Parts Only	1 Year: Parts & Labor 2nd Year: Parts Only
OCF30 Electric	1st Year: Parts And Labor 2nd Year - Lifetime: Part Only	N/A	1 Year: Parts & Labor 2nd Year: Parts Only	1 Year: Parts & Labor 2nd Year: Parts Only
1814E	1st Year: Parts And Labor 2nd Year - Lifetime: Part Only	N/A	1 Year: Parts & Labor	1 Year: Parts & Labor
RETC14/17	1st Year: Parts And Labor 2nd Year - Lifetime: Part Only	N/A	1 Year: Parts & Labor	1 Year: Parts & Labor
RE14/17	1st Year: Parts And Labor 2nd Year - Lifetime: Part Only	N/A	1 Year: Parts & Labor	1 Year: Parts & Labor
RE80	1st Year: Parts And Labor 2nd Year - Lifetime: Part Only	N/A	1 Year: Parts & Labor	1 Year: Parts & Labor

	COOK POT & ASSEMBLY	COOK POT	ALL OTHER PARTS
OTHER PRODUCTS			
Shortening Disposal Unit			90 Days: Parts & Labor 91 Days - 1 Year: Pump Part Only
CDC63			90 Days: Parts & Labor
Portable Filters			1 Year: Parts & Labor

WHAT THIS WARRANTY DOES NOT COVER

THE WARRANTIES PROVIDED BY FRYMASTER, LLC DO NOT APPLY IN THE FOLLOWING INSTANCES:

- Damage due to misuse, abuse, alteration, or accident.
- Improper or unauthorized repair.
- Failure to follow installation procedures, operation instructions and/or scheduled maintenance procedures as prescribed in your Frymaster or Dean Service and Owner's Manual.
- Damage in shipment.
- Removal, alteration, or obliteration of the rating plate.
- Changes in adjustment and calibrations after thirty (30) days from equipment installation date.
- Failure to program computer appliances in accordance with programming procedures prescribed in your Frymaster or Dean Service and Owner's Manual.
- Equipment exported to foreign countries.
- Normal maintenance items such as electric bulbs, fuses, gaskets, o-rings, interior and exterior finishes.
- Travel over 100 miles or two hours, overtime or holiday charges, all of which must be paid for by the purchaser.
- Consequential damages (the cost of repairing other property which is damaged), loss of time, profits, use or any other non-fryer related incidental damages of any kind.

GENERAL EXCLUSIONS

Warranty protection is only offered for fryers installed in accordance with the procedures described in the Frymaster or Dean Service and Owner's Manual.

There are no implied warranties of merchantability of fitness for any particular use or purpose. This warranty is the only and complete statement with respect to warranties of your commercial cooking appliances and computer/controller equipment manufactured by Frymaster. There are no other documents or oral statements for which Frymaster will be responsible.

LIMITED WARRANTY

Garland Canada (GC) warrants this product to be free from defects in material and workmanship for a period of one (1) year from the date the product is installed or twenty-four (24) months from the date of shipment from our facility, **whichever comes first**, and sold within Canada.

During the warranty period, GC shall, at GC's option, repair or replace parts determined by GC to be defective in material or workmanship, and with respect to services, shall re-perform any defective portion of said services. The foregoing shall be the sole obligation of GC under this Limited Warranty with respect to the equipment, products and services. With respect to equipment, materials, parts and Accessories manufactured by others, GC's sole obligation shall be to use reasonable efforts to obtain the full benefit of the manufacturer's warranties. GC shall have no liability, whether in contract, tort, negligence, or otherwise, with respect to non-GC manufactured products.

HOW LONG THE COVERAGE LASTS

MJH50/MJH55 High Efficiency models are warranted to be free of defects which would cause shortening leaks due to weld failures for five (5) years, parts and labour on frypot assembly. The combustion chamber, which consists of the infrared burners and the structural components to mount the burners, are also warranted against defective material or workmanship for seven (7) years, parts and labour.

Stainless steel frypots on all other fryers, except as noted below, are warranted to be free from defects which would cause shortening leaks due to weld failures for the period of one (1) year parts and labour. Stainless frypots for models listed below are warranted for the length of time indicated, except that after one (1) year the warranty is limited to replacement parts. Warranty is deemed to be twelve (12) months from date of purchase or twenty-four (24) months from shipment from GC.

Five (5) years = GF14, GF40, MJ50, MJ40, Pasta Systems (gas and electric).

One (1) year = All cold rolled.

Fenwal thermostats are warranted for two (2) years except after one (1) year, the warranty is limited to replacement parts. All other part components are warranted for one (1) year from the date of purchase (parts and labour). The shortening disposal unit is warranted for ninety (90) days parts only. In addition, the pump is warranted for one (1) year, parts only.

For MJH50/MJH55, MJ40/MJ50, after five (5) years, customer pays 50% of the list price of frypot plus all labour, travel, mileage, freight and importation,

WHO IS COVERED

This Limited Warranty is available only to the original purchaser of the product and is not transferable.

EXCLUSIONS FROM COVERAGE

- Repair or replacement of parts required because of misuse, improper care or storage, negligence, alteration, accident, use of incompatible supplies or lack of specified maintenance shall be excluded;
- Normal maintenance items, including but not limited to, light bulbs, fuses, gaskets, O-rings, interior and exterior finishes, lubrication, de-liming, broken glass, etc.;
- Failures caused by improper or erratic voltages;
- Improper or unauthorized repair;
- Changes in adjustment and calibration after thirty (30) days from equipment installation date;
- This Limited Warranty will not apply to any parts subject to damage beyond the control of GC, or to equipment which has been subject to alteration, misuse or improper installation, accidents, damage in shipment, fire, floods, power changes, other hazards or acts of God that are beyond the control of GC;
- This Limited Warranty does not apply, and shall not cover any products or equipment manufactured or sold by GC when such products or commercial equipment is installed or used in a residential or non-commercial application. Installations not within the applicable building

or fire codes render this Limited Warranty and any responsibility or obligations associated therein null and void. This includes any damage, costs or legal actions resulting from the installation of any GC commercial cooking equipment in a non-commercial application or installation, where the equipment is being used for applications other than those approved for by GC;

- If any product is cleaned without using an approved GC cleaning solution, this Limited Warranty shall be void;
- Removal, alterations or obliteration of the rating plate;
- Consequential damages (the cost of repairing other property which is damaged). Loss of time, profits or any other incidental damages of any kind;
- Failure to program Computer Magic® appliances in accordance with programming procedures prescribed in your Frymaster Service and Owner's Manual.

LIMITATIONS OF LIABILITY

The preceding paragraphs set forth the exclusive remedy for all claims based on failure of, or defect in, products or services sold hereunder, whether the failure or defect arises before or during the warranty period, and whether a claim, however instituted, is based on contract, indemnity, warranty, tort (including negligence), strict liability, implied by statute, common-law or otherwise, and GC its servants and agents shall not be liable for any claims for personal injuries, incidents or consequential damages or loss, howsoever caused. Upon the expiration of the warranty period, all such liability shall terminate. **THE FOREGOING WARRANTIES ARE EXCLUSIVE AND IN LIEU OF ALL OTHER WARRANTIES, WHETHER WRITTEN, ORAL, IMPLIED OR STATUTORY. NO IMPLIED WARRANTY OF MERCHANTABILITY OR FITNESS FOR PARTICULAR PURPOSE SHALL APPLY, GC DOES NOT WARRANT ANY PRODUCTS OR SERVICES OF OTHERS.**

REMEDIES

The liability of GC for breach of any warranty obligation hereunder is limited to: (i) the repair or replacement of the equipment on which the liability is based, or with respect to services, re-performance of the services; or (ii) at GC's option, the refund of the amount paid for said equipment or services. Any breach by GC with respect to any item or unit of equipment or services shall be deemed a breach with respect to that item or unit or service only.

WARRANTY CLAIM PROCEDURE

Customer shall be responsible to:

- Immediately advise the Dealer or GC's Factory Authorized Servicer of the equipment serial number and the nature of the problem. For a list of Factory Authorized Services, please refer to www.garlandcanadaservice.ca;
- Verify that the problem is a factory responsibility. Improper installation or misuse of equipment, is not covered under this Limited Warranty;
- Cooperate with the Factory Authorized Servicer so that warranty service may be completed during normal working hours;
- Travel time not to exceed two (2) hours and mileage not to exceed one hundred fifty (150) kilometres. Does not include travel other than overland, overtime, holiday charges and any special arrangement.

GOVERNING LAW

For equipment, products and services sold in Canada this Limited Warranty shall be governed by the laws of the province of Ontario, Canada excluding their conflicts of law principles. The United Nations Convention on Contracts for the International Sale of Goods is hereby excluded in its entirety from application to this Limited Warranty.

Garland Canada

1177 Kamato Road
Mississauga, Ontario
Canada L4W1X4

www.garlandcanada.ca

LIMITED WARRANTY

Garland Canada (GC) warrants this product to be free from defects in material and workmanship for a period of one (1) year from the date the product is installed or twenty-four (24) months from the date of shipment from our facility, **whichever comes first**, and sold within Canada.

During the warranty period, GC shall, at GC's option, repair or replace parts determined by GC to be defective in material or workmanship, and with respect to services, shall re-perform any defective portion of said services. The foregoing shall be the sole obligation of GC under this Limited Warranty with respect to the equipment, products and services. With respect to equipment, materials, parts and Accessories manufactured by others, GC's sole obligation shall be to use reasonable efforts to obtain the full benefit of the manufacturer's warranties. GC shall have no liability, whether in contract, tort, negligence, or otherwise, with respect to non-GC manufactured products.

HOW LONG THE COVERAGE LASTS

Frypots are warranted to be free from defects which would cause shortening leaks due to weld failures for the period of one (1) year, parts and labour. Models listed below are warranted for parts only for the length of time indicated.

Models SM35G, SR38, SR42, SR52, SR62, TC25, TC35

- One (1) year mild steel • Five (5) years prorated stainless steel *

Models SM20, SM50, SM60, SM80

- One (1) year mild steel • Five (5) years stainless steel

Models 1824 and 2424

- Four (4) years

Models 1414E, 1818E, 2020E, 18UE

- Four (4) years stainless steel

Models 1414G, 1818G, 2020G

- Five (5) years stainless steel

Models D35G, D50G, D60G, D80G

- Five (5) years mild steel • Ten (10) years stainless steel

* PRO RATED FRYPOT WARRANTY

- First year customer pays labour only
- Second year customer pays labour, freight and 20% of current frypot list price
- Third year customer pays labour, freight and 40% of current frypot list price
- Fourth year customer pays labour, freight and 60% of current frypot list price
- Fifth year customer pays labour, freight and 80% of current frypot list price
- After fifth year customer pays labour, freight and 100% of frypot and freight.

WHO IS COVERED

This Limited Warranty is available only to the original purchaser of the product and is not transferable.

EXCLUSIONS FROM COVERAGE

- Repair or replacement of parts required because of misuse, improper care or storage, negligence, alteration, accident, use of incompatible supplies or lack of specified maintenance shall be excluded;
- Normal maintenance items, including but not limited to, light bulbs, fuses, gaskets, O-rings, interior and exterior finishes, lubrication, de-liming, broken glass, etc.;
- Failures caused by improper or erratic voltages;
- Improper or unauthorized repair;
- Changes in adjustment and calibration after thirty (30) days from equipment installation date;
- This Limited Warranty will not apply to any parts subject to damage beyond the control of GC, or to equipment which has been subject to alteration, misuse or improper installation, accidents, damage in shipment, fire, floods, power changes, other hazards or acts of God that are beyond the control of GC;
- This Limited Warranty does not apply, and shall not cover any products or equipment manufactured or sold by GC when such products or

commercial equipment is installed or used in a residential or non-commercial application. Installations not within the applicable building or fire codes render this Limited Warranty and any responsibility or obligations associated therein null and void. This includes any damage, costs or legal actions resulting from the installation of any GC commercial cooking equipment in a non-commercial application or installation, where the equipment is being used for applications other than those approved for by GC;

- If any product is cleaned without using an approved GC cleaning solution, this Limited Warranty shall be void;
- Removal, alterations or obliteration of the rating plate;
- Consequential damages (the cost of repairing other property which is damaged). Loss of time, profits or any other incidental damages of any kind.

LIMITATIONS OF LIABILITY

The preceding paragraphs set forth the exclusive remedy for all claims based on failure of, or defect in, products or services sold hereunder, whether the failure or defect arises before or during the warranty period, and whether a claim, however instituted, is based on contract, indemnity, warranty, tort (including negligence), strict liability, implied by statute, common-law or otherwise, and GC its servants and agents shall not be liable for any claims for personal injuries, incidents or consequential damages or loss, howsoever caused. Upon the expiration of the warranty period, all such liability shall terminate. **THE FOREGOING WARRANTIES ARE EXCLUSIVE AND IN LIEU OF ALL OTHER WARRANTIES, WHETHER WRITTEN, ORAL, IMPLIED OR STATUTORY. NO IMPLIED WARRANTY OF MERCHANTABILITY OR FITNESS FOR PARTICULAR PURPOSE SHALL APPLY, GC DOES NOT WARRANT ANY PRODUCTS OR SERVICES OF OTHERS.**

REMEDIES

The liability of GC for breach of any warranty obligation hereunder is limited to: (i) the repair or replacement of the equipment on which the liability is based, or with respect to services, re-performance of the services; or (ii) at GC's option, the refund of the amount paid for said equipment or services. Any breach by GC with respect to any item or unit of equipment or services shall be deemed a breach with respect to that item or unit or service only.

WARRANTY CLAIM PROCEDURE

Customer shall be responsible to:

- Immediately advise the Dealer or GC's Factory Authorized Servicer of the equipment serial number and the nature of the problem. For a list of Factory Authorized Services, please refer to www.garlandcanadaservice.ca;
- Verify that the problem is a factory responsibility. Improper installation or misuse of equipment, is not covered under this Limited Warranty;
- Cooperate with the Factory Authorized Servicer so that warranty service may be completed during normal working hours;
- Travel time not to exceed two (2) hours and mileage not to exceed one hundred fifty (150) kilometres. Does not include travel other than overland, overtime, holiday charges and any special arrangement.

GOVERNING LAW

For equipment, products and services sold in Canada this Limited Warranty shall be governed by the laws of the province of Ontario, Canada excluding their conflicts of law principles. The United Nations Convention on Contracts for the International Sale of Goods is hereby excluded in its entirety from application to this Limited Warranty.

Garland Canada

1177 Kamato Road
Mississauga, Ontario
Canada L4W1X4

www.garlandcanada.ca

Canadian Regional Sales Representatives



REGION	REP / AGENT	E-MAIL	CELLULAR
British Columbia	Ryan Lewis – Sales Rep	ryan@masales.ca	604-329-0684
	Mark Thiessen – Sales Rep	mark@masales.ca	604-657-7615
Alberta	James Goodman – Sales Rep (Calgary)	james@masales.ca	403-618-3636
	Collin Von Hansen – Sales Rep	collin@masales.ca	587-832-2090
	Sandro Salvador – Sales Rep (Edmonton)	sandro@masales.ca	780-405-2637
Prairies	Jeff McGowan – Sales Rep (SK, MB)	mcgowansales@bellnet.ca	647-231-3815
Ontario	Chris Ozog – Sales Rep (Central ON)	chris.ozog@garland-group.com	416-526-7989
	Geoff Scott – Sales Rep (Southern & Western ON)	geoff.scott@garland-group.com	647-828-9391
	Jeff McGowan – Sales Rep (Northeastern ON)	mcgowansales@bellnet.ca	647-231-3815
Quebec	Maxime Gaudreault – Sales Rep (Quebec City)	maxime.gaudreault@garland-group.com	437-577-3719
	Joey Mendolia – Sales Rep (Montreal)	joey.mendolia@garland-group.com	437-333-3447
Atlantic Canada	Aaron Taylor – Sales Rep (PEI, NB)	aaron@tayloragencies.com	506-872-1177
	Steven Donnelly – Sales Rep (NS, NL)	steven@tayloragencies.com	902-999-7631

GARLAND CANADA CUSTOMER SERVICE	VOICE	FAX
Sales	(888) 442-7526	(800) 361-2724
KitchenCare (Parts, Service and Warranty)	(844) 724-2273	N/A

Scan the code below to locate a dealer, distributor or sales representative in your area.



www.garlandcanada.ca/sales/buy-locally



Welbilt offers fully-integrated kitchen systems with award-winning product brands: **Cleveland**[™], **Convotherm**[®], **Delfield**[®], **Frymaster**[®], **Garland**[®], **Kolpak**[®], **Lincoln**[®], **Merco**[®], **Merrychef**[®] and **Multiplex**[®]. Supported by service brands: **KitchenCare**[®], aftermarket parts and service; **FitKitchen**[®], fully-integrated kitchen systems; and **KitchenConnect**[®], cloud-based open digital platform.

Bringing innovation to the table • welbilt.com