

Frymaster®

Canada Price List



Effective: January 5, 2026



Visit Welbilt Brand Portal:

<https://assets.welbilt.com/login/>



www.garlandcanada.ca



@thegarlandcanada

GARLAND®
CANADA
WELBILT DISTRIBUTION

Price List Canada

NOTICE:

FRYMASTER/ DEAN PRODUCTS ARE NOT APPROVED OR AUTHORIZED FOR HOME OR RESIDENTIAL USE, BUT ARE INTENDED FOR COMMERCIAL APPLICATIONS ONLY. FRYMASTER/ DEAN WILL NOT PROVIDE SERVICE, WARRANTY, MAINTENANCE OR SUPPORT OF ANY KIND OTHER THAN IN COMMERCIAL APPLICATIONS.

INSTRUCTIONS AND ASSISTANCE IN ORDERING

Specify the following information when ordering:

1. Your purchase order number
2. A specific deliver date/pick-up date
3. Specific shipping instructions, including the complete street address
4. Quantity and model number of unit(s) required
5. Pricing, including all discounts
6. Voltage, cycle (hz), and phase
7. Gas type, specific gravity and pressure (elevation requirements)
8. A drawing or layout sketch of all equipment line-ups of 2 or more units, including all gas hookups and cap position(s)
9. A copy of original quote, if applicable

SERVICE

When corresponding with the factory regarding service, performance or replacement parts, be sure to refer to the particular product by correct model number including prefix and suffix letters, numbers and serial number. This information can be found on the rating plate. Any information pertaining to performance parts or servicing can be obtained by writing our Mississauga office. Continuous product improvement is a Garland policy, therefore specifications and design are subject to change without notice.

TERMS AND CONDITIONS

All prices exclude the Goods and Services Tax (G.S.T.) and Provincial and Local Taxes. All prices are in Canadian Dollars.

Refer to Garland dealer policy for:

- A. Terms of Sale
- B. Equipment Returns or Order Cancellations
- C. Damaged Shipments

Garland Canada reserves the right to change warranties, accessories or product configurations without notice. Access our website at www.GarlandCanada.ca for current information which supercedes any printed information. Further inquiries may also be directed to Customer Service at 1-888-442-7526.

GARLAND CANADA CUSTOMER SERVICE	VOICE	FAX
Sales	(888) 442-7526	(800) 361-2724
KitchenCare (Parts, Service and Warranty)	(844) 724-2273	N/A

CONTENTS

Ordering Information	2
How to Select a Fryer	6-13
Dean Super Runner (SR) Value Gas Fryers	14
Super Runner Fryer Facts.....	14
SR42G	15
SR52G	16
SR62G	17
Standard GF Gas Fryers	18
GF14	18
GF40	19
Dean PowerRunner™ (PR) Gas Fryers	21
PowerRunner Fryer Facts	21
PRG50	22, 23
FPRG50	22, 23
Dean Decathlon (D) Gas Fryers	24
D60G	24
Performance MJ Gas Fryers	26
MJ Fryer Facts	26
MJ40	27
MJ50	28
MJCF	29
High Efficiency HD Gas Fryers	30
HD50G	35
HD60G	30
ESG35T Gas Fryer.....	33
ESG35T Gas Fryer Facts	33
ESG35T Gas Fryer.....	34
High-Efficiency H55 Gas Fryers.....	36
H55 Fryer	37

LHD65 Low Flue Temperature Gas Fryers38
LHD65.....38

OCF30 Oil-Conserving Gas Fryers41
OCF30 Oil-Conserving Gas Fryer Facts41
OCF30ATOG and Single OCF30G.....42

1814 Gas High-Production Fryers43
1814 Fryer Facts43
1814.....43

FilterQuick® Gas Fryers45
FilterQuick Fryer Facts45
FilterQuick 30 Series II Gas Fryers46
FilterQuick 60 Series II Gas Fryers47
FilterQuick 80 Series II Gas Fryers48
FilterQuick 100 Series II Gas Fryers.....49
FilterQuick 120 Series II Gas Fryers.....50

Dean Super Runner (SRE) Value Electric Fryer 53
SR14E 54

High Efficiency RE Electric Fryers..... 56
RE Fryer Facts 56
RETC 57-58
RE 59-62

OCF30 Oil-Conserving Electric Fryers.....64
OCF30 Fryer Facts..... 64
OCF30ATOE and Single OCF30..... 65

1814 High-Production Electric Fryers.....66
1814.....66

FilterQuick® Electric Fryers 68
FilterQuick Electric Fryer Facts.....68
FilterQuick 30 Series II Fryers69
FilterQuick 60 Series II Fryers 70
FilterQuick 80 Series II Fryers 71

CONTENTS *(continued)*

SPECIALTY PRODUCTS

Spreader Cabinet.....	73
Food Warmers.....	73
Holding Pans.....	73

OIL MANAGEMENT AND ACCESSORIES

Portable Filters	74-75
Shortening Disposal Unit	84
Cleaning Disposal Caddy.....	84
Filter Accessories	76

FRYER ACCESSORIES

Gas Fryer Accessories.....	76-79
Electric Fryer Accessories.....	80-81

PRODUCT SPECIFICATIONS

Gas Product Specifications	82
Electric Product Specifications	83
Specialty Product Specifications.....	84

SERVICE INFORMATION

Frymaster & Dean Factory Warranty.....	85
Frymaster & Dean Factory Warranty.....	87
Canadian Regional Sales Representatives.....	89

VALUE

When upfront cost is the driving factor. Value fryers are designed to economically meet your basic frying needs.

- Tube and open pot models available
- Millivolt only
- Casters standard; legs available as an option
- Single vat only
- Large, wide cold zone
- No built-in filtration options
- Can cook a variety of foods from french fries to main entrees
- No electric hook up required (except for the SR114)



DEAN
SR142



DEAN
SR152



DEAN
SR162



DEAN
GF40



DEAN
SR114

VALUE PERFORMANCE

When cost is a factor but performance matters. Designed for high-volume frying and controlled performance.

- Versatile
- Economical, tube fryers
- Higher production capacity than value models
- Decathlon (D60) capable of large batch cooking
- Melt cycle and boil out available
- Filtration available
- Multiple controller options available
- Multiple configurations available



DEAN
PRG50T-SPV



DEAN
PRG50T



DEAN
D60

HIGH PERFORMANCE

When increased production capacity is needed. Designed for versatile, controlled performance.

- Tube and open pot models available
- All-purpose cooking with higher production
- Economical
- Durable
- Improved warranties vs entry level models
- Built-in filtration available
- No electrical hookup required on some models
- Multiple configurations available



Frymaster
MJ40



Frymaster
MJ50



Frymaster
MJCF



Frymaster
HD60



Frymaster
GF14

HIGH EFFICIENCY

When ENERGY STAR® is a requirement. Designed for high-efficiency frying that meets ENERGY STAR guidelines.

- ENERGY STAR certified
- Low idle energy rate
- 50% or greater efficiency (gas)
- 80% or greater efficiency (electric)
- Open pot and tube options
- Built-in filtration options
- Multiple controller options
- Rebates available
- Gas and electric options
- One economically priced model

OIL CONSERVING

When oil savings are important. Designed for ultimate oil conservation and high performance.

- Less oil for same production capacity as larger vats
- Up to 40% savings in oil cost
- Energy saving mode
- Reduce operating costs by using less oil (vs larger capacity model)
- Built-in filtration
- Multiple controller options available
- ENERGY STAR Certified
- High efficiency

FILTERQUICK

When innovation matters. Harnessing the most innovative and intuitive features.

- Automatic filtration
- Oil Quality Sensor (OQS) optional
- Automatic Top Off (ATO) optional
- Low idle energy rate
- FQ4000 easyTouch touchscreen
- Internet capable
- Connectivity to the Cloud
- Visibility into fryer operations



**DEAN
ESG35T**



**Frymaster
HD50**



**Frymaster
H55**



**Frymaster
OCF30G**



**Frymaster
1814G**



**Frymaster
LHD65**



**Frymaster
OCF30E**



**Frymaster
1814E**



**Frymaster
FQG30**



**Frymaster
FQG60**



**Frymaster
FQG80**



**Frymaster
FQG100**



**Frymaster
FQG120**



**Frymaster
FQE30**



**Frymaster
RE14/TC**



**Frymaster
RE17/TC**



**Frymaster
RE80**



**Frymaster
FQE60**



**Frymaster
FQE80**

OIL CAPACITY		30-LBS.	40-LBS.	50-LBS.	60-LBS.
FRYPOT SIZE		14" x 14"			18" x 14"
GAS	TUBE	VALUE	SR142 PAGE 15	SR152 PAGE 16	
		VALUE PERFORMANCE		PRG50T-SPV PAGE 22 PRG50T PAGE 23	
		HIGH EFFICIENCY	ESG35T PAGE 34	HD50 PAGE 35	
		OIL CONSERVING			1814G PAGE 43
		FILTERQUICK			FQG60 PAGE 47
	OPEN	VALUE	GF14 PAGE 18	GF40 PAGE 19	
		HIGH PERFORMANCE	MJ40 PAGE 27	MJ50 PAGE 28	
		HIGH EFFICIENCY		H55 PAGE 37	
		OIL CONSERVING	OCF30G PAGE 42		
		FILTERQUICK	FQG30 PAGE 46		
ELECTRIC	OPEN	VALUE	SR114E PAGE 54		
		HIGH EFFICIENCY		RE14TC PAGE 57 RE17TC PAGE 58 RE14 PAGE 59 RE17 PAGE 60	
		OIL CONSERVING	OCF30E PAGE 65		1814E PAGE 66
		FILTERQUICK	FQE30 PAGE 69		FQE60 PAGE 70

OIL CAPACITY		75-LBS.	80-LBS.	100-LBS.	120-LBS.
FRYPOT SIZE		18" x 18"			20" x 20"
GAS	TUBE	VALUE	SR162 PAGE 17		
		VALUE PERFORMANCE		D60 PAGE 24	
		HIGH PERFORMANCE	HD60 PAGE 30		
		HIGH EFFICIENCY			LHD65 PAGE 38
		FILTERQUICK		FQG80 PAGE 48	FQG100 PAGE 49
ELECTRIC	OPEN	HIGH PERFORMANCE		MJCF PAGE 29	
		HIGH EFFICIENCY		RE80 PAGE 61	
		FILTERQUICK		FQE80 PAGE 71	

FRYER CATEGORY	MODELS	OIL CAPACITY	SPLIT POT OPTION	BUILT-IN FILTRATION	FREEZER-TO-FRYER	FRESH-BREADED	BONE-IN CHICKEN	FRESH-NAKED WINGS	KILOWATTS	PRODUCTION PER HOUR
VALUE	SR114 ¹	40-LBS.		N/A	●	●	●	●	14 kW	56-LBS. FRIES
HIGH EFFICIENCY	RE14 / RE17	50-LBS.	●	Option	●	●	●	●	14 / 17 kW	70-LBS. FRIES
	RE14TC / RE17TC	50-LBS.	●	Option	●	●	●	●	14 kW	74-LBS. FRIES
	RE80	80-LBS.		Option	●	●	●	●	17 / 21 kW	62-LBS. FRIES
OIL CONSERVING	OCF30	30-LBS.	●	Standard	●	● ²			14 kW	71-LBS. FRIES
	1814	63-LBS.		Option	●	●	●	●	17 kW	83-LBS. FRIES
FILTERQUICK	FQ30	30-LBS.		Automatic	●	●			14 kW	71-LBS. FRIES
	FQ60	60-LBS.		Automatic	●	●	●	●	17 kW	84-LBS. FRIES
	FQ80	80-LBS.		Automatic	●	●	●	●	17 kW	84-LBS. FRIES 80 PCS. BONE-IN CHICKEN

¹ Fixed elements | ² Frequent crumb and sediment removal required

FRYER CATEGORY	MODELS	OIL CAPACITY	FRYPOT DESIGN		SPLIT POT OPTION	BUILT-IN FILTRATION	FREEZER-TO-FRYER	FRESH-BREADED	BONE-IN CHICKEN	FRESH-NAKED WINGS	BTU PER HOUR	PRODUCTION PER HOUR
			OPEN	TUBE								
VALUE	SR142	43-LBS.		●		N/A	●	●		●	105K	57-LBS. FRIES
	SR152	50-LBS.		●		N/A	●	●		●	120K	60-LBS. FRIES
	SR162	75-LBS.		●		N/A	●	●	●	●	150K	86-LBS. FRIES
	GF14	40-LBS.	●			N/A	●			●	100K	57-LBS. FRIES
	GF40	50-LBS.	●			N/A	●			●	122K	69-LBS. FRIES
VALUE PERFORMANCE	D60	80-LBS.		●		Standard ¹	●	●	●	●	150K	92-LBS. FRIES
	PR	50-LBS.		●		Option	●	●		●	120K	63-LBS. FRIES
	PR-SPV	50-LBS.		●		N/A	●	●		●	120K	60-LBS. FRIES
HIGH PERFORMANCE	MJ40	40-LBS.	●			N/A	●			●	110K	57-LBS. FRIES
	MJ50	50-LBS.	●			N/A	●			●	122K	69-LBS. FRIES
	MJCF	80-LBS.	●			N/A	●	●	●	●	150K	80-PCS. BONE-IN CHICKEN
	HD60	75-LBS.		●		Option	●	●	●	●	125K	107-LBS. FRIES
HIGH EFFICIENCY	ESG35T	35-LBS.		●		N/A	●	●		●	70K	58-LBS. FRIES
	H55	50-LBS.	●		●	Option	●			●	80K	68-LBS. FRIES
	HD50	50-LBS.		●		Option	●	●	●	●	100K	72-LBS. FRIES
	LHD65	100-LBS.		●		Standard ¹	●	●	●	●	105K	128-PCS. BONE-IN CHICKEN
OIL CONSERVING	OCF30	30-LBS.	●		●	Standard	●	● ²			70K	67-LBS. FRIES
	1814	63-LBS.		●		Option	●	●	●	●	119K	84-LBS. FRIES
FILTERQUICK	FQ30	30-LBS.	●			Automatic	●	● ²		●	70K	67-LBS. FRIES
	FQ60	63-LBS.		●		Automatic	●	●	●	●	119K	87-LBS. FRIES
	FQ80	80-LBS.		●		Automatic	●	●	●	●	125K	107-LBS. FRIES 80-PCS. BONE-IN CHICKEN
	FQ100	100-LBS.		●		Automatic	●	●	●	●	105K	79-LBS. FRIES 105-PCS. BONE-IN CHICKEN
	FQ120	120-LBS.		●		Automatic	●	●	●	●	105K	128-PCS. BONE-IN CHICKEN

¹ Built-in filtration not available on single models | ² Frequent crumb and sediment removal required

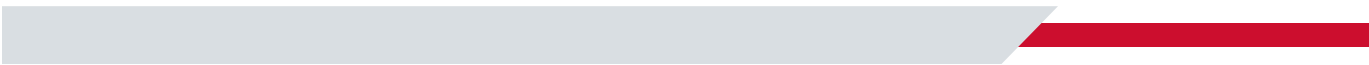

WHAT TYPE OF FRYER SHOULD I USE?

EQUIPMENT	DESCRIPTION	SEDIMENT ZONE	ADVANTAGES	DISADVANTAGES	GREAT FOR FRYING
-----------	-------------	---------------	------------	---------------	------------------

OPEN POT

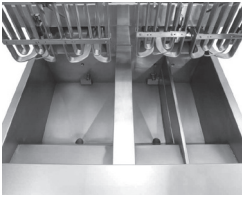

The term “open pot” refers to the unobstructed heated area of the frypot. Gas fryers heat the frypot from the outside of the pot. Electric fryers have a heating element in the interior of the frypot that is immersed in the oil. Frypots are made of stainless steel.

Open pot frypots are easy to clean but have a smaller sediment area than tube gas fryers. The open pot design allows the operator to visually monitor the amount of sediment in the bottom of the frypot.

Can be used for a broad range of low-to-medium sediment frying needs; easiest to clean. Frymaster’s electric fryers have elements that swing up and will stay up for easier cleaning.

Smaller sediment zone than most tube fryers; not suited for heavily breaded food products; and not ideal for specialty products.

Best applications are lightly breaded (lower sediment) and freezer-to-fryer breaded products (french fries, hot wings, cheese sticks, and poppers).

TUBE

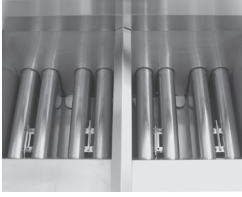

Tube fryers are gas fryers that have “tubes” in the bottom area of the frypot that are permanently attached to the frypot. The tubes transfer heat to the oil in the frypot. Frypots are made of stainless steel.

Large sediment zone which is ideal for high-sediment food product frying.

Can be used for a broad range of frying needs which include both low-sediment and higher-sediment products. Easily adaptable for frying a wide range of food products and large loads.

Harder to clean than an open frypot design.

Best applications are high-volume and higher-sediment food products.

GAS OR ELECTRIC?

GAS OPEN POT

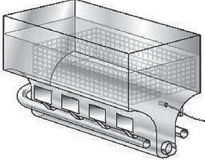

Efficiency of heat transfer depends on the type of burner

- Infrared — high efficiency
- Atmospheric — lower efficiency

GAS TUBE POT

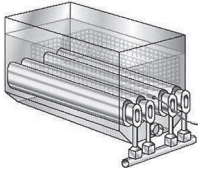

Efficiency of heat transfer depends on tube size and baffle system





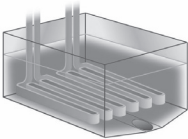



- 6" tubes/proprietary baffles — high efficiency
- 4" or 4" + tubes/standard baffles — lower efficiency

ELECTRIC POT

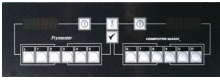

Electric units have more efficient heat transfer and faster recovery between frying cycles than gas open pot and tube units because the ribbon-type elements offer a larger surface area for heat to transfer directly into the oil.

Frymaster offers many different types of controllers. If you have a high-volume operation and want to ensure all employees will fry consistently to the same quality specifications, the more advanced controllers that offer compensation or “stretch” cooking would be best.

EQUIPMENT	DESCRIPTION	COOKING PERFORMANCE	MODEL OPTIONS
	<p>FQ4000 EASYTOUCH CONTROLLER*</p> <p>Touchscreen operation of cooking and fully-automatic filtration. Times the cook operation and signals visually and audibly when cook is complete. Controller operates the Automatic Top Off (ATO) feature. Controller helps manage oil through SmartFiltration, which prompts user when it is time to filter. On-screen, step-by-step prompts guide users through important functions, such as filtration, oil disposal, and boil out. Offers recipe configuration and management at the fryer or remotely with easy uploads of menu changes. Built-in connectivity supports operations management, including remote software updates.</p>	<p>Compensation or “stretch” cooking ensures the exact heat load will be utilized for each cook. The result is more consistent and higher quality food products.</p>	<p>FQ30, FQ60, FQ80, FQ100, FQ120</p>
	<p>3000 CONTROLLER*</p> <p>Operates standard built-in filtration. Offers push button cooking for 20 products. Times the cook operation and signals audibly when cooking is complete. Can display Fahrenheit or Celsius temperature values and stores the current time and temperature settings when the unit is turned off. Features temperature check, boil out, melt cycle and lighted digital display. Controller operates the Automatic Top Off (ATO) feature. Controller can monitor oil management functions such as cook counts, prompt when it is time to filter, and guide workers through step-by-step oil management functions such as filtration, oil dispose and boil out. Also can be programmed for segmented cooking that is used to cook bone-in chicken.</p>	<p>Compensation or “stretch” cooking ensures the exact heat load will be utilized for each cook. The result is more consistent and higher quality food products.</p>	<p>OCF30, LHD65, 1814, RE80, HD50, HD60</p>
	<p>3010 CONTROLLER*</p> <p>Operates standard built-in filtration. Offers push button cooking for 10 products. Times the cook operation and signals audibly when cooking is complete. Can display Fahrenheit or Celsius temperature values and stores the current time and temperature settings when the unit is turned off. Features temperature check, boil out, melt cycle and lighted digital display. Controller operates the Automatic Top Off (ATO) feature. Controller can monitor oil management functions such as cook counts, prompt when it is time to filter, and guide workers through step-by-step oil management functions such as filtration, oil dispose and boil out. Also can be programmed for segmented cooking that is used to cook bone-in chicken.</p>	<p>Compensation or “stretch” cooking ensures the exact heat load will be utilized for each cook. The result is more consistent and higher quality food products.</p>	<p>OCF30, LHD65, 1814, RE80, HD50, HD60</p>
	<p>LANE CONTROLLER</p> <p>Times the cook operation and signals audibly when cooking is complete. Automatically selects Fahrenheit/Celsius temperature values and stores the current time and temperature settings when the unit is turned off. The 3-Lane controller has 10 programmable product buttons, a 40-product library feature, temperature check, boil out, melt cycle, hold timers, cook compensation and lighted digital display. Control operates as a lane controller with the ability to select not only the product, but also where it will cook, lane 1, 2 or 3. A 2-lane version is available for the HD50 gas and RE electric fryers in the 1814 battery.</p>	<p>Compensation or “stretch” cooking ensures the exact heat load will be utilized for each cook. The result is more consistent and higher quality food products.</p>	<p>1814</p>
	<p>CM3.5 CONTROLLER*</p> <p>Smooth, touch-pad surface; multi-product programmable controller automatically stretches cook time to provide consistent food quality regardless of the product load. LEDs display cooking time countdown (with audible alarm) and provide precise frypot temperature checks. The unit also features controlled boil out at a steady 195°F (80°C), recovery “test time”, programmable “shake” and “hold” times and more. Available for full or split-pot fryers.</p>	<p>Compensation or “stretch” cooking ensures the exact heat load will be utilized for each cook. The result is more consistent and higher quality food products.</p>	<p>1814, H55, RE14, RE17, RE80, HD50G, HD60G, PR50</p>
	<p>DIGITAL TIMER CONTROLLER</p> <p>Touch-pad control panel is easy to operate for cooking and has timer function. Easy to operate with constant temperature display and timer function for cooks.</p>		<p>1814, H55, RE14, RE17, RE80, HD50G, HD60G, PR50</p>
	<p>THERMATRON CONTROLLER</p> <p>Standard controller for many DEAN fryers. Simple to operate with on/off switch, temperature set dial, and melt cycle and boil out options.</p>		<p>HD50G, HD60G, D60G, PR50, LHD65</p>
	<p>MILLIVOLT CONTROLLER</p> <p>Basic thermostat controller that gets energy from the gas flame. Requires no electrical hook-up.</p>		<p>ESG35T, MJ40, MJ50, MJCF, GF14, GF40, SR142, SR152, SR162, PR50</p>

*Basket lifts only available with CM3.5, 3000, 3010, and easyTouch controllers.

DEAN®



TUBE GAS FRYER

Super Runner Fryers (Gas and Electric) Outpace the Competition in Performance and Value



SR42 gas fryer shown with optional casters



SR14 electric fryer shown with optional casters



SR62 electric fryer shown with optional casters

- 1. Meet varied production capacity needs.** Model offerings provide 40-75 lb. oil capacity options.
- 2. Can be utilized in operations with gas or electric utilities.** There are four models, three gas and one electric.
- 3. Offer two gas frypot sizes: 14" x 14" and 18" x 18".**
- 4. Have a low warranty failure rate.**
- 5. Have sturdy, long-lasting construction** that includes stainless-steel frypot, door, and backsplash/flue cover.
- 6. Require no electrical hook-up for gas models.**
- 7. Offer an electric model that helps the kitchen stay cool.** Electric elements transfer heat directly to the oil so the kitchen stays cooler.
- 8. Protect against high-heat ignition with reliable high-limit probe.** Gas flow automatically shuts off if temperature exceeds the upper limit.
- 9. Support frying operations with durable accessories** including frypot covers, full size baskets, fine mesh screen, and casters. Triplet baskets are available for the SR62 model's 18" x 18" frypot.

Super Runner Fryers are the front running value fryer of choice.

For more information, contact Customer Service at 1-800-221-4583 or visit www.frymaster.com.

DEAN® SR142 SUPER RUNNER



TUBE GAS FRYER

- Tube-type frypot design
- Durable temperature probe
- Millivolt controller, no electrical connection required
- Thermo-tube design
- Wide cold zone
- Stainless steel frypot and door and aluminized sides
- Basket hanger
- 6" (15 cm) adjustable steel legs standard
- 3/4" (1.9 cm) NPT gas connection
- Basket support rack
- Twin baskets



SHOWN WITH OPTIONAL CASTERS

VALUE

SR FRYERS — With stainless steel frypot and door and aluminized sides.

MODEL	MILLIVOLT CONTROLLER	OIL CAPACITY	COOK AREA INCHES	INPUT BTU/HR	SHIPPING WEIGHT
SR142G	\$2,385	43-lbs.	14 W x 13-3/4 L x 4-1/5 D	105,000	150-lbs.

STANDARD ACCESSORIES

- Legs
- Rack-type Basket Support
- Basket Hanger
- Flue Deflector
- Twin Baskets

NOTES

- Split pots and basket lifts not available.
- If ordering for elevation above 2,000 feet, high elevation kit is required. Contact local service agent to order kits.
- Any questions or pricing information other than the above should be referred to Customer Service .

DEAN[®] SR152 SUPER RUNNER

TUBE GAS FRYER



SHOWN WITH OPTIONAL CASTERS

- Tube-type frypot design
- Durable temperature probe
- Millivolt controller — no electrical connection required
- Thermo-tube design
- Wide cold zone
- Stainless steel frypot and door and aluminized sides
- Basket hanger
- 6" (15 cm) adjustable steel legs standard
- 3/4" (1.9 cm) NPT gas connection
- Basket support rack
- Twin baskets

SR FRYERS — With stainless steel frypot and door and aluminized sides.

MODEL	MILLIVOLT CONTROLLER	OIL CAPACITY	COOK AREA INCHES	INPUT BTU/HR	SHIPPING WEIGHT
SR152G	\$3,790	50-lbs.	14 W x 14 L x 3-1/2 D	120,000	180-lbs.

STANDARD ACCESSORIES

- Legs
- Basket Hanger
- Rack-type Basket Support
- Twin Baskets

NOTES

- Split pots and basket lifts not available.
- If ordering for elevation above 2,000 feet, high elevation kit is required. Contact local service agent to order kits.
- Any questions or pricing information other than the above should be referred to Customer Service .

DEAN[®] SR162 SUPER RUNNER

TUBE GAS FRYER

- Tube-type frypot design
- Durable temperature probe
- Millivolt controller, no electrical connection required
- Thermo-tube design
- Wide cold zone
- Stainless steel frypot and door and aluminized sides
- Basket hanger
- 6" (15 cm) adjustable steel legs standard
- 3/4" (1.9 cm) NPT gas connection
- Basket support rack
- Twin baskets



SHOWN WITH OPTIONAL CASTERS

SR FRYERS — With stainless steel frypot and door and aluminized sides.

MODEL	MILLIVOLT CONTROLLER	OIL CAPACITY	COOK AREA INCHES	INPUT BTU/HR	SHIPPING WEIGHT
SR162G	\$5,320	75-lbs.	18 W x 18 L x 3-3/4 D	150,000	255-lbs.

STANDARD ACCESSORIES

- Legs
- Basket Hanger
- Flue Deflector
- Twin Baskets

NOTES

- Split pots and basket lifts not available.
- If ordering for elevation above 2,000 feet, high elevation kit is required. Contact local service agent to order kits.
- Any questions or pricing information other than the above should be referred to Customer Service .

Frymaster®

GF14



OPEN POT GAS FRYER



- Open pot design is easy to clean
- Millivolt controller, no electrical connection required
- Stainless steel frypot and door with aluminized sides
- Durable temperature probe
- Deep cold zone, 1-1/4" (3.2 cm) IPS ball-type drain valve
- Master Jet burner heat-transfer system
- Twin baskets
- Casters standard
- 3/4" (1.91 cm) (NPT) gas connection

GF FRYERS — With stainless steel frypot and door and aluminized sides.

MODEL	MILLIVOLT CONTROLLER	OIL CAPACITY	COOK AREA INCHES	INPUT BTU/HR	SHIPPING WEIGHT
GF14	\$2,955	40-lbs.	12 W x 15 L x 4 D	100,000	152-lbs.

STANDARD ACCESSORIES

- Casters
- Rack-type Basket Support
- Basket Hanger
- Flue Deflector
- Twin Baskets

GAS LINE INFORMATION

Fryers must be installed with proper size gas line. Each single unit requires a 3/4" NPT connection.

NOTES

- Split pots and basket lifts not available.
- If ordering for elevation above 2,000 feet, high elevation kit is required. Contact local service agent to order kits.
- DO NOT CURB MOUNT.
- Any questions or pricing information other than the above should be referred to Customer Service .

DEAN[®] GF40



OPEN POT GAS FRYER

- Open pot design is easy to clean
- Millivolt controller, no electric connection required
- Stainless steel frypot and door with aluminized sides
- Durable temperature probe
- Deep cold zone, 1-1/4" (3.2 cm) IPS ball-type drain valve
- Master Jet burner heat-transfer system
- Twin baskets
- Casters standard
- 3/4" (1.91 cm) (NPT) gas connection



VALUE

GF FRYERS — With stainless steel frypot and door and aluminized sides.

MODEL	MILLIVOLT CONTROLLER	OIL CAPACITY	COOK AREA INCHES	INPUT BTU/HR	SHIPPING WEIGHT
GF40	\$6,510	50-lbs.	14 W x 15 L x 5 D	122,000	176-lbs.

STANDARD ACCESSORIES

- Casters
- Rack-type Basket Support
- Basket Hanger
- Flue Deflector
- Twin Baskets

GAS LINE INFORMATION

Fryers must be installed with proper size gas line. Each single unit requires a 3/4" NPT connection.

NOTES

- Split pots and basket lifts not available.
- If ordering for elevation above 2,000 feet, high elevation kit is required. Contact local service agent to order kits.
- DO NOT CURB MOUNT.
- Any questions or pricing information other than the above should be referred to Customer Service .

PART #	DESCRIPTION	SIZE INCHES	APPLICABLE MODELS	PRICE
8030017	Basket, Full Size (Cannot be used with basket lifts)	17-1/2 W x 16-3/4 L x 6 D	SR162	\$640
8030099	Basket, Full Size (Can be used with TANDEM basket lifts)	12-3/8 W x 12-7/8 L x 5-1/4 D	SR142, SR152	\$615
8030015	Basket, Full Size (Cannot be used with basket lifts)	11-3/4 W x 14 L x 4-5/8 D	GF14	\$615
8030357	Basket, Triplet Size	4-1/2 W x 13-1/4 L x 6 D	GF40	\$420
8030427	Basket, Triplet Size	5-5/8 W x 15-7/8 L x 7-1/4 D	SR162	\$445
8030271	Basket, Twin Size	5-7/8 W x 12-5/8 L x 6-5/8 D	GF40, GF14, SR142, SR152	\$420
8030304	Basket, Twin Size	8-3/4 W x 16-3/4 L x 6 D	SR162	\$420
8102793	Basket Hanger	12-3/4 W x 3-1/2 L x 1-1/2 D	GF40, GF14, SR142, SR152	\$295
8102794	Basket Hanger	17-3/8 W x 3-1/2 H	SR162	\$295
8030132	Basket Support Rack Type — Full Pot	12-1/2 W x 13-3/4 D	GF40	\$295
8030032	Basket Support Rack Type — Full Pot	11-1/2 W x 14-5/8 D	GF14	\$295
8102235	Basket Support Rack Type	17-3/8 W x 17-5/8 D	SR162	\$425
8030273	Basket Support Rack Type	13-1/2 W x 13-1/4 D	SR152, SR142	\$295
8030277	Basket Support Rack, Fine Mesh	13-1/2 W x 13-1/4 D	SR152, SR142	\$355
8030149	Basket Support Rack, Fine Mesh	17 W x 17 D	SR162	\$420
8030136	Basket Support Screen Type With Handle — Full Pot	12-1/2 W x 13-3/4 D	GF40	\$355
8030037	Basket Support Screen Type Full Pot Only	11-1/2 W x 14-5/8 D	GF14	\$345
8030429	Brush L-Shaped, Tampico	21 L, 2 Diameter	All Models	\$205
8030278	Brush L-Shaped, Teflon	26-3/4 L, 1 Diameter	All Models	\$255
	Casters — Set of Four Call customer service to specify fryer models		All Models	\$685
8230619	Chicken/Fish Plate — Full Pot (Not available for split pot)	12-3/8 W x 14 D	GF40	\$770
8233048	Chicken/Fish Plate — Full Pot	11-3/4 W x 14-3/4 D	GF14	\$740
8030197	Clean-Out Rod	27 L	All Models	\$265
8239426	Cover — Stainless Steel — Full Pot	15-1/8 W x 20-1/4 D	GF40, GF14	\$595
1061637	Cover — Stainless Steel — Full Pot	13-1/2 W x 21-3/8 D	SR142, SR152	\$595
1061479	Cover — Stainless Steel without Basket Lifts	23-3/8 W x 19-3/4 D	SR162	\$700
8030059	Fish Scoop	8-1/8 W x 8-1/2 D with 17-3/8 handle	All Models	\$305
8030446	Fish Skimmer	6 square with 13-5/8 insulated handle, no hooks	All Models	\$295
9103557	Flue Deflector	12-1/2 W x 6-7/8 H	GF40, GF14	\$315
8030293	Gloves, Black Safety		All Models	\$185
8103169	Legs — Set of Four — Nickel Call customer service to specify fryer models	6 H		\$685
8101205	Legs — Set of Four — Stainless Steel Call customer service to specify fryer models	6 H		\$685
8061701	Quick Disconnect with 3/4" Gas Line Single Units	36 L	GF14, GF40	\$1,065
8061700	Quick Disconnect with 3/4" Gas Line Single Units	48 L	GF14, GF40	\$1,160
8030103	Sediment Tray — Full Pot	12-1/2 W x 14 L x 6-1/2 D	GF40	\$1,005
8030188	Sediment Tray — Full Pot	11-1/4 W x 14-1/2 L x 4-1/8 D	GF14, GF40	\$830
1062631	Sediment Tray	17-3/4 W x 17-1/8 D	SR162	\$1,220
8233225	Splash Shield	21-1/2 D x 13 H	SR142	\$355
2102681	Top Connecting Strip	2 W x 21-3/8 D	SR142, SR152	\$370
9102285	Top Connecting Strip	2-1/8 W x 20-5/8 L x 1-3/4 D	GF14, GF40	\$370



PowerRunner™ Gas Tube Fryers

Designed for durability and versatility

SEE WHY

Our PowerRunner Fryers are the NEW mid-size fryer of choice!

- 1. 50-lb. frypot capacity.** High-production cooking capacity and fast recovery meet high volume frying needs in this 14" frypot.
- 2. Multiple controller options.** There are four controller options: millivolt, thermatron, digital timer, and CM3.5.
- 3. Proven tube fryer design.** The Thermo-Tube heat transfer system ensures outstanding reliability and durability.
- 4. Built-in filter options.** Makes filtration quick, convenient, and reliable. Filtration extends oil life, reduces operating expense, and preserves food quality.
- 5. Multiple battery options.** This fryer is available as a single unit or a multi-battery unit (two to four frypots).
- 6. Accommodates a variety of frying needs.** Everything from French fries, breaded products and specialty foods.



1PRG50T gas fryer shown with optional casters

DEAN[®] PRG50T-SPV POWERRUNNER[®]

TUBE GAS FRYER



- Thermo-Tube design heat transfer system
- Millivolt controller, no electric connection required
- Durable temperature probe
- Shorter profile height
- Stainless steel frypot and door with aluminized sides
- Twin baskets
- Combination gas valve with regulator
- Wide cold zone
- 6" (15 cm) steel legs with 1" adjustment
- Wire basket hanger
- Basket support rack
- 3/4" NPT gas connection

POWERRUNNER-SPV FRYERS — Without filtration, stainless steel frypot and door with aluminized sides

MODEL	MILLIVOLT CONTROLLER	OIL CAPACITY	COOK AREA INCHES	INPUT BTU/HR	SHIPPING WEIGHT
1PRG50T-SPV	\$3,915	50-lbs.	14 W x 14 L x 3-1/2 D	120,000	188-lbs.

DESCRIPTION	PRICE
SPREADERS	

Spreader Cabinet—15MC **+\$1,980**

NOTE: Call Customer Service for availability and placement.

STANDARD ACCESSORIES

- Legs
- Basket Hanger
- Rack-type Basket Support
- Twin Baskets

GAS LINE TABLE

# OF FRYERS	GAS LINE
1	3/4"

NOTES

- Split pots and basket lifts not available.
- If ordering for elevation above 2,000 feet, high elevation kit is required. Contact local service agent to order kits.
- Any questions or pricing information other than the above should be referred to Customer Service.

DEAN[®] PRG50T POWER RUNNER[®]



TUBE GAS FRYER

- Thermo-Tube design heat transfer system
- Built-in filtration optional
- Millivolt controller, standard (no electric connection required)
- Durable temperature probe
- Stainless-steel frypot, door, and sides
- Twin baskets
- 1-1/4" NPT gas connection with 1" bushing
- Combination gas valve with regulator
- Wide cold zone
- Drain safety switch



SHOWN WITH OPTIONAL CASTERS

VALUE PERFORMANCE

POWERRUNNER FRYERS — Without filtration, stainless steel frypots(s), door(s), and sides.

MODEL	MILLIVOLT CONTROLLER*	THERMATRON CONTROLLER	DIGITAL TIMER CONTROLLER	CM3.5 CONTROLLER	OIL CAPACITY	COOK AREA INCHES	INPUT BTU/HR	SHIPPING WEIGHT
1PRG50T	\$8,590	\$9,360	\$10,225	\$13,660	(1) 50-lbs.	(1) 14 W x 14 L x 3-1/2 D	(1) 120,000	188-lbs.
2PRG50T	\$17,170	\$18,705	\$20,455	\$27,315	(2) 50-lbs.	(2) 14 W x 14 L x 3-1/2 D	(2) 120,000	404-lbs.
3PRG50T	\$25,765	\$28,065	\$30,675	\$40,970	(3) 50-lbs.	(3) 14 W x 14 L x 3-1/2	(3) 120,000	572-lbs.
4PRG50T	\$34,350	\$37,410	\$40,900	\$54,635	(4) 50-lbs.	(4) 14 W x 14 L x 3-1/2	(4) 120,000	772-lbs.

*Standard with Millivolt controller.

POWERRUNNER FRYERS — With filtration, stainless steel frypots(s), door(s), and sides.

MODEL	MILLIVOLT CONTROLLER*	THERMATRON CONTROLLER	DIGITAL TIMER CONTROLLER	CM3.5 CONTROLLER	OIL CAPACITY	COOK AREA INCHES	INPUT BTU/HR	SHIPPING WEIGHT
1FPRG50T	\$20,050	\$20,815	\$21,675	\$25,090	(1) 50-lbs.	(1) 14 W x 14 L x 3-1/2 D	(1) 120,000	397-lbs.
2FPRG50T	\$30,845	\$32,360	\$34,020	\$40,190	(2) 50-lbs.	(2) 14 W x 14 L x 3-1/2 D	(2) 120,000	397-lbs.
3FPRG50T	\$41,540	\$43,780	\$46,185	\$58,485	(3) 50-lbs.	(3) 14 W x 14 L x 3-1/2 D	(3) 120,000	610-lbs.
4FPRG50T	\$51,540	\$54,495	\$57,850	\$71,255	(4) 50-lbs.	(4) 14 W x 14 L x 3-1/2 D	(4) 120,000	910-lbs.

*Standard with Millivolt controller. NOTES: Filter price included. | Casters included in pricing.

DESCRIPTION	PRICE
-------------	-------

SPREADERS

Spreader Cabinet—15MC **+\$1,980**

NOTE: Call Customer Service for availability and placement.

BASKET LIFTS

Basket Lifts **+\$4,595 / FRYPOT**

Tandem basket lifts **+\$190 / FRYPOT**

NOTE: Basket lifts only available with CM3.5

STANDARD ACCESSORIES

- Legs (non filter models)
- Casters (filter models)
- Basket Hanger
- Rack-type Basket Support
- Twin Baskets

GAS LINE TABLE

# OF FRYERS	GAS LINE
1	3/4"
2-4	1"

GAS MANIFOLD REQUIREMENTS

1" Rear Gas Manifold (only available for batteries with 2 or more frypots)	With Shut-Off Valve	+\$195
	Without Shut-Off Valve	Standard

NOTES

- Split pot not available.
- If elevation is between 2,000-6,000 feet, specify the elevation level. Fryer may not perform at optimum levels above this elevation.
- Casters included in basket lift pricing.
- Any questions or pricing information other than the above should be referred to Customer Service.

DEAN® D60 DECATHLON



TUBE GAS FRYER

- Thermo-tube design heat transfer system
- Thermo-tube controller, standard
- Robust, RTD, 1° compensating temperature probe
- Stainless steel frypot, door, and sides
- Twin baskets
- 3/4" NPT gas connection
- Combination gas valve with regulator
- Wide cold zone
- Melt cycle and boil out mode
- 6" (15 cm) steel legs with 1" adjustment



SHOWN WITH OPTIONAL CASTERS

DECATHLON FRYER — Without filtration, stainless steel frypot, door, and sides.

MODEL	THERMATRON CONTROLLER	OIL CAPACITY	COOK AREA INCHES	INPUT BTU/HR	SHIPPING WEIGHT
D160G	\$11,280	75-lbs.	18 W × 18 L × 3-3/4 D	150,000	255-lbs.

DECATHLON D60 FRYERS — With filtration, stainless steel frypots, doors, and sides.

MODEL	THERMATRON CONTROLLER	OIL CAPACITY	COOK AREA INCHES	INPUT BTU/HR	SHIPPING WEIGHT
SCFD260G	\$33,950	(2) 75	(2) 18 W × 18 L × 3-3/4 D	(2) 150,000	417-lbs.
SCFD360G	\$46,955	(3) 75	(3) 18 W × 18 L × 3-3/4 D	(3) 150,000	815-lbs.
SCFD460G	\$59,935	(4) 75	(4) 18 W × 18 L × 3-3/4 D	(4) 150,000	1,295-lbs.

NOTES: Filter price included. | Casters included in pricing.

DESCRIPTION	PRICE
SPECIAL OIL OPTIONS	
External oil discharge — available on built-in filter batteries of 2 or more frypots or a frypot and spreader. Must specify front or rear connection. Front connection comes with 5 ft. washdown hose.	FRONT +\$2,730 REAR +\$2,090
SPREADERS	
Spreader Cabinet—20MC	+\$2,695

NOTE: Call Customer Service for availability and placement.

STANDARD ACCESSORIES

- Automatic Melt Cycle
- Boil Out Temperature Control
- Legs (non-filter fryers)
- Casters (filter models)
- Rack-type Basket Support
- Basket Hanger
- Twin Baskets

GAS LINE TABLE

# OF FRYERS	GAS LINE	
	SINGLES	
1	3/4"	N/A
2-4	N/A	(1) 1"

GAS MANIFOLD REQUIREMENTS

1" Rear Gas Manifold (only available for batteries with 2 or more frypots)	With Shut-Off Valve	+\$195
	Without Shut-Off Valve	Standard

NOTES

- Split pots and basket lifts not available.
- If ordering for elevation above 2,000 feet, high elevation kit is required. Contact local service agent to order kits.
- Any questions or pricing information other than the above should be referred to Customer Service.

PART #	DESCRIPTION	SIZE INCHES	APPLICABLE MODELS	PRICE
8030017	Basket, Full Size (Cannot be used with basket lifts)	17-1/2 W x 16-3/4 L x 6 D	D60	\$640
8030099	Basket, Full Size (Can be used with TANDEM basket lifts)	12-3/8 W x 12-7/8 L x 5-1/4 D	PRG50	\$615
8030148	Basket, Full Size (Can be used with TANDEM basket lifts)	17-1/2 W x 16-3/4 L x 5-7/8 D	D60G	\$640
8030357	Basket, Triplet Size	4-1/2 W x 13-1/4 L x 6 D	PRG50	\$420
8030427	Basket, Triplet Size	5-5/8 W x 15-7/8 L x 7-1/4 D	D60	\$445
8030271	Basket, Twin Size	5-7/8 W x 12-5/8 L x 6-5/8 D	PRG50	\$420
8030304	Basket, Twin Size	8-3/4 W x 16-3/4 L x 6 D	D60	\$420
2102737	Basket Hanger — Over The Flue	20 W x 6-5/8 H	D60G (singles) Call customer service for batteries	\$295
8102235	Basket Support Rack Type	17-3/8 W x 17-5/8 D	D60	\$425
8030273	Basket Support Rack Type	13-1/2 W x 13-1/4 D	PRG50	\$295
8030277	Basket Support Rack, Fine Mesh	13-1/2 W x 13-1/4 D	PRG50	\$355
8030149	Basket Support Rack, Fine Mesh	17 W x 17 D	D60	\$420
8030429	Brush L-Shaped, Tampico	21 L, 2 Diameter	All Models	\$205
8030278	Brush L-Shaped, Teflon	26-3/4 L, 1 Diameter	All Models	\$255
	Casters — Set of Four Call customer service to specify fryer models		All Models	\$685
8236895	Fish / Chicken Plate — Full Pot, Stainless steel	13-1/2 W x 16-1/2 D x 11 H	PRG50	\$420
8233947	Chicken/Fish Tray — Full Pot	16-1/2 W x 16-1/2 L x 11 D	D60	\$850
8030197	Clean-Out Rod	27 L	All Models	\$265
1061637	Cover — Stainless Steel — Full Pot	13-1/2 W x 21-3/8 D	PRG50	\$595
1061479	Cover — Stainless Steel without Basket Lifts	23-3/8 W x 19-3/4 D	D60	\$700
1062734	Cover — Stainless Steel w/Basket Lifts	14-1/4 W x 20-1/2 D	PRG50	\$555
1062773	Cover — Stainless Steel w/Basket Lifts	18 W x 22-5/8 D	D60	\$700
8030059	Fish Scoop	8-1/8 W x 8-1/2 D with 17-3/8 L handle	All Models	\$305
8030446	Fish Skimmer	6 square with 13-5/8 L insulated handle, no hooks	All Models	\$295
8030293	Gloves, Black Safety		All Models	\$185
2003649	Flue deflector	18-3/8 W x 3 H	D60	\$345
2003651	Flue deflector	15-3/8 W x 3 H	PRG50	\$255
8103169	Legs — Set of Four — Nickel Call customer service to specify fryer models	6 H		\$685
8101205	Legs — Set of Four — Stainless Steel Call customer service to specify fryer models	6 H		\$685
1064136	Sediment Tray	13-1/2 W x 13-3/4 D	PRG50	\$1,035
1062631	Sediment Tray	17-3/4 W x 17-1/8 D	D60	\$1,220
8233225	Splash Shield	21-1/2 D x 13 H	PRG50	\$355
8235744	Splash Shield	23-1/2 D x 14 H	D60	\$355
2102681	Top Connecting Strip	2 W x 21-3/8 D	PRG50	\$370
2105086	Top Connecting Strip	2 W x 23-5/8 D	D60	\$370



MJ Fryers (MJ40, MJ50 and MJCF)

World-Recognized Master of Open-Pot Frying



MJ40 fryer shown with optional digital controller and casters



MJ50 battery shown with millivolt controller and casters



MJCF fryer with optional electronic timer controller and casters

- 1. Offer an open-pot gas line-up unmatched in the industry.** Model offerings provide 40, 50, and 80-lb. oil capacity options with and without electrical hook-up. Respective fry areas are 12" x 15", 14" x 15", and 18" x 19". Respective Btu/hr inputs are 104,000, 122,000, and 150,000.
- 2. Have models that can handle the breadth of menu items** from French fries to breaded fish to bone-in chicken.
- 3. Are named for their signature Master Jet burner** technology that has earned a legendary reputation for durability and reliability. MJ burners require no burner cleaning or air shutter adjustment.
- 4. Are easy to clean.** Open-pot design allows safe access to every inch of the frypot.
- 5. Are simple to operate.** Just set the desired frying temperature and start cooking.
- 6. Automatically shut off the fryer** if temperature exceeds the high-limit.
- 7. Collect and aid sediment removal** with a deep collection zone and large 1-1/4" IPS ball-type drain valve

MJ Fryers are unsurpassed in their versatility, proven worldwide performance, and low maintenance needs.

Frymaster[®] MJ40



OPEN POT GAS FRYER

- Open pot design is easy to clean
- Master Jet burner system distributes heat evenly for efficient heat exchange and quick recovery
- Millivolt controller, no electric connection required
- Stainless steel frypot, door, and sides
- Reliable, centerline, fast-action temperature probe
- Deep cold zone, 1-1/4 in. (3.2 cm) IPS ball-type drain valve
- Twin baskets
- Over-the-flue basket hangers
- Casters standard on MJ140
- Batteries have casters installed
- EZSpark™ push-button ignitor
- Frypot cover(s)



HIGH PERFORMANCE

MJ40 FRYERS — Without filtration, with stainless steel frypot(s), door(s), and sides.

MODEL	MILLIVOLT CONTROLLER	OIL CAPACITY	COOK AREA INCHES	INPUT BTU/HR	SHIPPING WEIGHT
MJ140	\$5,000	(1) 40	(1) 12 W × 15 L × 4-1/4 D	(1) 110,000	185-lbs.
MJ240	\$9,835	(2) 40	(2) 12 W × 15 L × 4-1/4 D	(2) 110,000	370-lbs.
MJ340	\$14,215	(3) 40	(3) 12 W × 15 L × 4-1/4 D	(3) 110,000	555-lbs.

DESCRIPTION	PRICE
SPREADERS	
Spreader Cabinet—15MC	+\$2,405
Center Spreader	+\$2,615

NOTE: Call Customer Service for availability and placement.

STANDARD ACCESSORIES

- Rack-type Basket Support
- Basket Hanger
- Frypot Covers
- EZSpark Ignitor
- Flue Deflector
- Casters
- Twin Baskets

GAS LINE TABLE

# OF FRYERS	GAS LINE
1	3/4"
2-3	1"

NOTES

- Split pots and basket lifts not available.
- Call Customer Service — Toll Free 1-800-221-4583 or refer to manual provided with fryer for correct sizing information including high elevation installations.
- If elevation is between 2,000-6,000 feet, specify the elevation level. Not available above 6,000 feet.
- DO NOT CURB MOUNT.
- Any questions or pricing information other than the above should be referred to Customer Service.

Frymaster[®] MJ50



OPEN POT GAS FRYER

- Open pot design is easy to clean
- Master Jet burner system distributes heat evenly for efficient heat exchange and quick recovery
- Millivolt controller, no electric connection required
- Stainless steel frypot, door, and sides
- Reliable, centerline, fast-action temperature probe
- Deep cold zone, 1-1/4 in. (3.2 cm) IPS ball-type drain valve
- Twin baskets
- Over-the-flue basket hanger
- Legs and casters standard on MJ150
- Batteries have casters installed
- EZSpark™ push-button ignitor
- Frypot cover(s)



MJ50 FRYERS — Without filtration, with stainless steel frypot(s), door(s), and sides.

MODEL	MILLIVOLT CONTROLLER	OIL CAPACITY	COOK AREA INCHES	INPUT BTU/HR	SHIPPING WEIGHT
MJ150	\$7,655	(1) 50	(1) 14 W x 15 L x 5 D	(1) 122,000	202-lbs.
MJ250	\$15,095	(2) 50	(2) 14 W x 15 L x 5 D	(2) 122,000	404-lbs.
MJ350	\$22,570	(3) 50	(3) 14 W x 15 L x 5 D	(3) 122,000	606-lbs.

DESCRIPTION	PRICE
SPREADERS	
Spreader Cabinet—15MC	+\$2,405
Center Spreader	+\$2,615

NOTE: Call Customer Service for availability and placement.

STANDARD ACCESSORIES	
• Rack-type Basket Support	• Flue Deflector
• Basket Hanger	• Casters
• Frypot Cover(s)	• Twin Baskets
• EZSpark Ignitor	

GAS LINE TABLE	
# OF FRYERS	GAS LINE
1	3/4"
2-3	1"

NOTES

- Split pots and basket lifts not available.
- Call Customer Service — Toll Free 1-800-221-4583 or refer to manual provided with fryer for correct sizing information including high elevation installations.
- If elevation is between 2,000-6,000 feet, specify the elevation level.
- Not available above 6,000 feet.
- DO NOT CURB MOUNT.
- Any questions or pricing information other than the above should be referred to Customer Service.

Frymaster[®] MJCF



OPEN POT GAS FRYER

- Open pot design is easy to clean
- Millivolt controller, no electric connection required
- Stainless steel frypot, door, and sides
- Reliable, centerline, fast-action temperature probe
- Deep cold zone, 1-1/4 in. (3.2 cm) IPS ball-type drain valve
- Master Jet burners ensure even heat distribution
- Twin baskets
- 6" steel legs with 1" adjustment standard
- 3/4" gas connection



SHOWN WITH OPTIONAL CASTERS

HIGH PERFORMANCE

MJCF FRYER — Without filtration, stainless steel frypot, door, and sides.

MODEL	MILLIVOLT CONTROLLER	OIL CAPACITY	COOK AREA INCHES	INPUT BTU/HR	SHIPPING WEIGHT
MJ1CF	\$8,835	80-lbs.	18 W x 19 L x 4-1/2 D	150,000	297-lbs.

DESCRIPTION	PRICE
SPREADERS	
Spreader Cabinet—20MC	+\$3,185

STANDARD ACCESSORIES
<ul style="list-style-type: none"> • Legs • Rack-type Basket Support • Basket Hanger • Twin Baskets

GAS LINE TABLE	
# OF FRYERS	GAS LINE
1	3/4"

NOTES

- Split pots and basket lifts not available.
- Call Customer Service — Toll Free 1-800-221-4583 or refer to manual provided with fryer for correct sizing information including high elevation installations.
- If elevation is between 2,000-6,000 feet, specify the elevation level.
- Not available above 6,000 feet.
- DO NOT CURB MOUNT.
- Any questions or pricing information other than the above should be referred to Customer Service.

Frymaster[®] HD60



TUBE GAS FRYER

- High-efficiency Thermo-Tube frypot design
- Thermatron controller, standard
- Electronic ignition
- Robust, RTD, 1° compensating temperature probe
- Large capacity, high performance gas fryers suitable for volume frying
- Stainless steel frypot, door, and sides
- Twin baskets
- Wide cold zone, 1-1/4" to 1-1/2" full-port IPS ball-type drain valve
- 3/4" gas connection
- Melt cycle and boil out mode
- 6" (15 cm) steel legs with 1" adjustment



SHOWN WITH OPTIONAL CASTERS

HD FRYERS — Without filtration, stainless steel frypots, door, and sides.

MODEL	THERMATRON CONTROLLER*	CM3.5 CONTROLLER	3000 CONTROLLER	OIL CAPACITY	COOK AREA INCHES	INPUT BTU/HR	SHIPPING WEIGHT
HD160G	\$12,405	\$17,620	\$18,360	75-lbs.	18 W x 18 L x 3-3/4 D	125,000	255-lbs.

*Standard with Thermatron controller.

HD60 FRYER BATTERIES — With filtration, stainless steel frypot(s), door(s) and sides.

MODEL	THERMATRON CONTROLLER*	CM3.5 CONTROLLER	3000 CONTROLLER	OIL CAPACITY	COOK AREA INCHES	INPUT BTU/HR	SHIPPING WEIGHT
CFHD160G	\$21,930	\$27,130	\$27,885	(1) 75-lbs.	(1) 18 W x 18 L x 3-3/4 D	(1) 125,000	354-lbs.
SCFHD260G	\$39,640	\$50,070	\$51,530	(2) 75-lbs.	(2) 18 W x 18 L x 3-3/4 D	(2) 125,000	677-lbs.
SCFHD360G	\$53,720	\$69,380	\$71,580	(3) 75-lbs.	(3) 18 W x 18 L x 3-3/4 D	(3) 125,000	1,083-lbs.
SCFHD460G	\$67,810	\$88,680	\$91,615	(4) 75-lbs.	(4) 18 W x 18 L x 3-3/4 D	(4) 125,000	1,403-lbs.

*Standard with Thermatron controller.

NOTES: Filter price included. | Filter price includes casters. | 8 GPM pump standard.

DESCRIPTION	PRICE
SPECIAL OIL OPTIONS	
External oil discharge — available on built-in filter batteries of 2 or more frypots or a frypot and spreader. Must specify front or rear connection. Front connection comes with 5 ft. washdown hose.	FRONT +\$2,730 REAR +\$2,090
SPREADERS	
HD60G — 20MC	+\$2,830
NOTE: Call Customer Service for availability and placement.	
BASKET LIFTS	
Basket Lifts	+\$4,595 / FRYPOT
NOTE: not available with Thermatron controller	

STANDARD ACCESSORIES	
• Electronic Ignition	• Rack-type Basket Support
• Automatic Melt Cycle	• Basket Hanger
• Boil Out Temperature Control	• Twin Baskets
• Legs (non-filter models)	• Drain Safety Switch
	• Casters (filter models)

GAS LINE TABLE	
# OF FRYERS	GAS LINE
1	3/4"
2-4	1"

NOTES

- Split pots not available.
- If elevation is between 2,000-6,000 feet, specify the elevation level. Fryer may not perform at optimum levels above this elevation.
- Casters included in basket lift pricing.
- Any questions or pricing information other than the above should be referred to Customer Service

PART #	DESCRIPTION	SIZE INCHES	APPLICABLE MODELS	PRICE
8100088	Quick Disconnect with 1" Gas Line Systems Only	36 L	HD60, MJCF	\$1,320
8100085	Quick Disconnect with 1" Gas Line Systems Only	48 L	MJ50	\$1,410
8030015	Basket, Full Size (Cannot be used with basket lifts)	11-3/4 W x 14 L x 4-5/8 D	MJ40	\$615
8030148	Basket, Full Size (Can be used with TANDEM basket lifts)	17-1/2 W x 16-3/4 L x 5-7/8 D	HD60	\$640
8030357	Basket, Triplet Size	4-1/2 W x 13-1/4 L x 6 D	MJ50	\$420
8030023	Basket, Triplet Size	5-3/4 W x 17-1/8 L x 6-1/8 D	MJCF	\$480
8030427	Basket, Triplet Size	5-5/8 W x 15-7/8 L x 7-1/4 D	HD60	\$445
8030271	Basket, Twin Size	5-7/8 W x 12-5/8 L x 6-5/8 D	MJ40, MJ50	\$420
8030024	Basket, Twin Size	8-3/4 W x 16-3/4 L x 6 D	MJCF	\$570
8030304	Basket, Twin Size	8-3/4 W x 16-3/4 L x 6 D	HD60	\$420
8102793	Basket Hanger	12-3/4 W x 3-1/2 L x 1-1/2 D	MJ40, MJ50	\$295
130001403	Basket Hanger	39-3/4 W x 11-1/2 H	FQG80 (2 frypots)	\$560
2601808	Basket Hanger, Flue Mounted		MJ40, MJ50	\$255
8102794	Basket Hanger	17-3/8 W x 3-1/2 H	MJCF	\$295
130001407	Basket Hanger	59-3/4 W x 11-1/2 H	FQG80 (3 frypots)	\$760
2102737	Basket Hanger — Over The Flue	20 W x 6-5/8 H	HD60 (singles) Call customer service for batteries	\$295
8030132	Basket Support Rack Type — Full Pot	12-1/2 W x 13-3/4 D	MJ50	\$295
8030032	Basket Support Rack Type — Full Pot	11-1/2 W x 14-5/8 D	MJ40	\$295
8030137	Basket Support Rack Type — Full Pot	17-1/2 W x 17-1/2 D	MJCF	\$345
8102235	Basket Support Rack Type	17-3/8 W x 17-5/8 D	HD60	\$425
8030149	Basket Support Rack, Fine Mesh	17 W x 17 D	HD60	\$420
8030136	Basket Support Screen Type With Handle – Full Pot Only	12-1/2 W x 13-3/4 D	MJ50	\$355
8030037	Basket Support Screen Type Full Pot Only	11-1/2 W x 14-5/8 D	MJ40	\$345
8030138	Basket Support Screen Type With Handle — Full Pot Only	17-1/2 W x 18-1/2 D	MJCF	\$295
8030429	Brush L-Shaped, Tampico	21 L, 2 Diameter	All Models	\$205
8030278	Brush L-Shaped, Teflon	26-3/4 L, 1 Diameter	All Models	\$255
	Casters – Set of Four Call Customer Service to Specify Fryer Models		All Models	\$685
8230619	Chicken/Fish Plate — Full Pot (Not available for split pot)	12-3/8 W x 14 D	MJ50	\$770
8233048	Chicken/Fish Plate — Full Pot	11-3/4 W x 14-3/4 D	MJ40	\$740
8230368	Chicken/Fish Plate — Full Pot	17-7/8 W x 18 5/8 D	MJCF	\$770
8233947	Chicken/Fish Tray — Full Pot	16-1/2 W x 16-1/2 L x 11 D	HD60	\$850
8030197	Clean-Out Rod	27 L	All Models	\$265
8239413	Cover — Stainless Steel	20-3/8 W x 28 D	MJCF	\$595
8239426	Cover — Stainless Steel — Full Pot	15-1/8 W x 20-1/4 D	MJ40, MJ50	\$595
1061479	Cover — Stainless Steel without Basket Lifts	23-3/8 W x 19-3/4 D	HD60	\$700
8233938	Crumb Scoop Cold Zone	1-1/4 W x 6-1/2 D x 22-3/4 L	All Models	\$295
8030059	Fish Scoop	8-1/8 W x 8-1/2 D with 17-3/8 L handle	All Models	\$305
8030446	Fish Skimmer	6 square with 13-5/8 L insulated handle, no hooks	All Models	\$295
9103557	Flue Deflector	12-1/2 W x 6-7/8 H	MJ40, MJ50	\$315
9103185	Flue Deflector	14-1/2 W x 8 H	MJCF	\$315
	Foam Deck Basket Banger		MJ50, HD60	\$480 / FRYPOT
8030293	Gloves, Black Safety		All Models	\$185
8103169	Legs – Set of Four – Nickel Call customer service to specify fryer models	6 H		\$685
8101205	Legs – Set of Four – Stainless Steel Call customer service to specify fryer models	6 H		\$685

PART #	DESCRIPTION	SIZE INCHES	APPLICABLE MODELS	PRICE
8100088	Quick Disconnect with 1" Gas Line Systems Only	36 L	All Models	\$1,320
8100085	Quick Disconnect with 1" Gas Line Systems Only	48 L	All Models	\$1,410
8061701	Quick Disconnect with 3/4" Gas Line Single Units	36 L	MJ40, MJ50	\$1,065
8061700	Quick Disconnect With 3/4" Gas Line Single Units	48 L	MJ40, MJ50	\$1,160
8030103	Sediment Tray — Full Pot	12-1/2 W x 14 L x 6-1/2 D	MJ50	\$1,005
8030188	Sediment Tray — Full Pot	11-1/4 W x 14-1/2 L x 4-1/8 D	MJ40	\$830
8030187	Sediment Tray — Full Pot	17-1/2 W x 18-1/2 L x 4-3/8 D	MJCF	\$1,000
1062631	Sediment Tray	17-3/4 W x 17-1/8 D	HD60	\$1,220
8236559	Splash Shield	20 D x 6-1/4 H	MJ40, MJ50	\$595
8235978	Splash Shield	30-3/8 D x 13-1/8 H	MJCF	\$595
8235744	Splash Shield	23 1/2 D x 14 H	HD60	\$355
2109291	Top Connecting Strip	2-1/4 W x 20-1/2 D	MJ40, MJ50	\$370
9102662	Top Connecting Strip	2-1/8 W x 28-1/8 D	MJCF	\$425
2105086	Top Connecting Strip	2 W x 23-5/8 D	HD60	\$370



ESG35T ENERGY STAR® Value, High-Efficiency Fryer Saves Energy and Oil.

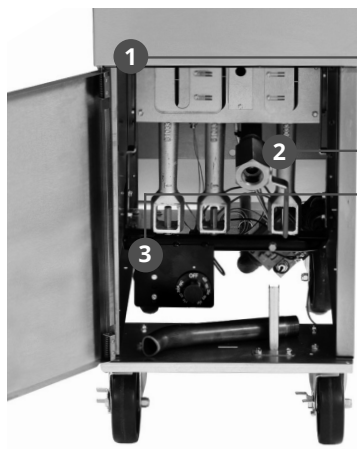

- 1. **High-efficiency.** Exceeds ENERGY STAR® guidelines and qualifies for energy saving rebates.
- 2. **Requires 33% less BTU/hr** than comparable standard models.
- 3. **Millivolt Control** - no electrical hook-up required.

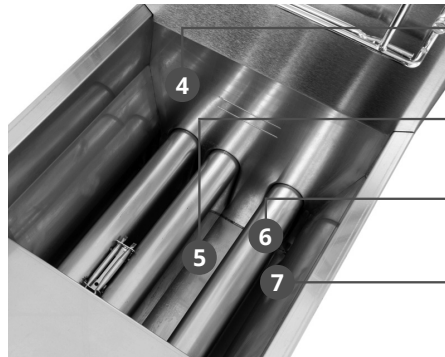

- 4. **22% less oil.** 35-lb. frypot produces as much food as a 45-lb. fryer.
- 5. **Wide cold zone** keeps crumbs and sediment away from cooking areas.
- 6. **6-inch heating tubes** along with a proprietary baffle design deliver superior heat transfer.
- 7. **Insulated frypot** allows for a low idle rate further enhancing energy savings.



- 8. **Reduced flue heat.** 27% Less.
- 9. **Stainless steel** frypot, front door, backsplash and flue.



ESG35T fryers exceed ENERGY STAR® guidelines for high efficiency and are part of the Welbilt EnerLogic™ program



Frymaster[®] ESG35T



TUBE GAS FRYER

- Tube-type frypot design
- Meets ENERGY STAR[®] guidelines
- Qualifies for energy-savings rebates
- Durable temperature probe
- Millivolt controller, no electric connection required
- Thermo-Tube design
- Wide cold zone
- Stainless steel frypot, door, and sides
- Wire form basket hanger and two fry baskets
- 6" (15 cm) adjustable steel legs
- 3/4" (1.9 cm) NPT gas connection



Shown with optional Casters

HIGH EFFICIENCY

ESG35T FRYERS — Without filtration, with stainless steel frypot, door, and sides.

MODEL	MILLIVOLT CONTROLLER	OIL CAPACITY	COOK AREA INCHES	INPUT BTU/HR	SHIPPING WEIGHT
ESG35T	\$4,100	35-lbs.	14 W x 13-3/4 L x 4-1/5 D	70,000	165-lbs.

STANDARD ACCESSORIES

- Legs
- Rack-type Basket Support
- Basket Hanger
- Twin Baskets

GAS LINE TABLE

# OF FRYERS	GAS LINE
1	3/4"

NOTES

- Split pots and basket lifts not available.
- If elevation is between 2,000-6,000 feet, contact local service agent for elevation kits.
- DO NOT CURB MOUNT.
- Any questions or pricing information other than the above should be referred to Customer Service



TUBE GAS FRYER

- High-efficiency Thermo-Tube frypot design
- Thermatron controller, standard
- Electronic ignition
- Robust, RTD, 1° compensating temperature probe
- Large capacity, high performance gas fryers suitable for volume frying
- Stainless steel frypot, door and sides
- Twin baskets
- Wide cold zone, 1-1/4" to 1-1/2" full-port IPS ball-type drain valve
- Combination gas valve with regulator
- Melt cycle and boil out mode



SHOWN WITH OPTIONAL CASTERS

HD FRYERS — Without filtration, stainless steel frypots, door, and sides.

MODEL	THERMATRON CONTROLLER*	CM3.5 CONTROLLER	3000 CONTROLLER	OIL CAPACITY	COOK AREA INCHES	INPUT BTU/HR	SHIPPING WEIGHT
HD150G	\$10,245	\$14,430	\$15,180	50-lbs.	14 x 14 x 3-1/2	100,000	180-lbs.

*Standard with Thermatron controller.

HD50 FRYERS — With filtration, stainless steel frypot(s), door(s), and sides.

MODEL	THERMATRON CONTROLLER*	CM3.5 CONTROLLER	3000 CONTROLLER	OIL CAPACITY	COOK AREA INCHES	INPUT BTU/HR	SHIPPING WEIGHT
CFHD150G	\$18,885	\$24,105	\$24,845	(1) 50-lbs.	(1) 14 x 14 x 3-1/2	(1) 100,000	354-lbs.
SCFHD250G	\$33,770	\$42,135	\$43,610	(2) 50-lbs.	(2) 14 x 14 x 3-1/2	(2) 100,000	575-lbs.
SCFHD350G	\$45,675	\$58,250	\$60,450	(3) 50-lbs.	(3) 14 x 14 x 3-1/2	(3) 100,000	800-lbs.
SCFHD450G	\$57,600	\$74,350	\$77,290	(4) 50-lbs.	(4) 14 x 14 x 3-1/2	(4) 100,000	1,130-lbs.

*Standard with Thermatron controller.

NOTES: Filter price included. | Filter price includes casters. | 4 GPM pump standard.

DESCRIPTION	PRICE
SPECIAL OIL OPTIONS	
External oil discharge — available on built-in filter batteries of 2 or more frypots or a frypot and spreader. Must specify front or rear connection. Front connection comes with 5 ft. washdown hose.	FRONT +\$2,730 REAR +\$2,090
SPREADERS	
Spreader Cabinet—15MC	+\$1,980
NOTE: Call Customer Service for availability and placement.	
BASKET LIFTS	
Basket Lifts	+\$4,595 / FRYPOT
NOTE: Basket lifts not available with Thermatron controller.	

STANDARD ACCESSORIES	
<ul style="list-style-type: none"> • Electronic Ignition • Automatic Melt Cycle • Boil Out Temperature Control • Legs (non-filter models) 	<ul style="list-style-type: none"> • Rack-type Basket Support • Basket Hanger • Twin Baskets • Drain Safety Switch • Casters (filter models)

GAS LINE TABLE	
# OF FRYERS	GAS LINE
1	3/4"
2-4	1"

NOTES

- Split pots not available.
- If elevation is between 2,000-6,000 feet, specify the elevation level. Fryer may not perform at optimum levels above this elevation.
- Casters included in basket lift pricing.
- Any questions or pricing information other than the above should be referred to Customer Service



H55 Gas Fryers

Set the Standard for High-Efficiency, Open-Port Frying

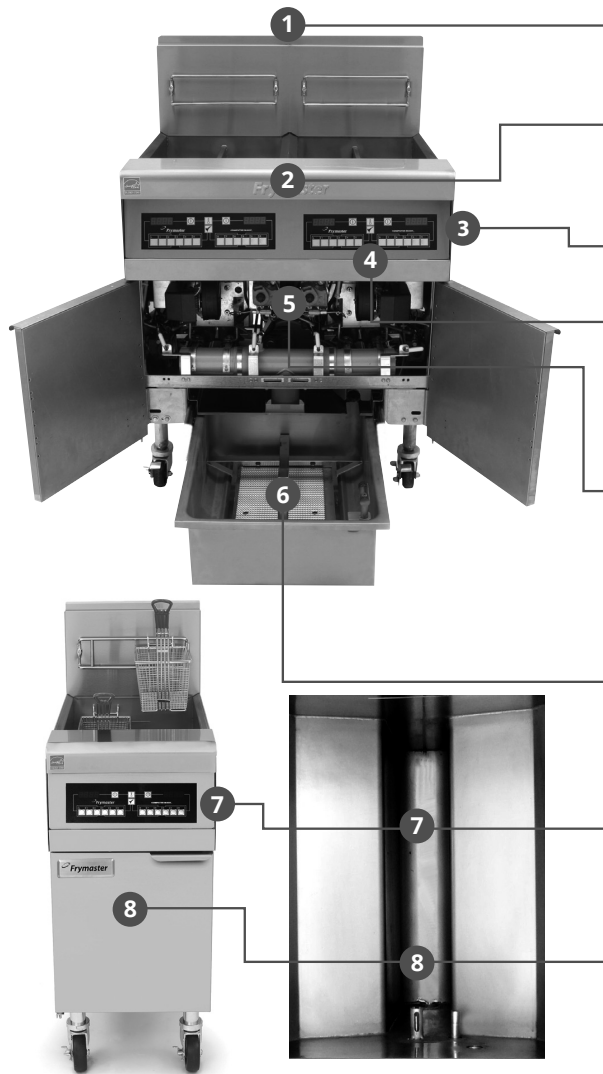

1. **Combine state-of-the-art combustion technology with decades of frying experience** to set a world standard for high-efficiency frying.
2. **Are the industry's first GREEN fryers**, meeting ENERGY STAR® standards long before any standards were established. H55 fryers are the foundation of Frymaster's ever evolving conserving fryer technology.
3. **Qualify for energy-saving rebates.**
4. **Ensure consistent, great-tasting food.** RTD, center-mounted temperature probe and digital controller deliver precise heat responses, safeguarding oil life and producing a uniformly-cooked product. Controller (CM3.5 and SMART4U® 3000) and basket lift options provide additional cooking control. The CM3.5 and 3000 controller options offer cooking compensation.
5. **Have a renowned infrared burner and blower system** that delivers an ultra-refined air-gas mixture so the fryer operates well in any gas application.
 - High altitudes
 - Sub-optimal air circulation environments
 - When gas heating quality is diminished
6. **Offer easy-to-operate, quick, convenient and reliable filtration options** that maintain food quality, extend the useful cooking life of oil, and save money. Built-in filtration supports a regular program of filtration proven to dramatically extend oil life, saving thousands of dollars annually on oil costs.
7. **Offer standard features that add convenience and ease of use.**
 - Open frypot is easy to clean
 - Electronic ignition (no pilot to light), melt cycle mode, and boil-out mode
8. **Protect purchases with an unmatched 7-Year Warranty** that covers the entire combustion chamber (frypot, infrared burners, and combustion components).

H55 fryers have been tested by time and are trusted by operators worldwide.



Frymaster® H55



OPEN POT GAS FRYER

- Open pot design (split or full) is easy to clean
- CM3.5 controller, standard
- Stainless steel frypot, door, and sides
- Center-mounted, RTD, 1° compensating temperature probe
- Deep cold zone with forward-sloping bottom and 1-1/4" IPS full-port, ball-type drain valve
- Infrared burners ensure state-of-the-art heat transfer
- Electronic ignition
- Automatic melt cycle and boil out temperature control
- Twin baskets
- Drain safety switch



SHOWN WITH OPTIONAL CASTERS

HIGH EFFICIENCY

H55 FRYER — Without filtration, with stainless steel frypot, door, and sides.

MODEL	DIGITAL TIMER CONTROLLER	CM3.5 CONTROLLER*	OIL CAPACITY	COOK AREA INCHES	INPUT BTU/HR	SHIPPING WEIGHT
PH155	\$12,745	\$15,730	50-lbs.	14 W x 15 L x 4-1/2	80,000	202-lbs.

*Standard with CM3.5 controller.

H55 FRYER BATTERIES — With filtration, stainless steel frypot(s), door(s), and sides.

MODEL	DIGITAL TIMER CONTROLLER	CM3.5 CONTROLLER*	OIL CAPACITY	COOK AREA INCHES	INPUT BTU/HR	SHIPPING WEIGHT
FPH155	\$24,090	\$27,025	(1) 50-lbs.	(1) 14 W x 15 L x 4-1/2 D	(1) 80,000	306-lbs.
FPPH255	\$37,830	\$43,740	(2) 50-lbs.	(2) 14 W x 15 L x 4-1/2 D	(2) 80,000	492-lbs.
FPPH355	\$51,745	\$60,590	(3) 50-lbs.	(3) 14 W x 15 L x 4-1/2 D	(3) 80,000	671-lbs.
FPPH455	\$65,665	\$77,465	(4) 50-lbs.	(4) 14 W x 15 L x 4-1/2 D	(4) 80,000	881-lbs.

*Standard with CM3.5 controller.

NOTES: Filter price included. | Price includes casters.

DESCRIPTION	PRICE
SPECIAL OIL OPTIONS	
External oil discharge — available on built-in filter batteries of 2 or more frypots or a frypot and spreader. Must specify front or rear connection. Front connection comes with 5 ft. washdown hose.	FRONT +\$2,730 REAR +\$2,090
SPREADERS	
Spreader Cabinet—15MC	+\$2,405
NOTE: Call Customer Service for availability and placement.	
BASKET LIFTS	
Basket Lifts	+\$4,595 / FRYPOT
Tandem basket lifts	+\$190 / FRYPOT
NOTE: Basket lifts only available with CM3.5	
FRYPOT OPTIONS	
Split Frypot(s)	+\$3,440 / FRYPOT

STANDARD ACCESSORIES

- Electronic Ignition
- Automatic Melt Cycle
- Boil Out Temperature Control
- Legs (non-filter models)
- Rack-type Basket Support
- Basket Hanger
- Twin Baskets
- Casters (filter models only)

GAS LINE TABLE

# OF FRYERS	GAS LINE
1	3/4"
2-3	1"
4	1" (x2)

NOTES

- Legs cannot be ordered on the FPH155 per Agency standards.
- Standard supplies for all filter systems consist of sample packages of filter powder and paper, one filter brush, and one clean-out rod.
- Call Customer Service — Toll Free 1-800-221-4583 or refer to manual provided with fryer for correct sizing information including high elevation installations.
- If elevation is between 5,000-10,000 feet, specify the elevation level. Fryer may not perform at optimum levels above

this elevation.

- DO NOT CURB MOUNT.
- Casters included in basket lift pricing.
- Any questions or pricing information other than the above should be referred to Customer Service



TUBE GAS FRYER



- Thermo-Tube frypot design
- ENERGY STAR® qualified
- Eligible for energy-saving rebates
- Low flue temperature (<550°F/287°C)
- 3000 controller, standard
- Electronic ignition
- Wide cold zone
- Built-in filtration (batteries only)
- 8 GPM filter pump
- Heat tape wrapped filter lines
- Drain safety switch
- Drain flush, 1-1/2" drain valve, 3" drain
- Stainless steel frypot, door, and sides
- Casters
- 11" plate shelf with marine edge

LHD65 FRYERS — Without filtration, with stainless steel frypot, door, and sides.

MODEL	THERMATRON CONTROLLER	3000 CONTROLLER*	OIL CAPACITY	COOK AREA INCHES	INPUT BTU/HR	SHIPPING WEIGHT
LHD165	\$14,815	\$19,945	100-lbs.	18 W x 18 L x 5-3/4 D	105,000	260-lbs.

LHD65 FRYER BATTERIES — With filtration, stainless steel frypots, doors, and sides.

MODEL	THERMATRON CONTROLLER	3000 CONTROLLER*	OIL CAPACITY	COOK AREA INCHES	INPUT BTU/HR	SHIPPING WEIGHT
FPLHD265	\$45,565	\$55,825	(2) 100-lbs.	(2) 18 W x 18 L x 5-3/4 D	(2) 105,000	750-lbs.
FPLHD365	\$62,130	\$77,510	(3) 100-lbs.	(3) 18 W x 18 L x 5-3/4 D	(3) 105,000	1,100-lbs.

*Standard with 3000 controller. Optional 3010 controller available. NOTES: Filter price included. | Price includes casters.

RECOMMENDED STANDARD ACCESSORY PACKAGES

Fryers do not come with traditional accessories, these must be ordered. See recommended accessory packages below.

PART #	DESCRIPTION
STANDARD FRYING	
8102235	Basket Support Rack
8235859	Basket Hanger With Flue Deflector(s)
8030304	Twin Size Baskets
BONE-IN CHICKEN	
8103066	L-Basket Support Rack
8235801	Flue Deflector

Recommended Standard Accessories can be ordered per frypot.
Example: FPLHD265 — one standard frying package and one bone-in chicken package.

DESCRIPTION	PRICE
-------------	-------

SPECIAL OIL OPTIONS

External oil discharge — available on built-in filter batteries of 2 or more frypots or a frypot and spreader. Must specify front or rear connection. Front connection comes with 5 ft. washdown hose.

FRONT +\$2,730
REAR +\$2,090

GAS MANIFOLD REQUIREMENTS

1" Rear Gas Manifold (Per Fryer)	With Shut-Off Valve	+\$195
	Without Shut-Off Valve	Standard

GAS LINE TABLE

# OF FRYERS	GAS LINE WITHOUT FILTER	GAS LINE WITH FILTER
1	3/4"	N/A
2-3	N/A	1"

NOTES

- Split pots and basket lifts not available.
- If elevation is between 2,000-6,000 feet, specify the elevation level. Fryer may not perform at optimum levels above this elevation.
- Any questions or pricing information other than the above should be referred to Customer Service

PART #	DESCRIPTION	SIZE INCHES	APPLICABLE MODELS	PRICE
8030099	Basket, Full Size (Can be used with TANDEM basket lifts)	12-3/8 W x 12-7/8 L x 5-1/4 D	H55, HD50	\$615
8030148	Basket, Full Size (Can be used with TANDEM basket lifts)	17-1/2 W x 16-3/4 L x 5-7/8 D	LHD65	\$640
8030357	Basket, Triplet Size	4-1/2 W x 13-1/4 L x 6 D	H55, HD50	\$420
8030427	Basket, Triplet Size	5-5/8 W x 15-7/8 L x 7-1/4 D	LHD65	\$445
8030271	Basket, Twin Size	5-7/8 W x 12-5/8 L x 6-5/8 D	H55, HD50G, ESG35T	\$420
8030304	Basket, Twin Size	8-3/4 W x 16-3/4 L x 6 D	LHD65	\$420
8102793	Basket Hanger	12-3/4 W x 3-1/2 L x 1-1/2 D	H55, ESG35T	\$295
2101595	Basket Hanger — Over The Flue	15-3/8 W x 6-5/8 H	HD50G (singles) Call customer service for batteries	\$255
8235859	Basket Hanger With Flue Deflector	20 W x 7 H	LHD65	\$295
8030132	Basket Support Rack Type — Full Pot	12-1/2 W x 13-3/4 D	H55	\$295
8030133	Basket Support Rack Type — Split Pot	6 W x 14 D	H55	\$265
8102235	Basket Support Rack Type	17-3/8 W x 17-5/8 D	LHD65	\$425
8030273	Basket Support Rack Type	13-1/2 W x 13-1/4 D	HD50	\$295
8030442	Basket Support Rack Type	13-1/2 W x 11-1/4 D	ESG35T	\$295
8030277	Basket Support Rack, Fine Mesh	13-1/2 W x 13-1/4 D	HD50	\$355
8030149	Basket Support Rack, Fine Mesh	17 W x 17 D	LHD65	\$420
8030136	Basket Support Screen Type With Handle – Full Pot Only	12-1/2 W x 13-3/4 D	H55	\$355
8103066	L-Basket Support Rack	17-5/8 W x 17-5/8 D	LHD65	\$495
8030429	Brush L-Shaped, Tampico	21 L, 2 Diameter	All Models	\$205
8030278	Brush L-Shaped, Teflon	26-3/4 L, 1 Diameter	All Models	\$255
	Casters – Set of Four Call customer service to specify fryer models		All Models	\$685
8230619	Chicken/Fish Plate — Full Pot (Not Available For Split Pot)	12-3/8 W x 14 D	H55	\$770
2208963	Chicken/Fish Tray — Full Pot	13-5/8 W x 13-1/2 D	HD50	\$760
8030197	Clean-Out Rod	27 L	All Models (except FQ)	\$265
8239416	Cover — Split Pot		H55	\$595
8239426	Cover — Stainless Steel — Full Pot	15-1/8 W x 20-1/4 D	H55	\$595
1061637	Cover — Stainless Steel — Full Pot	13-1/2 W x 21-3/8 D	HD50, ESG35T	\$595
1062734	Cover — Stainless Steel w/Basket Lifts	14-1/4 W x 20-1/2 D	HD50	\$555
8233938	Crumb Scoop Cold Zone	1-1/4 W x 6-1/2 D x 22-3/4 L	All Models	\$295
8030059	Fish Scoop	8-1/8 W x 8-1/2 D with 17-3/8 L handle	All Models	\$305
8030446	Fish Skimmer	6 square with 13-5/8 L insulated handle, no hooks	All Models	\$295
9103557	Flue Deflector	12-1/2 W x 6-7/8 H	H55	\$315
8235801	Flue Deflector	20 W x 9-1/2 H	LHD65	\$295
	Foam Deck Basket Banger		H55, HD50	\$480 / FRYPOT
8030293	Gloves, Black Safety		All Models	\$185
8103169	Legs — Set of Four — Nickel Call customer service to specify fryer models	6 H		\$685
8101205	Legs — Set of Four — Stainless Steel Call customer service to specify fryer models	6 H		\$685
	Legs — Set of Four — Stainless Steel Call customer service to specify fryer models	8-1/2 H	H55	\$685
8100088	Quick Disconnect with 1" Gas Line Systems Only	36 L	H55, LHD65	\$1,320
8100085	Quick Disconnect with 1" Gas Line Systems Only	48 L	H55, LHD65	\$1,410
8061701	Quick Disconnect with 3/4" Gas Line Single Units	36 L	H55, LHD65	\$1,065
8061700	Quick Disconnect With 3/4" Gas Line Single Units	48 L	H55, LHD65	\$1,160
8030132	Rack Type Basket Support — Full Pot	12-1/2 W x 13-3/4 D	H55	\$295
8030103	Sediment Tray — Full Pot	12-1/2 W x 14 L x 6-1/2 D	H55	\$1,005
8030107L	Sediment Tray — Split Pot Left	5-7/8 W x 14 L x 6-1/2 D	H55-2	\$760
8030108R	Sediment Tray — Split Pot Right	5-7/8 W x 14 L x 6-1/2 D	H55-2	\$760
1064136	Sediment Tray	13-1/2 W x 13-3/4 D	HD50	\$1,035
8236559	Splash Shield	20 D x 6-1/4 H	H55	\$595

PART #	DESCRIPTION	SIZE INCHES	APPLICABLE MODELS	PRICE
8233225	Splash Shield	21-1/2 D × 13 H	HD50	\$355
8235789	Splash Shield	18 D × 14 H	LHD65	\$425
2109291	Top Connecting Strip	2-1/4 W × 20-1/2 D	H55	\$370
2102681	Top Connecting Strip	2 W × 21-3/8 D	HD50	\$370
2105086	Top Connecting Strip	2 W × 23-5/8 D	LHD65	\$370



OCF30™ Series Gas Fryers

40% Less Oil, 10% Less Energy,
Outstanding Results

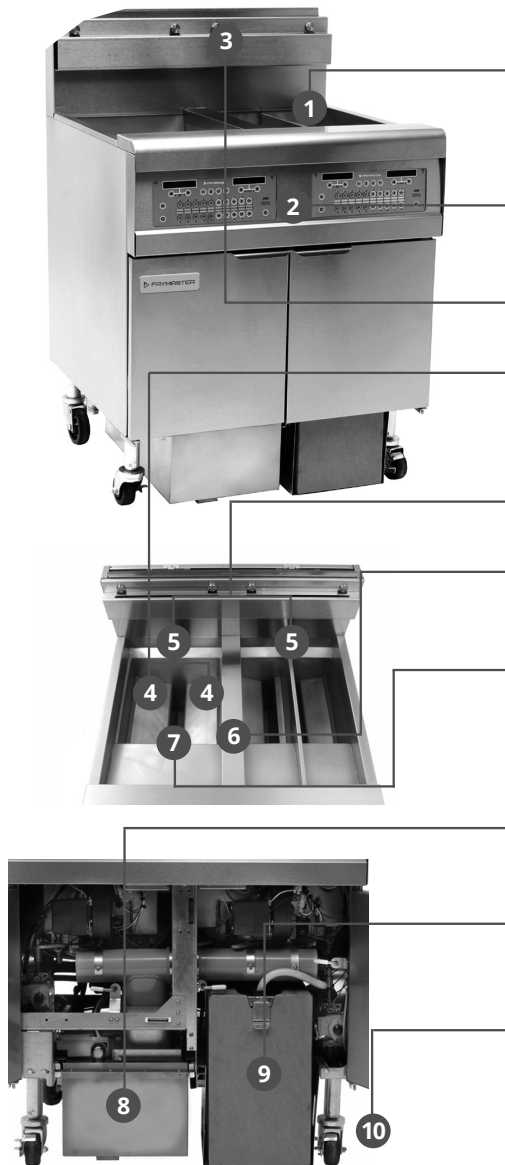

1. **30-lb. open frypot design** requires 40% less oil and ensures quick and easy cleaning. Saves money, time and labor.
2. **SMART4U® 3000 controller** helps control food and oil quality, oil life, and equipment performance.
3. **Sturdy basket hangers** are durable and easy to clean.
4. **State-of-the-art combustion** fuels efficiency. ENERGY STAR® rated infrared heat transfer qualifies fryers for energy-saving rebates.
5. **Robust product line** offers full and split frypots.
6. **Independent frypot construction** allows convenient frypot repairs in the field if needed.
7. **High limit auto reset** requires no tools or operator intervention and an **audible alarm** alerts if a second drain valve is opened.
8. **Built-in Filtration** preserves oil life and ensures consistent, great-tasting food.
9. **Oil Attendant® Auto Fill Option** senses the oil level and adds oil as needed from an in-cabinet supply.
10. **Adjustable leveling casters** accommodate all kitchen designs and floor types.



OCF30G fryers meet ENERGY STAR® guidelines for high efficiency, and all OCF30G fryers are part of the Welbilt EnerLogic™ program.



Frymaster[®] OCF30G



OPEN POT GAS FRYER

- Open pot design (split or full) is easy to clean
- 30-lb. frypot with open pot design requires 40% less oil to cook as much food as frypots almost twice its size, while using 10% less energy and producing less waste
- 3000 controller has operation management features that monitor and help control food and oil quality, oil life, and equipment performance. Has 20 programmable cook buttons and auto adjusts cook time to load size
- Innovative safety features offer proprietary advantages over other fryers
- Durable, infrared burners
- Center-mounted RTD, 1st action thermostat
- Built-in filtration with rear oil flush puts filtration where it's most convenient to use, right in the fryer
- Stainless steel frypot, door, and cabinet sides
- Adjustable casters
- Drain safety switch



OCF30 FRYER — With filtration, manual top off stainless steel frypot, door, and sides.

MODEL	3000 CONTROLLER*	OIL CAPACITY	COOK AREA INCHES	INPUT BTU/HR	SHIPPING WEIGHT
FPGL130C	\$29,410	30-lbs.	13 W x 14 L x 3-3/4 D	70,000	265-lbs.

*Standard with 3000 controller. | Can substitute 3010 controller for no additional cost.

OCF30 FRYER BATTERIES — With filtration, Automatic Top Off (ATO) stainless steel frypots, doors, and sides.

MODEL	3000 CONTROLLER*	OIL CAPACITY	COOK AREA INCHES	INPUT BTU/HR	SHIPPING WEIGHT
FPGL230CA	\$50,510	(2) 30-lbs.	(2) 13 W x 14 L x 3-3/4 D	(2) 70,000	544-lbs.
FPGL330CA	\$69,270	(3) 30-lbs.	(3) 13 W x 14 L x 3-3/4 D	(3) 70,000	723-lbs.

*Standard with 3000 controller. Can substitute 3010 controller for no additional cost.

NOTE: Casters included in pricing.

DESCRIPTION	PRICE
SPREADERS	
Spreader Cabinet—15MC	+\$2,405
NOTE: Call Customer Service for availability and placement.	
BASKET LIFTS	
Basket Lifts	+\$4,595 / FRYPOT
Tandem basket lifts	+\$190 / FRYPOT
FRYPOT OPTIONS	
Split Frypot	+\$5,160 / FRYPOT
SPECIAL OIL OPTIONS	
Bulk Oil (dispose and fresh fill)* (Not Available For FPGL130C)	+\$2,865
Semi-solid / solid shortening*	+\$4,545

*Must be requested at time of order.

STANDARD ACCESSORIES

- Built-in Filtration with ATO
- Casters
- Rack-type Basket Support
- ATO (except FPGL130C)
- Basket Hanger
- Twin Baskets
- Filter Starter Kit
- Jug in Box (JIB) Holder

GAS LINE TABLE

# OF FRYERS	GAS LINE
1	3/4"
2-3	1"

NOTE: 1-1/2" gas supply line required. Gas inlet size (I.D.) should be no smaller than that provided for connection to the fryers. See service manual and/or plumbing codes for proper pipe sizing.

NOTES

- 5 ft. grounded cordset provided.
- If elevation is between 5,000-10,000 feet, specify the elevation level. Fryer may not perform at optimum levels above this elevation.
- DO NOT CURB MOUNT.
- Casters included in basket lift pricing.
- Any questions or pricing information other than the above should be referred to Customer Service



Frymaster® 1814G



TUBE GAS FRYER

- Lane controller has programmable cook buttons and features that make it easy to produce consistent, great tasting food
- Thermo-Tube heat-transfer system efficiently transfers energy into the oil, saving energy and extending oil life
- Robust, RTD, 1° compensating temperature probe
- Wide cold zone traps sediment away from cooking area, safeguarding oil
- Stainless steel frypot, door, and sides
- Sturdy stainless steel over-the-flue basket hangers
- Three twin baskets per frypot
- Drain safety switch



OIL CONSERVING

1814 FRYER — Without filtration with stainless steel frypot, door, and sides.

MODEL	DIGITAL TIMER CONTROLLER	CM3.5 CONTROLLER	LANE CONTROLLER*	OIL CAPACITY	COOK AREA INCHES	INPUT BTU/HR	SHIPPING WEIGHT
11814G	\$13,530	\$15,530	\$17,140	63-lbs.	18 W x 14 L x 3-3/4 D	119,000	255-lbs.

*Standard with Lane controller. 3000 and 3010 controller can be substituted for Lane controller at no cost.

1814 FRYERS — With filtration with stainless steel frypot(s), door(s), and sides.

MODEL	DIGITAL TIMER CONTROLLER	CM3.5 CONTROLLER	LANE CONTROLLER*	OIL CAPACITY	COOK AREA INCHES	INPUT BTU/HR	SHIPPING WEIGHT
11814GF	\$29,285	\$31,290	\$32,885	(1) 63-lbs.	(1) 18 W x 14 L x 3-3/4 D	(1) 119,000	390-lbs.
21814GF	\$44,160	\$48,135	\$51,355	(2) 63-lbs.	(2) 18 W x 14 L x 3-3/4 D	(2) 119,000	645-lbs.
31814GF	\$59,040	\$65,000	\$69,835	(3) 63-lbs.	(3) 18 W x 14 L x 3-3/4 D	(3) 119,000	900-lbs.

*Standard with Lane controller. 3000 and 3010 controller can be substituted for Lane controller at no cost.

DESCRIPTION	PRICE
SPREADERS	
Spreader Cabinet—20MC	+\$2,695
NOTE: Call Customer Service for availability and placement.	
BASKET LIFTS	
Basket Lifts	+\$4,595 / FRYPOT
SPECIAL OIL OPTIONS	
External oil discharge — available on built-in filter batteries of 2 or more frypots or a frypot and spreader. Must specify front or rear connection. Front connection comes with 5 ft. washdown hose.	FRONT +\$2,730 REAR +\$2,090
Bulk oil (dispose and fresh fill) on batteries with built-in filtration*	+\$4,520

*Must be requested at time of order.

STANDARD ACCESSORIES

- Electronic Ignition
- Twin Baskets
- Rack-type Basket Supports
- Basket Hangers
- Legs (non-filter models)
- Drain Safety Switch*
- Filter Starter Kit*
- Casters*
- 8 GPM Pump*

*Available on filter models

GAS LINE TABLE

# OF FRYERS	GAS LINE
1	3/4"
2-3	1"

NOTE: 1-1/2" gas supply line required. Gas inlet size (I.D.) should be no smaller than that provided for connection to the fryers. See service manual and/or plumbing codes for proper pipe sizing.

NOTES

- Split pots not available.
- If elevation is between 2,000-6,000 feet, specify the elevation level. Fryer may not perform at optimum levels above this elevation.
- DO NOT CURB MOUNT.
- Casters included in basket lift pricing.
- Any questions or pricing information other than the above should be referred to Customer Service

PART #	DESCRIPTION	SIZE INCHES	APPLICABLE MODELS	PRICE
8030099	Basket, Full Size (Can be used with TANDEM basket lifts)	12-3/8 W x 12-7/8 L x 5-1/4 D	OCF30G	\$615
8030435	Basket, Full Size (Cannot be used with basket lifts)	17-1/2 W x 12-7/8 L x 6-1/8 D	1814G	\$600
8030438	Basket, Triplet Size	4-1/4 W x 13-1/4 L x 5-1/2 D	OCF30G	\$420
8030271	Basket, Twin Size	5-7/8 W x 12-5/8 L x 6-5/8 D	OCF30G, 1814G	\$420
8030436	Basket, Chicken	17-3/4 W x 12-1/4 L x 11 D	1814G	\$1,040
8030437	Basket, Dual	8 W x 12-5/8 L x 7 D	1814G	\$440
8030357	Basket, Triplet	4-1/2 W x 13-1/4 L x 6 D	1814G	\$420
2308165	Basket Hanger	15-3/8 W x 5 H	OCF30G (single frypot)	\$295
2307495	Basket Hanger	31 W x 5 H	OCF30G (two frypots)	\$450
2307497	Basket Hanger	46-1/2 W x 5 H	OCF30G (three frypots)	\$665
8237770	Basket Hanger — Over The Flue	20 W x 8-1/2 H	11814G (single frypot)	\$295
8237771	Basket Hanger — Over The Flue	39-3/4 W x 8-1/2 H	21814G (two frypots)	\$450
8030375	Basket Support Rack Type — Full Pot	11-7/8 W x 13-1/2 D	OCF30G	\$305
8030372	Basket Support Rack Type— Split Pot	5-7/8 W x 13-1/2 D	OCF30G	\$265
8030380	Basket Support Rack Type — Full Pot	13-5/8 W x 18 D	1814G	\$295
8030429	Brush L-Shaped, Tampico	21 L, 2 Diameter	All Models	\$205
8030278	Brush L-Shaped, Teflon	26-3/4 L, 1 Diameter	All Models	\$255
	Casters – Set of Four Call customer service to specify fryer models		All Models	\$685
8238066	Chicken/Fish Plate — Full Pot	12 W x 13-3/8 D	OCF30G	\$760
2208966	Chicken/Fish Plate — Full Pot	18 W x 13-5/8 D	1814G	\$830
8030197	Clean-Out Rod	27 L	All Models	\$265
8238898	Cover — Split Pot		OCF30G	\$595
8238897	Cover — Stainless Steel — Full Pot	14-5/8 W x 21 D	OCF30G	\$595
1081872	Cover — Stainless Steel — Full Pot	21-3/8 W x 19-1/2 D	1814G	\$595
8233938	Crumb Scoop Cold Zone	1-1/4 W x 6-1/2 D x 22-3/4 L	All Models	\$295
8030059	Fish Scoop	8-1/8 W x 8-1/2 D with 17-3/8 L handle	All Models	\$305
2400916	Fish plate, wet battered		1814G	\$835
8030446	Fish Skimmer	6 square with 13-5/8 L insulated handle, no hooks	All Models	\$295
	Foam Deck Basket Banger		OCF30G, 1814G	\$480 / FRYPOT
8030293	Gloves, Black Safety		All Models	\$185
8103169	Legs – Set of Four – Nickel Call customer service to specify fryer models	6 H		\$685
	Legs – Set of Four – Stainless Steel Call customer service to specify fryer models	6 H		\$685
8100088	Quick Disconnect with 1" Gas Line Systems Only	36 L	OCF30G, 1814G	\$1,320
8100085	Quick Disconnect with 1" Gas Line Systems Only	48 L	OCF30G, 1814G	\$1,410
8061701	Quick Disconnect with 3/4" Gas Line Single Units	36 L	OCF30G, 1814G	\$1,065
8061700	Quick Disconnect With 3/4" Gas Line Single Units	48 L	OCF30G, 1814G	\$1,160
8239145	Mobile JIB Holder	10-1/2 W x 12-1/4 D x 8-3/8 H	OCF30	\$905
8030511	Sediment Tray — Full Pot	11-7/8 W x 13-3/8 L x 6-1/2 D	OCF30G	\$1,035
8237619	Splash Shield	21-3/8 D x 7-7/8 H	1814G	\$595
8238224	Splash Shield	19-1/2 D x 11-3/4 H	OCF30G	\$595
2102681	Top Connecting Strip	2 W x 21-3/8 D	1814G	\$370
8235810	Top Connecting Strip	1-7/8 W x 20-3/4 D	OCF30G	\$595

Gas Fryers

Fingertip Filtration Plus:

40% Less Oil, 10% Less Energy, Outstanding Results



- 30-lb and 60-lb open frypot design** requires 40% less oil and ensures quick and easy cleaning. Saves money, time and labor.
- Independent frypot construction** allows convenient frypot repairs in the field, if needed.
- State-of-the-art combustion** fuels efficiency. Infrared heat transfer qualifies fryers for energy-saving rebates.
- FQ4000 easyTouch® Controller** has operation management features that monitor and help control food quality, oil life, and equipment performance. Offers configurable and customizable recipe management, and connectivity compatible.

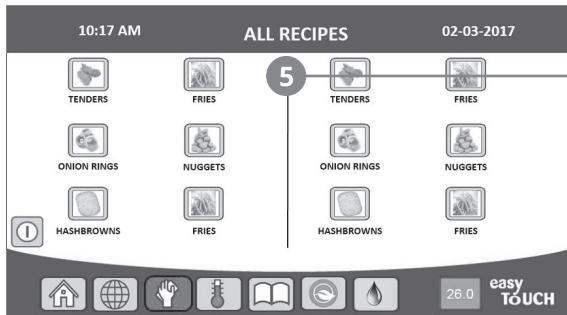

- Fingertip, closed cabinet, fully-automatic filtration** starts with easy touch operating actions.
 - Safe technology ensures only one frypot can drain at a time. Filtration is as easy as pushing a button.
 - The filter pump agitates the oil in the frypot before draining to lift the crumbs from the bottom of the frypot, aiding their removal.
 - The blower cools the frypot when draining.
 - The frypot begins heating as soon as a safe level of oil returns to the frypot to speed return to set temperature.
 - The pump is protected by a pressure relief valve for bulk oil systems.

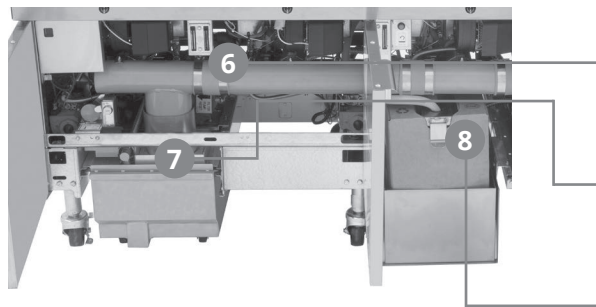

- Optional Oil Quality Sensor (OQS)** monitors the oil's health and advises when to discard. No more guesswork.
- Innovative safety features** offer proprietary advantages over other fryers that prevent simultaneous vat filtrations.
- Automatic Top-Off (ATO) feature** senses the oil level and adds oil as needed from an in-cabinet supply.



FilterQuick® fryers exceed ENERGY STAR® guidelines for high-efficiency and are part of the Welbilt EnerLogic® program.





Frymaster® FQG30 FILTERQUICK®



OPEN POT GAS FRYER



- 30-lb. frypot with open pot design requires 40% less oil to cook as much food as frypots almost twice its size, while using 10% less energy and producing less waste
- Frying area 13" W × 14" L × 3-3/4" D (33 × 36 × 9.5 cm)
- Auto Top Off — automatically replenishes oil from Jug in box (JIB) conveniently located inside the fryer cabinet
- FilterQuick easyTouch® controller has operation management features that monitor and help control food and oil quality, oil life, and equipment performance. Has 20 programmable cook buttons and auto adjusts cook time to load size
- Closed-cabinet, fully-automatic filtration with rear oil flush, puts filtration where it's most convenient to operate, on the front of the fryer
- Optional integrated Oil Quality Sensor monitors the health of the oil and indicates with great precision the true point that oil needs to be discarded
- Innovative safety features offer proprietary advantages over other fryers — prevent simultaneous vat filtrations
- Independent frypot construction of batteries makes it easy to repair or replace a frypot while maintaining continuous operation
- Center-mounted RTD, 1° action thermostat
- Stainless steel frypot, door, and sides
- Adjustable casters
- Bottom splash shield

FILTERQUICK 30 FRYER BATTERIES — With filtration, FQ4000 easyTouch controller, Automatic Top Off (ATO), stainless steel frypots, doors, and sides.

MODEL	FQ4000 CONTROLLER*	OIL CAPACITY	COOK AREA INCHES	INPUT BTU/HR	SHIPPING WEIGHT
2FQG30U W/ EASYTOUCH	\$54,535	(2) 30-lbs.	(2) 13 W × 14 L × 3-3/4 D	(2) 70,000	575-lbs.
3FQG30U W/ EASYTOUCH	\$71,825	(3) 30-lbs.	(3) 13 W × 14 L × 3-3/4 D	(3) 70,000	723-lbs.
4FQG30U W/ EASYTOUCH	\$93,905	(4) 30-lbs.	(4) 13 W × 14 L × 3-3/4 D	(4) 70,000	980-lbs.

*with FilterQuick FQ4000 easyTouch controller. NOTE: Price includes casters.

DESCRIPTION	PRICE
SPECIAL OIL OPTIONS	
Semi-solid / solid shortening*	+\$4,545
Front oil discharge (Precludes bulk rear oil discharge)	SPECIFY WHEN ORDERED
Oil Quality Sensor*	+\$4,105
*Must be requested at time of order. NOTE: Call Customer Service before ordering.	
SPREADERS	
Spreader Cabinet—15MC	+\$2,405
NOTE: Call Customer Service for availability and placement.	
BASKET LIFTS	
Basket Lifts	+\$4,595 / FRYPOT

STANDARD ACCESSORIES	
• FilterQuick Filtration with ATO	• Twin Baskets
• Casters	• Filter Starter Kit
• Rack-type Basket Support	• 4 GPM Pump
• Bottom Splash Shield	• Jug in Box (JIB) Holder
• Covers	• Bulk Oil (dispose and fresh fill)
• Basket Hanger	

# OF FRYERS	GAS LINE
2-4	1"

NOTE: 1-1/2" gas supply line required. Gas inlet size (I.D.) should be no smaller than that provided for connection to the fryers. See service manual and/or plumbing codes for proper pipe sizing.

NOTES

- Split pots not available.
- Oil Management Package included at no extra charge. Includes set up for bulk oil*
- 5 ft. grounded cordset provided.
- If elevation is between 5,000-10,000 feet, specify the elevation level. Fryer may not perform at optimum levels above this elevation.
- DO NOT CURB MOUNT.
- Casters included in basket lift pricing.
- Any questions or pricing information other than the above should be referred to Customer Service



Frymaster® FQG60 FILTERQUICK®



TUBE GAS FRYER

- FQ4000 easyTouch® controller makes cooking and filtering simple and intuitive — fry station management features monitor and help control food and oil quality, oil life, and equipment performance
- Thermo-Tube heat-transfer system efficiently transfers energy into the oil, saving energy and extending oil life
- Robust, RTD 1° compensating temperature probe
- Stainless steel frypot, door, and sides
- Sturdy stainless steel basket hangers
- Closed cabinet, automatic filtration with rear oil flush puts filtration where it's most convenient to operate, right on the front of the fryer
- Innovative safety features offer proprietary advantages over other fryers — prevent simultaneous vat filtrations



FILTERQUICK

FILTERQUICK 60 FRYER BATTERIES — With filtration, FQ4000 easyTouch controller, Automatic Top Off (ATO), stainless steel frypot(s), door(s), and sides.

MODEL	FQ4000 CONTROLLER*	OIL CAPACITY	COOK AREA INCHES	INPUT BTU/HR	SHIPPING WEIGHT
1FQG60T W/ EASYTOUCH	\$41,185	(1) 63-lbs.	(1) 18 W x 14 L x 3-3/4 D	(1) 119,000	295-lbs.
2FQG60T W/ EASYTOUCH	\$60,770	(2) 63-lbs.	(2) 18 W x 14 L x 3-3/4 D	(2) 119,000	390-lbs.
3FQG60T W/ EASYTOUCH	\$80,340	(3) 63-lbs.	(3) 18 W x 14 L x 3-3/4 D	(3) 119,000	645-lbs.

*Standard with FQ4000 easyTouch Controller.

DESCRIPTION	PRICE
SPECIAL OIL OPTIONS	
External oil discharge — available on built-in filter batteries of 2 or more frypots or a frypot and spreader. Must specify front or rear connection. Front connection comes with 5 ft. washdown hose.	FRONT +\$2,730 REAR +\$2,090
Bulk oil (dispose and fresh fill) on batteries with built-in filtration*	+\$4,520
Automatic Top Off (ATO) with side saddle* Requires additional 3" space.	+\$4,685
Automatic Top Off (ATO) with external 6 foot hose (no side saddle)*	+3,015
Semi-solid / solid shortening*	+\$4,545
Oil Quality Sensor*	+\$4,105

*Must be requested at time of order.
NOTE: Call Customer Service before ordering.

SPREADERS	
Spreader Cabinet—20MC	+\$2,695
NOTE: Call Customer Service for availability and placement.	
BASKET LIFTS	
Basket Lifts	+\$4,595 FRYPOT

STANDARD ACCESSORIES	
<ul style="list-style-type: none"> • Electronic Ignition • Twin Baskets • Rack-type Basket Supports • Basket Hangers 	<ul style="list-style-type: none"> • Drain Safety Switch • Filter Starter Kit • Casters • 8 GPM Pump
GAS LINE TABLE	
# OF FRYERS	GAS LINE
1	3/4"
2-3	1"

NOTE: 1-1/2" gas supply line required. Gas inlet size (I.D.) should be no smaller than that provided for connection to the fryers. See service manual and/or plumbing codes for proper pipe sizing.

NOTES

- Split pot not available.
- If elevation is between 2,000-6,000 feet, specify the elevation level. Fryer may not perform at optimum levels above this elevation.
- DO NOT CURB MOUNT.
- Casters included in basket lift pricing.
- Any questions or pricing information other than the above should be referred to Customer Service



Frymaster® FQG80 FILTERQUICK®



TUBE GAS FRYER



- FQ4000 easyTouch® controller makes cooking and filtering simple and intuitive. Fry station management features monitor and help control food and oil quality, oil life, and equipment performance
- Closed-cabinet automatic filtration with rear oil flush puts filtration where it's most convenient to operate, right on the front of the fryer.
- Thermo-tube heat transfer system efficiently transfers energy into the oil, saving energy and extending oil life
- 8GPM pump with 1/3 HP motor
- Optional integrated oil quality sensor monitors the health of the oil and indicates with great precision the true point that oil needs to be discarded
- Innovative safety features offer proprietary advantages over other fryers - prevent simultaneous vat filtrations
- Stainless steel frypots, doors, and sides
- Front oil discharge with 6ft washdown hose

FILTERQUICK 80 FRYER BATTERIES — With filtration, FQ4000 easyTouch controller, stainless steel frypots, doors, and sides.

MODEL	FQ4000 CONTROLLER*	OIL CAPACITY	COOK AREA INCHES	INPUT BTU/HR	SHIPPING WEIGHT
2FQG80T	\$69,980	(2) 80-lbs.	(2) 18 W x 18 L x 4-3/4 D	(2) 125,000	510-lbs.
3FQG80T	\$87,350	(3) 80-lbs.	(3) 18 W x 18 L x 4-3/4 D	(3) 125,000	814-lbs.

DESCRIPTION	PRICE
SPECIAL OIL OPTIONS	
Semi-solid / solid shortening*	+\$4,545
Oil Quality Sensor*	+\$4,105

*Must be requested at time of order.
NOTE: Call Customer Service before ordering.

STANDARD ACCESSORIES	
• Electronic Ignition	• Drain Safety Switch
• Rack-type Basket Supports	• Filter Starter Kit
• Basket Hangers	• Casters
	• 8 GPM Pump

GAS LINE TABLE	
# OF FRYERS	GAS LINE
2-3	1"

NOTE: 1-1/2" gas supply line required. Gas inlet size (I.D.) should be no smaller than that provided for connection to the fryers. See service manual and/or plumbing codes for proper pipe sizing.

NOTES

- Basket lifts and split pots not available.
- If ordering for elevation above 2,000 feet, high elevation kit is required. Contact local service agent to order kits.
- Any questions or pricing information other than the above should be referred to Customer Service



Frymaster® FQG100 FILTERQUICK®



TUBE GAS FRYER

- FQ4000 easyTouch® controller makes cooking and filtering simple and intuitive. Fry station management features monitor and help control food and oil quality, oil life, and equipment performance
- Closed-cabinet automatic filtration with rear oil flush puts filtration where it's most convenient to operate, right on the front of the fryer.
- Thermo-tube heat transfer system efficiently transfers energy into the oil, saving energy and extending oil life
- 8GPM pump with 1/3 HP motor
- Optional integrated oil quality sensor monitors the health of the oil and indicates with great precision the true point that oil needs to be discarded
- Innovative safety features offer proprietary advantages over other fryers - prevent simultaneous vat filtrations
- Stainless steel frypots, doors, and sides
- Front oil discharge with 6ft washdown hose



FILTERQUICK

FILTERQUICK 100 FRYER BATTERIES — With filtration, FQ4000 easyTouch controller, stainless steel frypots, doors, and sides.

MODEL	FQ4000 CONTROLLER*	OIL CAPACITY	COOK AREA INCHES	INPUT BTU/HR	SHIPPING WEIGHT
2FQG100T	\$78,680	(2) 100-lbs.	(2) 18 W x 18 L x 5-3/4 D	(2) 105,000	750-lbs.
3FQG100T	\$95,960	(3) 100-lbs.	(3) 18 W x 18 L x 5-3/4 D	(3) 105,000	1,100-lbs.

DESCRIPTION	PRICE
SPECIAL OIL OPTIONS	
Semi-solid / solid shortening*	+\$4,545
Oil Quality Sensor*	+\$4,105

*Must be requested at time of order.
NOTE: Call Customer Service before ordering.

STANDARD ACCESSORIES	
• Electronic Ignition	• Drain Safety Switch
• Rack-type Basket Supports	• Filter Starter Kit
• Basket Hangers	• Casters
	• 8 GPM Pump

GAS LINE TABLE	
# OF FRYERS	GAS LINE
2-3	1"

NOTE: 1-1/2" gas supply line required. Gas inlet size (I.D.) should be no smaller than that provided for connection to the fryers. See service manual and/or plumbing codes for proper pipe sizing.

NOTES

- Basket lifts and split pots not available.
- If elevation is between 2,000-6,000 feet, specify the elevation level. Fryer may not perform at optimum levels above this elevation.
- DO NOT CURB MOUNT.
- Any questions or pricing information other than the above should be referred to Customer Service



Frymaster® FQG120 FILTERQUICK®



TUBE GAS FRYER



- Thermo-Tube frypot design
- Low flue temperature (<650°F/343°C)
- FQ4000 easyTouch® controller makes cooking and filtering simple and intuitive — fry station management features monitor and help control food and oil quality, oil life, and equipment performance
- Electronic ignition
- Optional integrated Oil Quality Sensor monitors the health of the oil and indicates with great precision the true point that oil needs to be discarded
- Closed-cabinet, automatic filtration with rear oil flush puts filtration where it's most convenient to operate, right on the front of the fryer.
- 8 GPM filter pump
- Heat tape wrapped filter lines
- Drain safety switch
- Drain flush, 1-1/2" drain valve, 3" drain
- Basket rack(s)
- Stainless steel frypot, door, and sides
- Basket hanger(s) with flue deflector
- Casters
- Front oil discharge with 6ft washdown hose

FILTERQUICK 120 FRYER BATTERIES — with filtration, FQ4000 easyTouch controller, stainless steel frypots, doors, and sides.

MODEL	FQ4000 CONTROLLER*	OIL CAPACITY	COOK AREA INCHES	INPUT BTU/HR	SHIPPING WEIGHT
2FQG120T	\$89,480	(2) 120-lbs.	(2) 20 W x 20 L x 5-3/4 D	(2) 105,000	750-lbs.
3FQG120T	\$109,320	(3) 120-lbs.	(2) 20 W x 20 L x 5-3/4 D	(3) 105,000	1,100-lbs.

DESCRIPTION	PRICE
SPECIAL OIL OPTIONS	
Semi-solid / solid shortening*	+\$4,545
Oil Quality Sensor*	+\$4,105

*Must be requested at time of order.
NOTE: Call Customer Service before ordering.

STANDARD ACCESSORIES	
• Electronic Ignition	• Drain Safety Switch
• Front discharge with washdown hose	• Filter Starter Kit
• Rack-type Basket Supports	• Casters
• Basket Hangers	• 8 GPM Pump

GAS LINE TABLE	
# OF FRYERS	GAS LINE
2-3	1"

NOTE: 1-1/2" gas supply line required. Gas inlet size (I.D.) should be no smaller than that provided for connection to the fryers. See service manual and/or plumbing codes for proper pipe sizing.

NOTES

- Basket lifts and split pots not available.
- If ordering for elevation above 2,000 feet, high elevation kit is required. Contact local service agent to order kits.
- Any questions or pricing information other than the above should be referred to Customer Service

PART #	DESCRIPTION	SIZE INCHES	APPLICABLE MODELS	PRICE
8030099	Basket, Full Size (Can be used with TANDEM basket lifts)	12-3/8 W x 12-7/8 L x 5-1/4 D	FQG30	\$615
8030435	Basket, Full Size (Cannot be used with basket lifts)	17-1/2 W x 12-7/8 L x 6-1/8 D	FQG60	\$600
8030148	Basket, Full Size	16-3/4 W x 17-1/2 D x 5-3/4 H	FQG100, FQG120	\$640
8030438	Basket, Triplet Size	4-1/4 W x 13-1/4 L x 5-1/2 D	FQG30	\$420
8030357	Basket, Triplet Size	4-1/2 W x 13-1/4 L x 6 D	FQG60	\$420
8030427	Basket, Triplet Size	5-5/8 W x 15-7/8 D x 17-5/8 H	FQG80, FQG100, FQ120	\$445
8030271	Basket, Twin Size	5-7/8 W x 12-5/8 L x 6-5/8 D	FQG30	\$420
8030411	Basket, Twin Size	6 W x 8-3/4 D x 15-1/2 H	FQG80	\$540
8030304	Basket, Twin Size	8-3/4 W x 16-3/4 D x 6 H	FQG100, FQG120	\$420
8030436	Basket, Chicken	17-3/4 W x 12-1/4 L x 11 D	FQG60	\$1,040
8030437	Basket, Dual	8 W x 12-5/8 L x 7 D	FQG60	\$440
2307495	Basket Hanger	31 W x 5 H	FQG30 (2 frypots)	\$450
2307497	Basket Hanger	46-1/2 W x 5 H	FQG30 (3 frypots)	\$665
8237770	Basket Hanger — Over The Flue	20 W x 8-1/2 H	FQG60 (single frypot)	\$295
8237771	Basket Hanger — Over The Flue	39-3/4 W x 8-1/2 H	FQG60 (2 frypots)	\$450
130001403	Basket Hanger	39-3/4 W x 11-1/2 H	FQG80 (2 frypots)	\$560
130001407	Basket Hanger	59-3/4 W x 11-1/2 H	FQG80 (3 frypots)	\$760
8235859	Basket Hanger	20 W x 7 H	FQ100, FQ120	\$295
8030375	Basket Support Rack — Full Pot	11-7/8 W x 13-1/2 D	FQG30	\$305
8030372	Basket Support Rack — Split Pot	5-7/8 W x 13-1/2 D	FQG30	\$265
8030380	Basket Support Rack — Full Pot	13-5/8 W x 18 D	FQG60	\$295
8030149	Basket Support Rack, Fine Mesh	17 W x 17 D	FQG80	\$420
8030528	Basket Support Rack — Full Pot	19 W x 19 D	FQG120	\$560
8102235	Basket Support Rack — Full Pot	17-3/8 W x 17-5/8 D	FQG80, FQG100	\$425
8030429	Brush L-Shaped, Tampico	21 L, 2 Diameter	All Models	\$205
8030278	Brush L-Shaped, Teflon	26-3/4 L, 1 Diameter	All Models	\$255
	Casters – Set of Four Call customer service to specify fryer models		All Models	\$685
8238066	Chicken/Fish Plate — Full Pot	12 W x 13-3/8 D	FQG30	\$760
2208966	Chicken/Fish Plate — Full Pot	18 W x 13-5/8 D	FQG60	\$830
8233947	Chicken/Fish Tray — Full Pot	16-1/2 W x 16-1/2 D x 11 H	FQG80, FQ100, FQ120	\$850
8030388	Clean-Out Rod	27-1/2 L	FQG30	\$265
8030196	Clean-Out Rod	27" L	FQG80, FQG100, FQG120	\$265
8238897	Cover — Stainless Steel — Full Pot	14-5/8 W x 21 D	FQG30	\$595
1081872	Cover — Stainless Steel — Full Pot	21-3/8 W x 19-1/2 D	FQG60	\$595
1061479	Cover — Stainless Steel — Full Pot	23-3/8 W x 19-3/8 D	FQG80	\$700
1062897	Cover — Stainless Steel — Full Pot	18 W x 18-1/2 D	FQG100	\$700
1088956	Cover — Stainless Steel — Full Pot	20 W x 20 D	FQG120	\$595
8233938	Crumb Scoop Cold Zone	1-1/4 W x 6-1/2 D x 22-3/4 L	All Models	\$295
8030430	Ecolab Hi-temp Tools	13-3/8 W x 17-1/3 D	All FQ Models	\$265
8030059	Fish Scoop	8-1/8 W x 8-1/2 D with 17-3/8 L handle	All Models	\$305
2400916	Fish plate, wet battered	13-3/8 W x 17-1/3 D	FQG60	\$835
8030446	Fish Skimmer	6 square with 13-5/8 L insulated handle, no hooks	All Models	\$295
	Foam Deck Basket Banger		All Models	\$480 / FRYPOT
8030293	Gloves, Black Safety		All Models	\$185
8103066	L-Basket Support Rack	17-5/8 W x 17-5/8 D	FQ100	\$495
8103169	Legs – Set of Four – Nickel Call customer service to specify fryer models	6 H		\$685
	Legs – Set of Four – Stainless Steel Call customer service to specify fryer models	6 H		\$685

PART #	DESCRIPTION	SIZE INCHES	APPLICABLE MODELS	PRICE
8100088	Quick Disconnect with 1" Gas Line Systems Only	36 L	FQG30, FQG80, FQG100, FQG120	\$1,320
8100085	Quick Disconnect with 1" Gas Line Systems Only	48 L	FQG30, FQG80, FQG100, FQG120	\$1,410
8061701	Quick Disconnect with 3/4" Gas Line Single Units	36 L	FQG30, FQG60	\$1,065
8061700	Quick Disconnect With 3/4" Gas Line Single Units	48 L	FQG30, FQG60	\$1,160
8239145	Mobile JIB Holder	10-1/2 W x 12-1/4 D x 8-3/8 H	FQ30	\$905
1062631	Sediment Tray — Full Pot	17-3/4 W x 17-1/8 D	FQG80, FQG100, FQG120	\$1,220
8030511	Sediment Tray — Full Pot	11-7/8 W x 13-3/8 L x 6-1/2 D	FQG30	\$1,035
8238224	Splash Shield	19-1/2 D x 11-3/4 H	FQG30	\$595
8237619	Splash Shield	21-3/8 D x 7-7/8 H	FQG60	\$595
130001218	Splash Shield	12 D x 23-1/2 H	FQG80	\$595
8239656	Splash Shield	10 D x 22 H	FQG120	\$595
8235789	Splash Shield	18 D x 14 H	FQ100	\$425
8235810	Top Connecting Strip	1-7/8 W x 20-3/4 D	FQG30	\$370
2102681	Top Connecting Strip	2 W x 21-3/8 D	FQG60	\$370
2105086	Top Connecting Strip	2 W x 23-5/8 D	FQG80	\$370
2600611	Top Connecting Strip	2 W x 18-1/2 D	FQG100	\$370



Super Runner Fryers (Gas and Electric) Outpace the Competition in Performance and Value



SR42 gas fryer shown with optional casters



SR14 electric fryer shown with optional casters



SR62 electric fryer shown with optional casters

- 1. Meet varied production capacity needs.** Model offerings provide 40-75 lb. oil capacity options.
- 2. Can be utilized in operations with gas or electric utilities.** There are four models, three gas and one electric.
- 3. Offer two gas frypot sizes: 14" x 14" and 18" x 18".**
- 4. Have a low warranty failure rate.**
- 5. Have sturdy, long-lasting construction** that includes stainless-steel frypot, door, and backsplash/flue cover.
- 6. Require no electrical hook-up for gas models.**
- 7. Offer an electric model that helps the kitchen stay cool.** Electric elements transfer heat directly to the oil so the kitchen stays cooler.
- 8. Protect against high-heat ignition with reliable high-limit probe.** Gas flow automatically shuts off if temperature exceeds the upper limit.
- 9. Support frying operations with durable accessories** including frypot covers, full size baskets, fine mesh screen, and casters. Triplet baskets are available for the SR62 model's 18" x 18" frypot.

Super Runner Fryers are the front running value fryer of choice.

For more information, contact Customer Service at 1-800-221-4583 or visit www.frymaster.com.

DEAN[®] SR114 SUPER RUNNER

⚡ OPEN POT ELECTRIC FRYER



SHOWN WITH OPTIONAL CASTERS

- Durable temperature probe
- Wide cold zone
- Stainless steel frypot and door with aluminized sides
- Basket hanger
- Twin baskets
- Power switch and indicator light
- 6" (15 cm) steel legs with 1" adjustment standard
- Basket support rack
- Fixed electrical elements

SRE FRYERS — With stainless steel frypot and door with aluminized sides.

MODEL	MILLIVOLT CONTROLLER	OIL CAPACITY	COOK AREA INCHES	INPUT	SHIPPING WEIGHT
SR114E	\$5,490	40-lbs.	13-3/4 W x 13-3/4 L x 5-1/4 D	14 kW	180-lbs.

POWER REQUIREMENTS — BASIC DOMESTIC

MODEL	kW	ELEMENTS / FRYPOT		
		VOLTAGE	3 PHASE ¹	1 PHASE ²
SR114E	14	208V 240V	39 A 34 A	67 A 59 A

¹ 3PH / 3 wire / plus ground wire | ² 1PH / 2 wire / plus ground wire

STANDARD ACCESSORIES

- Legs
- Basket Hanger
- Rack-type Basket Support
- Twin Baskets

NOTES

- Plug is optional accessory on units shipping with a cord.
- Single phase units must be field wired. No plug or cord provided. Check electrical code for proper supply line sizing.
- Any questions or pricing information other than above should be referred to Customer Service.

PART #	DESCRIPTION	SIZE INCHES	APPLICABLE MODELS	PRICE
8030099	Basket, Full Size (Can be used with TANDEM basket lifts)	12-3/8 W x 12-7/8 L x 5-1/4 D	SR114	\$615
8030271	Basket, Twin Size	5-7/8 W x 12-5/8 L x 6-5/8 D	SR114	\$420
8102793	Basket Hanger, Wire	12-1/2 W x 3-1/2 H	SR114	\$295
8030132	Basket Support Rack — Full Pot	12-1/2 W x 13-3/4 D	All Models	\$295
8030429	Brush L-Shaped, Tampico	21 L, 2 Diameter	All Models	\$205
8030278	Brush L-Shaped, Teflon	26-3/4 L, 1 Diameter	All Models	\$255
	Casters, set of 4 (Call Customer Service to specify fryer model)	6" H	All Models	\$685
8030197	Clean-Out Rod	27 L	All Models	\$265
8239414	Cover — Stainless Steel — Full Pot	14-5/8 W x 19-3/8 D	SR114	\$595
8030059	Fish Scoop	8-1/8 W x 8-1/2 D with 17-3/8 L handle	All Models	\$305
8030446	Fish Skimmer	6 square with 13-5/8 L insulated handle, no hooks	All Models	\$295
	Legs, set of 4 adjustable, stainless steel	6" H	All Models	\$685
	Legs, set of 4 adjustable, nickel	6" H	All Models	\$685
2302884	Top Connecting Strip	2-1/4 W x 19-3/4 x 1-5/8 H	All Models	\$370

RE High-Efficiency Electric Fryers

Put every kw to Work at Maximum Efficiency

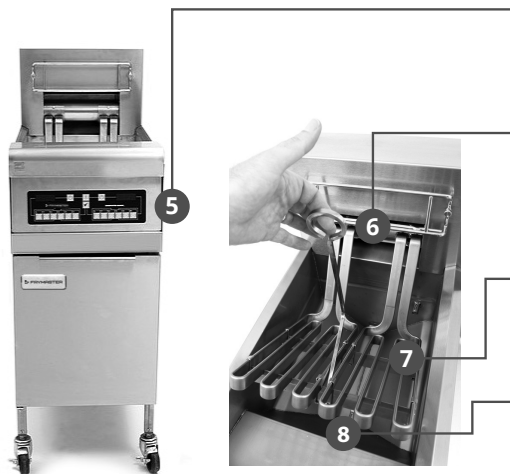
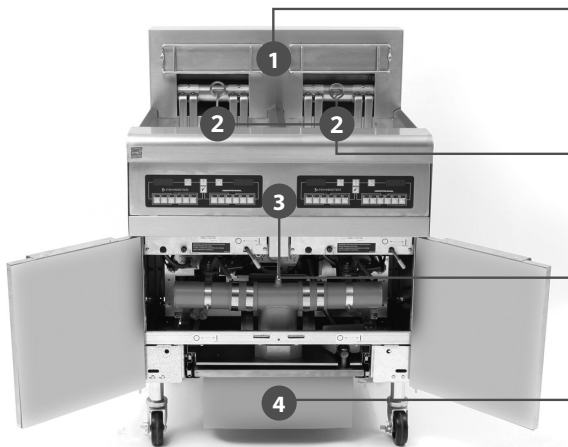

1. **Deliver award winning performance.** The RE fryers have been recognized by the Electric Foodservice Council with a President Choice Award for outstanding contribution to the advancement of electric foodservice equipment.
2. **Help keep the kitchen cool.** With more energy going into the oil, there is less heat going into the ambient air which keeps workers comfortable and reduces demand on HVAC.
3. **Have industry leading energy efficiency** with ASTM ratings greater than 83%. RE fryers are ENERGY STAR® rated and qualify for energy saving rebates.
4. **Can significantly extend oil life, saving thousands of dollars annually on oil costs** with built-in filtration options that make it easy to preserve oil life and ensure great tasting food.
5. **Support a broad range of frying needs** with 14kw, 17kw, and 22kw models, controller options that add features all the way to cook compensation, and basket lift options.
6. **Protect and conserve with safe, self-standing, swing-up, flat-bar heating elements** that allow a highly efficient and uniform transfer of heat into the oil. A sealed rotation housing protects against oil migration.
7. **Produce consistent, high quality food time after time.** RTD temperature probe delivers precise heat response, safeguarding oil life and producing a uniformly-cooked product.
8. **Are easy to clean.** Open frypot design and sturdy self-standing elements allow safe access to every inch of the frypot.

RE Fryers deliver a lifetime of performance.



All E⁴ fryers meet ENERGY STAR guidelines for high efficiency and are part of the Welbilt EnerLogic program.



Frymaster[®] RE14TC

OPEN POT ELECTRIC FRYER

- Open frypot (full or split) design — easy to clean
- Proprietary, self-standing, swing-up, flat-bar, low-watt density, long-life heating elements
- Robust, RTD 1° compensating temperature probe
- CM3.5 controller, standard
- Stainless steel frypot, door, and sides
- Melt cycle and boil out mode
- Deep cold zone with 1-1/4" (3.2 cm) IPS, full-port, ball-type drain valve for full frypots; 1" IPS full-port ball-type drain valve for split frypots
- Triac controls "pulse" the energy required to the electric elements in much smaller increments than traditional on/off electrical contactors or gas controls, resulting in greater reliability and more precise temperature control



HIGH EFFICIENCY

RETFC FRYERS — Without filtration, stainless steel frypot, door and sides.

MODEL	CM3.5 CONTROLLER*	OIL CAPACITY	COOK AREA INCHES	INPUT	SHIPPING WEIGHT
RE14TC	\$17,990	50-lbs.	14 W x 15-1/2 L x 3-3/4 D	14 kW	214-lbs.

*Standard with CM3.5 controller.

14 kW RETFC FRYERS — With filtration, stainless steel frypots, doors, and sides.

MODEL	CM3.5 CONTROLLER*	OIL CAPACITY	COOK AREA INCHES	INPUT	SHIPPING WEIGHT
FPRE214TC	\$51,665	(2) 50-lbs.	(2) 14 W x 15-1/2 L x 3-3/4 D	(2) 14 kW	552-lbs.
FPRE314TC	\$71,235	(3) 50-lbs.	(3) 14 W x 15-1/2 L x 3-3/4 D	(3) 14 kW	705-lbs.
FPRE414TC	\$90,835	(3) 50-lbs.	(3) 14 W x 15-1/2 L x 3-3/4 D	(3) 14 kW	895-lbs.

*Standard with CM3.5 controller. | Filter Price Included. | Price includes casters.

DESCRIPTION	PRICE
SPREADERS	
Spreader Cabinet—15MC	+\$2,405
NOTE: Call Customer Service for availability and placement.	
BASKET LIFTS	
Basket Lifts	+\$4,595/FRYPOT
FRYPOT OPTIONS	
Split Frypot	+\$3,070 /FRYPOT

STANDARD ACCESSORIES	
<ul style="list-style-type: none"> • TRIAC Controls • Automatic Melt Cycle • Boil Out Temperature Control • Legs (non-filter fryers) • Rack-type Basket Support 	<ul style="list-style-type: none"> • Basket Hanger • Twin Baskets • Casters (filter models) • Cord (14 kW)

SPECIAL OIL OPTIONS	
External oil discharge — available on built-in filter batteries of 2 or more frypots or a frypot and spreader. Must specify front or rear connection. Front connection comes with 5 ft. washdown hose.	FRONT +\$2,730 REAR +\$2,090

POWER REQUIREMENTS, PER FRYPOT — BASIC DOMESTIC

MODEL	kW	ELEMENTS / FRYPOT			CONTROLS / FRYPOT	FILTER	BASKET LIFTS / FRYPOTS
		VOLTAGE	3 PHASE ¹	1 PHASE ²			
RE14TC	14	208V	39 A	67 A	1A	5A	2A
RE14-2TC	(2) 7	240V	34 A	58 A	1A	4A	2A

¹3PH / 3 wire / plus ground wire | ²1PH / 2 wire / plus ground wire

OPTIONAL PLUG	
Domestic: NEMA #15-60P	+\$265 /FRYPOT

NOTES

- Standard supplies for all filter systems consist of sample packages of filter powder and paper, one filter brush and one clean-out rod.
- TC models not available in 480V.
- Plug is optional accessory on units shipping with a cord. EXCEPTION: Units shipping to Canada with a cord must have a plug as well.
- All single phase units must be field wired. No plug or cord provided. Check electrical code for proper supply line sizing.
- Controller, filter pump, and basket lifts are powered by element voltages.
- Casters included in basket lift pricing.
- Any questions or pricing information other than the above should be referred to Customer Service



Frymaster[®] RE17TC



OPEN POT ELECTRIC FRYER

- Open frypot (full or split) design -- easy to clean
- Proprietary, self-standing, swing-up, flat-bar, low-watt density, long-life heating elements
- Robust, RTD 1° compensating temperature probe
- CM3.5 controller, standard
- Stainless steel frypot, door, and sides
- Melt cycle and boil out mode
- Deep cold zone with 1-1/4" (3.2 cm) IPS, full-port, ball-type drain valve for full frypots; 1" IPS full-port ball-type drain valve for split frypots
- Triac controls "pulse" the energy required to the electric elements in much smaller increments than traditional on/off electrical contactors or gas controls, Resulting in greater reliability and more precise temperature control



RET C FRYERS — Without filtration, stainless steel frypot, door and sides.

MODEL	CM3.5 CONTROLLER*	OIL CAPACITY	COOK AREA INCHES	INPUT	SHIPPING WEIGHT
RE17TC	\$19,625	50-lbs.	14 W × 15-1/2 L × 3-3/4 D	17 kW	214-lbs.

*Standard with CM3.5 controller.

17 kW RET C FRYERS — With filtration, stainless steel frypots, doors, and sides.

MODEL	CM3.5 CONTROLLER*	OIL CAPACITY	COOK AREA INCHES	INPUT	SHIPPING WEIGHT
FPRE217TC	\$54,935	(2) 50-lbs.	(2) 14 W × 15-1/2 L × 3-3/4 D	(2) 17 kW	552-lbs.
FPRE317TC	\$76,145	(3) 50-lbs.	(3) 14 W × 15-1/2 L × 3-3/4 D	(3) 17 kW	705-lbs.
FPRE417TC	\$97,360	(3) 50-lbs.	(3) 14 W × 15-1/2 L × 3-3/4 D	(3) 17 kW	895-lbs.

NOTE: Filter price included | Price includes casters.

DESCRIPTION	PRICE
SPREADERS	
Spreader Cabinet—15MC	+\$2,405
NOTE: Call Customer Service for availability and placement.	
BASKET LIFTS	
Basket Lifts	+\$4,595 / FRYPOT
FRYPOT OPTIONS	
Split Frypot	+\$3,070 / FRYPOT

STANDARD ACCESSORIES	
• TRIAC Controls	• Basket Hanger
• Automatic Melt Cycle	• Twin Baskets
• Boil Out Temperature Control	• Casters (filter models)
• Legs (non-filter fryers)	• Cord (14 kW)
• Rack-type Basket Support	

SPECIAL OIL OPTIONS	
External oil discharge — available on built-in filter batteries of 2 or more frypots or a frypot and spreader. Must specify front or rear connection. Front connection comes with 5 ft. washdown hose.	FRONT +\$2,730 REAR +\$2,090

POWER REQUIREMENTS, PER FRYPOT — BASIC DOMESTIC

MODEL	kW	ELEMENTS / FRYPOT			CONTROLS / FRYPOT	FILTER	BASKET LIFTS / FRYPOTS
		VOLTAGE	3 PHASE ¹	1 PHASE ²			
RE17TC	17	208V	48 A	82 A	1A	5A	2A
RE17-2TC	(2) 8.5	240V	41 A	71 A	1A	4A	2A

¹ 3PH / 3 wire / plus ground wire | ² 1PH / 2 wire / plus ground wire

OPTIONAL PLUG	PRICE
Domestic: NEMA #15-60P	+\$265 / FRYPOT

NOTES

- Standard supplies for all filter systems consist of sample packages of filter powder and paper, one filter brush, and one clean-out rod.
- TC models not available in 480V.
- Plug is optional accessory on units shipping with a cord. EXCEPTION: Units shipping to Canada with a cord must have a plug as well.
- All single phase units must be field wired. No plug or cord provided. Check electrical code for proper supply line sizing.
- Controller, filter pump, and basket lifts are powered by element voltages.
- Casters included in basket lift pricing.
- Any questions or pricing information other than the above should be referred to Customer Service.



Frymaster RE14

OPEN POT ELECTRIC FRYER

- Open frypot (full or split) design -- easy to clean
- Proprietary, self-standing, swing-up, flat-bar, low-watt density, long-life heating elements
- Robust, RTD 1° compensating temperature probe
- CM3.5 controller, standard
- Stainless steel frypot, door, and sides
- Melt cycle and boil out mode
- Deep cold zone with 1-1/4" (3.2 cm) IPS, full-port, ball-type drain valve for full frypots; 1" IPS full-port ball-type drain valve for split frypots
- Drain safety switch
- Rear oil flush



HIGH EFFICIENCY

RE FRYERS — Without filtration, stainless steel frypot, door and sides.

MODEL	DIGITAL TIMER CONTROLLER	CM3.5 CONTROLLER*	OIL CAPACITY	COOK AREA INCHES	INPUT	SHIPPING WEIGHT
RE14	\$13,205	\$13,205	50-lbs.	14 W x 15-1/2 L x 3-1/2 D	14 kW	190-lbs.

*Standard with CM3.5 controller.

14 kW FRYERS — With filtration, stainless steel frypot(s), door(s) and sides.

MODEL	DIGITAL TIMER CONTROLLER	CM3.5 CONTROLLER*	OIL CAPACITY	COOK AREA INCHES	INPUT	SHIPPING WEIGHT
FPRE114	\$27,480	\$27,480	(1) 50-lbs.	(1) 14 W x 15-1/2 L x 3-1/2 D	(1) 14 kW	277-lbs.
FPRE214	\$42,075	\$42,075	(2) 50-lbs.	(2) 14 W x 15-1/2 L x 3-1/2 D	(2) 14 kW	459-lbs.
FPRE314	\$56,880	\$56,880	(3) 50-lbs.	(3) 14 W x 15-1/2 L x 3-1/2 D	(3) 14 kW	612-lbs.
FPRE414	\$71,665	\$71,665	(4) 50-lbs.	(4) 14 W x 15-1/2 L x 3-1/2 D	(4) 14 kW	811-lbs.

NOTE: Filter price included | Price includes casters.

DESCRIPTION	PRICE
SPREADERS	
Spreader Cabinet—15MC	+\$2,405
NOTE: Call Customer Service for availability and placement.	
BASKET LIFTS	
Basket Lifts	+\$4,595 / FRYPOT
FRYPOT OPTIONS	
Split Frypot	+\$3,250 / FRYPOT

STANDARD ACCESSORIES
<ul style="list-style-type: none"> • Automatic Melt Cycle • Boil Out Temperature Control • Legs (non-filter fryers) • Rack-type Basket Support • Basket Hanger • Twin Baskets • Casters (filter models) • Cord (14 kW)
SPECIAL OIL OPTIONS
External oil discharge — available on built-in filter batteries of 2 or more frypots or a frypot and spreader. Must specify front or rear connection. Front connection comes with 5 ft. washdown hose.
FRONT +\$2,730
REAR +\$2,090

POWER REQUIREMENTS, PER FRYPOT — BASIC DOMESTIC

MODEL	kW	ELEMENTS / FRYPOT			CONTROLS / FRYPOT	FILTER	BASKET LIFTS / FRYPOTS
		VOLTAGE	3 PHASE ¹	1PHASE ²			
RE14	14	208V	39 A	67 A	1A	5A	2A
		240V	34 A	58 A	1A	4A	2A
RE14-2	(2) 7	480V	17 A	N/A	120V 1A	120V 8 A	120V 3 A

¹ 3PH / 3 wire / plus ground wire | ² 1PH / 2 wire / plus ground wire

OPTIONAL PLUG	PRICE
Domestic: NEMA #15-60P	+\$265 / FRYPOT

OPTIONAL POWER	PRICE
480V 3PH	Call customer service for price, per full or dual split frypot.

NOTES

- Standard supplies for all filter systems consist of sample packages of filter powder and paper, one filter brush, and one clean-out rod.
- Plug is optional accessory on units shipping with a cord except 480V 3 phase units — no plug is available. EXCEPTION: Units shipping to Canada with a cord must have a plug as well.
- Single phase units must be field wired. No plug or cord provided. Check electrical code for proper supply line sizing.
- Single phase fryers with built-in filter are available in 240V and 208V only.
- Controller, filter pump, and basket lifts are powered by element voltages except 480V fryers.
- All 480V models are provided with separate 120 volt cord and plug for filter pump, and/or controller, and/or basket lifts.
- Casters included in basket lift pricing.
- Any questions or pricing information other than the above should be referred to Customer Service



Specifications subject to change without notice.



Frymaster® RE17



OPEN POT ELECTRIC FRYER



- Open frypot (full or split) design — easy to clean
- Proprietary, self-standing, swing-up, flat-bar, low-watt density, long-life heating elements
- Robust, RTD 1° compensating temperature probe
- CM3.5 controller, standard
- Stainless steel frypot, door, and sides
- Melt cycle and boil out mode
- Deep cold zone with 1-1/4" (3.2 cm) IPS, full-port, ball-type drain valve for full frypots; 1" IPS full-port ball-type drain valve for split frypots
- Drain safety switch
- Rear oil flush

RE FRYERS — Without filtration, stainless steel frypot, door, and sides.

MODEL	DIGITAL TIMER CONTROLLER	CM3.5 CONTROLLER*	OIL CAPACITY	COOK AREA INCHES	INPUT	SHIPPING WEIGHT
RE17	\$14,730	\$14,730	50-lbs.	14 W x 15-1/2 L x 3-1/2 D	17 kW	190-lbs.

*Standard with CM3.5 controller.

17 kW FRYERS — With filtration, stainless steel frypot(s), door(s) and sides.

MODEL	DIGITAL TIMER CONTROLLER	CM3.5 CONTROLLER*	OIL CAPACITY	COOK AREA INCHES	INPUT	SHIPPING WEIGHT
FPRE117	\$29,015	\$29,015	(1) 50-lbs.	(1) 14 W x 15-1/2 L x 3-1/2 D	(1) 17 kW	277-lbs.
FPRE217	\$45,125	\$45,125	(2) 50-lbs.	(2) 14 W x 15-1/2 L x 3-1/2 D	(2) 17 kW	459-lbs.
FPRE317	\$61,465	\$61,465	(3) 50-lbs.	(3) 14 W x 15-1/2 L x 3-1/2 D	(3) 17 kW	612-lbs.
FPRE417	\$77,785	\$77,785	(4) 50-lbs.	(4) 14 W x 15-1/2 L x 3-1/2 D	(4) 17 kW	811-lbs.

NOTE: Filter price included | Price includes casters.

DESCRIPTION	PRICE
SPREADERS	
Spreader Cabinet—15MC	+\$2,405
NOTE: Call Customer Service for availability and placement.	
BASKET LIFTS	
Basket Lifts	+\$4,595 / FRYPOT
FRYPOT OPTIONS	
Split Frypot	+\$3,250 / FRYPOT

STANDARD ACCESSORIES
<ul style="list-style-type: none"> • Automatic Melt Cycle • Boil Out Temperature Control • Legs (non-filter fryers) • Rack-type Basket Support • Basket Hanger • Twin Baskets • Casters (filter models) • Cord (14 kW)
SPECIAL OIL OPTIONS
External oil discharge — available on built-in filter batteries of 2 or more frypots or a frypot and spreader. Must specify front or rear connection. Front connection comes with 5 ft. washdown hose.
FRONT +\$2,730
REAR +\$2,090

POWER REQUIREMENTS, PER FRYPOT — BASIC DOMESTIC

MODEL	kW	ELEMENTS / FRYPOT			CONTROLS / FRYPOT	FILTER	BASKET LIFTS / FRYPOTS
		VOLTAGE	3 PHASE ¹	1 PHASE ²			
RE17	17	208V 240V	48 A 41 A	82 A 71 A	1A 1A	5A 4A	2A 2A
RE17-2	(2) 8.5	480V	21 A	N/A	480V - 120V 1A	120V 8 A	120V 3 A

¹3PH / 3 wire / plus ground wire | ²1PH / 2 wire / plus ground wire

OPTIONAL PLUG	PRICE
Domestic: NEMA #15-60P	+\$265 / FRYPOT

OPTIONAL POWER	PRICE
480V 3PH	Call customer service for price, per full or dual split frypot.

NOTES

- Standard supplies for all filter systems consist of sample packages of filter powder and paper, one filter brush, and one clean-out rod.
- Plug is optional accessory on units shipping with a cord except 480V 3 phase units — no plug is available. EXCEPTION: Units shipping to Canada with a cord must have a plug as well.
- Single phase units must be field wired. No plug or cord provided. Check electrical code for proper supply line sizing.
- Single phase fryers with built-in filter are available in 240V and 208V only.
- Controller, filter pump, and basket lifts are powered by element voltages except 480V fryers.
- All 480V models are provided with separate 120 volt cord and plug for filter pump, and/or controller, and/or basket lifts.
- No plug or cord is provided on single phase fryers.
- Casters included in basket lift pricing.
- Any questions or pricing information other than the above should be referred to Customer Service



Frymaster[®] RE80 (17 kW)



OPEN POT ELECTRIC FRYER

- Open frypot design — easy to clean
- Proprietary, self-standing, swing-up, flat-bar, low-watt density, long-life heating elements
- Robust, RTD 1° compensating temperature probe
- Digital Timer controller, standard
- Stainless steel frypot, door, and sides
- Melt cycle and boil out mode
- Deep cold zone with 1-1/4" (3.2 cm) IPS, full-port, ball-type drain valve for full frypots; 1" IPS full-port ball-type drain valve for split frypots
- Drain safety switch
- Rear oil flush



HIGH EFFICIENCY

17 kW FRYER — Without filtration, stainless steel frypot, door, and sides.

MODEL	DIGITAL TIMER CONTROLLER*	CM3.5 CONTROLLER	3000 CONTROLLER	OIL CAPACITY	COOK AREA INCHES	INPUT	SHIPPING WEIGHT
RE180	\$16,950	\$20,915	\$21,725	80-lbs.	18 W × 18 L × 4-3/8 D	17 kW	285-lbs.

*Standard with Digital timer.

17 kW FRYERS — With filtration, stainless steel frypot(s), door(s), and sides.

MODEL	DIGITAL TIMER CONTROLLER*	CM3.5 CONTROLLER	3000 CONTROLLER	OIL CAPACITY	COOK AREA INCHES	INPUT	SHIPPING WEIGHT
FPRE180	\$28,915	\$32,900	\$33,700	(1) 80-lbs.	(1) 18 W × 18 L × 4-3/8 D	(1) 17 kW	359-lbs.
FPRE280	\$53,350	\$61,310	\$62,900	(2) 80-lbs.	(2) 18 W × 18 L × 4-3/8 D	(2) 17 kW	617-lbs.
FPRE380	\$72,165	\$84,110	\$86,505	(3) 80-lbs.	(3) 18 W × 18 L × 4-3/8 D	(3) 17 kW	816-lbs.
FPRE480	\$91,015	\$106,920	\$110,125	(4) 80-lbs.	(4) 18 W × 18 L × 4-3/8 D	(4) 17 kW	1,044-lbs.

NOTE: Filter price included.

DESCRIPTION	PRICE
SPREADERS	
Spreader Cabinet—20MC	+\$3,185
NOTE: Call Customer Service for availability and placement.	
BASKET LIFTS	
Basket Lifts	+\$4,595 / FRYPOT
Tandem Basket Lifts	+\$190 / FRYPOT

STANDARD ACCESSORIES	
• Automatic Melt Cycle	• Cords (17 kW)
• Boil Out Temperature Control	• Screen-type Basket Support
• Legs (non-filter fryers)	• 8 GPM Pump
• Casters (filter models)	• Twin Baskets
	• Basket Hangers

SPECIAL OIL OPTIONS	
External oil discharge — available on built-in filter batteries of 2 or more frypots or a frypot and spreader. Must specify front or rear connection. Front connection comes with 5 ft. washdown hose.	FRONT +\$2,730
	REAR +\$2,090

POWER REQUIREMENTS, PER FRYPOT — BASIC DOMESTIC

MODEL	kW	ELEMENTS / FRYPOT		CONTROLS / FRYPOT	FILTER	BASKET LIFTS / FRYPOTS
		VOLTAGE	3 PHASE*			
RE180	17	208V	48 A	1A	5A	2A
		240V	41A	1A	4A	2A
		480V	21A	120V 1A	120V 8 A	120V 3 A

*3PH / 3 wire / plus ground wire

OPTIONAL POWER	OPTIONAL PLUG
480V 3PH Call customer service for price, per full or dual split frypot.	Domestic: NEMA #15-60P +\$265 / FRYPOT

NOTES

- Split pots not available.
- Standard supplies for all filter systems consist of sample packages of filter powder and paper, one filter brush, and one clean-out rod.
- Casters included in basket lift pricing.
- Plug is an optional accessory on units shipping with cord, except 480V 3 phase units — no plug is available. EXCEPTION: Units shipping to Canada with a cord must have a plug as well.
- Controller, filter pump, and basket lifts are powered by element voltages except 480V fryers.
- All 480V models are provided with separate 120 volt cord and plug for filter pump, controller, and/or basket lifts.
- Casters included in basket lift pricing.
- Any questions or pricing information other than the above should be referred to Customer Service



Frymaster[®] RE80 (21kW)



OPEN POT ELECTRIC FRYER



- Open frypot design — easy to clean
- Proprietary, self-standing, swing-up, flat-bar, low-watt density, long-life heating elements
- Robust, RTD 1° compensating temperature probe
- Digital Timer controller, standard
- Stainless steel frypot, door, and sides
- Melt cycle and boil out mode
- Deep cold zone with 1-1/4" (3.2 cm) IPS, full-port, ball-type drain valve for full frypots; 1" IPS full-port ball-type drain valve for split frypots
- Drain safety switch
- Rear oil flush

21 kW FRYER — Without filtration, stainless steel frypot, door and sides.

MODEL	DIGITAL TIMER CONTROLLER*	CM3.5 CONTROLLER	3000 CONTROLLER	OIL CAPACITY	COOK AREA INCHES	INPUT	SHIPPING WEIGHT
RE180	\$18,735	\$22,525	\$23,325	80-lbs.	18 W x 18 L x 4-3/8 D	21 kW	285-lbs.

*Standard with Digital timer controller.

21 kW FRYERS — With filtration, stainless steel frypot(s), door(s), and sides.

MODEL	DIGITAL TIMER CONTROLLER*	CM3.5 CONTROLLER	3000 CONTROLLER	OIL CAPACITY	COOK AREA INCHES	INPUT	SHIPPING WEIGHT
FPRE180	\$30,720	\$34,500	\$35,280	(1) 80-lbs.	(1) 18 W x 18 L x 5 D	(1) 21 kW	359-lbs.
FPRE280	\$56,920	\$64,475	\$66,080	(2) 80-lbs.	(2) 18 W x 18 L x 5 D	(2) 21 kW	617-lbs.
FPRE380	\$77,565	\$88,885	\$91,300	(3) 80-lbs.	(3) 18 W x 18 L x 5 D	(3) 21 kW	816-lbs.
FPRE480	\$98,180	\$113,300	\$116,470	(4) 80-lbs.	(4) 18 W x 18 L x 5 D	(4) 21 kW	1,044-lbs.

NOTE: Filter price included.

DESCRIPTION	PRICE
SPREADERS	
Spreader Cabinet—20MC	+\$3,185
NOTE: Call Customer Service for availability and placement.	
BASKET LIFTS	
Basket Lifts	+\$4,595 / FRYPOT
Tandem Basket Lifts	+\$190 / FRYPOT

STANDARD ACCESSORIES	
• Automatic Melt Cycle	• Cords (17 kW)
• Boil Out Temperature Control	• Screen-type Basket Support
• Legs (non-filter fryers)	• 8 GPM Pump
• Casters (filter models)	• Twin Baskets
	• Basket Hangers

SPECIAL OIL OPTIONS	
External oil discharge — available on built-in filter batteries of 2 or more frypots or a frypot and spreader. Must specify front or rear connection. Front connection comes with 5 ft. washdown hose.	FRONT +\$2,730
	REAR +\$2,090

POWER REQUIREMENTS, PER FRYPOT — BASIC DOMESTIC

MODEL	kW	ELEMENTS / FRYPOT		CONTROLS / FRYPOT	FILTER	BASKET LIFTS / FRYPOT\$
		VOLTAGE	3 PHASE*			
RE180	21	208V 240V 480V	57 A 51 A 26 A	1A 1A 120v 1A	5A 4A 120v 8 A	2A 2A 120v 3 A

*3PH / 3 wire / plus ground wire

OPTIONAL POWER	OPTIONAL PLUG
480V 3PH Call customer service for price, per full or dual split frypot.	Domestic: NEMA #15-60P +\$265 / FRYPOT

NOTES

- Split pots not available.
- Standard supplies for all filter systems consist of sample packages of filter powder and paper, one filter brush, and one clean-out rod.
- Casters included in basket lift pricing.
- All 21 kW units must be field wired. No plug or cord provided. Check electrical code for proper supply line sizing.
- Plug is an optional accessory on units shipping with cord, except 480V 3 phase units — no plug is available. EXCEPTION: Units shipping to Canada with a cord must have a plug as well.
- Controller, filter pump, and basket lifts are powered by element voltages except 480V fryers.
- All 480V models are provided with separate 120 volt cord and plug for filter pump, controller, and/or basket lifts.
- No plug or cord is provided on single phase fryers.
- Any questions or pricing information other than the above should be referred to Customer Service

PART #	DESCRIPTION	SIZE INCHES	APPLICABLE MODELS	PRICE
8030099	Basket, Full Size (Can be used with TANDEM basket lifts)	12-3/8 W x 12-7/8 L x 5-1/4 D	RE14, RE17, RE14TC, RE17TC	\$615
8030148	Basket, Full Size (Can be used with TANDEM basket lifts)	16-3/4 W x 17-1/2 L x 5-3/4 D	RE80	\$640
8030427	Basket, Triplet Size	5-5/8 W x 16 L x 7 D	RE80	\$445
8030357	Basket, Triplet Size	4-1/2 W x 13-1/4 L x 6 D	RE14, RE17	\$420
8030271	Basket, Twin Size	5-7/8 W x 12-5/8 L x 6-5/8 D	RE14, RE17, RE14TC, RE17TC	\$420
8030304	Basket, Twin Size	8-3/4 W x 16-3/4 L x 6 D	RE80	\$420
8030306	Basket, Twin Size	7-5/8 W x 15-7/8 L x 7-3/8 D	RE80 w/BL	\$445
8102793	Basket Hanger, Wire	12-1/2 W x 3-1/2 H	RE14, RE17, RE14TC, RE17TC	\$295
8102794	Basket Hanger	17-3/8 W x 3-1/2 H	RE80	\$295
8030136	Basket Support Screen Type With Handle Full Pot (Not available for split pot)	12-1/2 W x 13-3/4 D	RE14, RE17, RE14TC, RE17TC	\$355
	Casters, Set of Four Call customer service to specify fryer models		All Models	\$685
2208964	Chicken/Fish Plate — Full Pot (Not available for split pot)	13-1/2 W x 14-1/4 D	RE14, RE17, RE14TC, RE17TC	\$760
8233947	Chicken/Fish Tray	16-1/2 W x 16-1/2 L x 11 D	RE80	\$850
1080220	Cover — Stainless Steel — Full Pot	20 x 22-1/4 x 1-1/2 includes handle	RE80	\$710
8239414	Cover — Stainless Steel — Full Pot	14-5/8 W x 19-3/8 D	RE14, RE17, RE14TC, RE17TC	\$595
8233938	Crumb Scoop	1-1/4 W x 6-1/2 D x 22-3/4 L	All Open Pots	\$295
	Foam Deck Basket Banger		RE, RE80	\$480 / FRYPOT
8101205	Legs – Set of Four – Stainless Steel Call customer service to specify fryer models	8-1/2 H	All Models	\$685
8030132	Rack Type Basket Support — Full Pot	12-1/2 W x 13-3/4 D	RE14, RE17, RE14TC, RE17TC	\$295
8030106	Rack Type Basket Support — Split Pot	5-3/4 W x 13-1/2 D	RE14-2, RE17-2, RE14-2TC, RE17-2TC	\$265
8030387	Rack Type Basket Support, Fine Mesh	17-3/8 W x 17-5/8 D	RE80	\$355
8030358	Sediment Tray — Full Pot	10-1/2 W x 11-5/8 L x 4 D	RE14, RE17, RE14TC, RE17TC	\$1,005
8030360L	Sediment Tray — Split Pot Left	4-5/8 W x 13-3/4 L x 4 D	RE14-2, RE17-2, RE14-2TC, RE17-2TC	\$760
8030359R	Sediment Tray — Split Pot Right	4-5/8 W x 13-3/4 L x 4 D	RE14-2, RE17-2, RE14-2TC, RE17-2TC	\$760
8236559	Splash Shield	20 D x 6-1/8 H	RE14, RE17, RE14TC, RE17TC	\$595
8237109	Splash Shield		RE80	\$595
130258103	Splash Shield - Side (with bangers)	24 D x 14 H	RE80	\$595
8235810	Top Connecting Strip	1-7/8 W x 21 D	RE14, RE17, RE14TC, RE17TC	\$370
2305382	Top Connecting Strip	2 W x 23-3/4 D	RE80	\$400

OCF30™

40% Less Oil, 10% Less Energy,
Outstanding Results

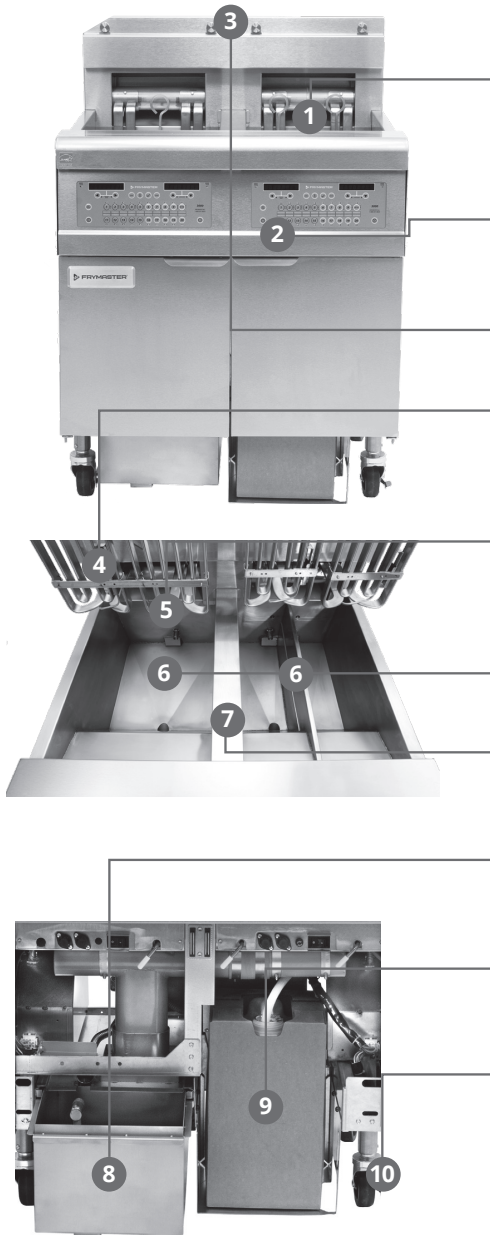

1. **30-lb open frypot design** requires 40% less oil and ensures quick and easy cleaning. Saves money, time and labor.
2. **SMART4U® 3000 controller** helps control food and oil quality, oil life, and equipment performance.
3. **Sturdy basket hangers** are durable and easy to clean.
4. **Safe, self-standing heating elements** ensure industry leading energy efficiency and sealed rotation housing protects against oil migration.
5. **High limit auto reset** requires no tools or operator intervention and an **audible alarm** alerts if a second drain valve is opened.
6. **Robust product line** offers full and split frypots.
7. **Independent frypot construction** allows convenient frypot repairs in the field if needed.
8. **FootPrint PRO® built-in filtration** preserves oil life and ensures consistent, great-tasting food.
9. **Oil Attendant® auto fill option** senses the oil level and adds oil as needed from an in-cabinet supply.
10. **Adjustable leveling casters** accommodate all kitchen designs and floor types.



All OCF30E fryers meet ENERGY STAR® guidelines for high efficiency and are part of the Welbilt EnerLogic™ program.



Frymaster[®] OCF30E



OPEN POT ELECTRIC FRYER

- 30-lb. frypot with open pot design requires 40% less oil to cook as much food as frypots almost twice its size, while using 10% less energy and producing less waste.
- 3000 controller has operation management features that monitor and help control food and oil quality, oil life, and equipment performance. Has 20 programmable cook buttons and auto

adjusts cook time to load size.

- Independent frypot construction of batteries makes it easy to repair or replace a frypot while maintaining continuous operation.
- Durable, self-standing, swing-up, flat-bar heating elements ensure industry-leading energy efficiency that exceeds ENERGY STAR[®] standards and protects against oil migration.



OIL CONSERVING

OCF30 FRYER — With filtration, manual top off, stainless steel frypot, door, and sides.

MODEL	3000 CONTROLLER	OIL CAPACITY	COOK AREA INCHES	INPUT	SHIPPING WEIGHT
FPEL114C	\$24,190	30-lbs.	13 W x 14 L x 3-3/4 D	14 kW	255-lbs.

*Standard with 3000 Controller. Can substitute 3010 for 3000 controller at no additional cost. NOTE: ATO not available on single units.

OCF30 FRYER BATTERIES — With filtration, Automatic Top Off (ATO), stainless steel frypots, doors, and sides

MODEL	3000 CONTROLLER	OIL CAPACITY	COOK AREA INCHES	INPUT	SHIPPING WEIGHT
FPEL214CA	\$40,750	(2) 30-lbs.	(2) 13 W x 14 L x 3-3/4 D	(2) 14 kW	535-lbs.
FPEL314CA	\$55,920	(3) 30-lbs.	(3) 13 W x 14 L x 3-3/4 D	(3) 14 kW	667-lbs.

*Standard with 3000 Controller. Can substitute 3010 for 3000 controller at no additional cost.

DESCRIPTION	PRICE
SPREADERS	
Spreader Cabinet—15MC	+\$2,405
NOTE: Call Customer Service for availability and placement.	
BASKET LIFTS	
Basket Lifts	+\$4,595 / FRYPOT
Tandem basket lifts	+\$190 / FRYPOT
FRYPOT OPTIONS	
Split Frypot	+\$5,160 / FRYPOT

STANDARD ACCESSORIES	
<ul style="list-style-type: none"> • Built-in Filtration • Casters • Rack-type Basket Support • ATO (except FPEL114C) • Basket Hanger 	<ul style="list-style-type: none"> • Twin Baskets • Cords • 8 GPM Pump • Jug in Box (JIB) Holder
SPECIAL OIL OPTIONS	
Bulk Oil (dispose and fresh fill)*	+\$2,865
Semi-solid / solid shortening*	+\$4,545
*Must be requested at time of order. NOTE: Call customer service before ordering.	

POWER REQUIREMENTS, PER FRYPOT — BASIC DOMESTIC

MODEL	kW	ELEMENTS / FRYPOT			CONTROLS / FRYPOT	FILTER	AUTOMATIC TOP OFF (ATO) / FRYPOT	BASKET LIFTS / FRYPOTS
		VOLTAGE	3 PHASE ¹	1PHASE ²				
FPEL14	14	208V	39 A	67 A	1A	5A	1A	2A
		240V	34 A	58 A	1A	4A	1A	2A
		480V	17 A	N/A	120V 1A	120V 8 A	1A	120V 3 A

¹3PH / 3 wire / plus ground wire | ²1PH / 2 wire / plus ground wire

OPTIONAL PLUG	OPTIONAL POWER
Domestic: NEMA #15-60P	480V 3PH
+\$265 / FRYPOT	Call customer service for price, per full or dual split frypot.

NOTES

- Casters included in pricing.
- One cord is provided per frypot.
- Plug is an optional accessory on units shipping with cord, except 480V 3 phase units — no plug is available. EXCEPTION: Units shipping to Canada with a cord must have a plug as well.
- Controller, filter pump, and basket lifts are powered by element voltages except 480V fryers.
- All 480 volt models are provided with separate 120V cord and plug for filter pump, controller, and/or basket lifts.
- No plug or cord is provided on single phase fryers.
- Casters included in basket lift pricing.
- Any questions or pricing information other than the above should be referred to Customer Service



Specifications subject to change without notice.



OPEN POT ELECTRIC FRYER



- 17 kW input per frypot meets high production demands of a varied menu
- Lane controller has programmable cook buttons and features that make it easy to produce consistent greattasting food
- Proprietary, self-standing, swing-up, flat-bar low-watt density long-life heating elements
- High energy efficiency and production capacity
- Robust, RTD 1° compensating temperature probe
- Stainless steel frypot, door, and sides
- Sturdy stainless steel basket hangers

11814E FRYER — Without filtration, stainless steel frypot, door, and sides.

MODEL	DIGITAL TIMER CONTROLLER	CM3.5 CONTROLLER	LANE CONTROLLER	OIL CAPACITY	COOK AREA INCHES	INPUT	SHIPPING WEIGHT
11814E	\$13,260	\$15,230	\$16,810	60-lbs.	18 W x 14 L x 4-1/4 D	17 kW	255-lbs.

*Standard with Lane controller. 3000 and 3010 controller can be substituted for Lane controller at no cost.

11814E FRYERS — With filtration, stainless steel frypot(s), door(s), and sides.

MODEL	DIGITAL TIMER CONTROLLER	CM3.5 CONTROLLER	LANE CONTROLLER	OIL CAPACITY	COOK AREA INCHES	INPUT	SHIPPING WEIGHT
11814EF	\$29,465	\$31,440	\$33,030	(1) 60-lbs.	(1) 18 W x 14 L x 4-1/4 D	(1) 17 kW	390-lbs.
21814EF	\$44,415	\$48,365	\$51,535	(2) 60-lbs.	(2) 18 W x 14 L x 4-1/4 D	(2) 17 kW	585-lbs.
31814EF	\$58,565	\$64,385	\$69,060	(3) 60-lbs.	(3) 18 W x 14 L x 4-1/4 D	(3) 17 kW	815-lbs.

*Standard with Lane controller. 3000 and 3010 controller can be substituted for Lane controller at no cost.

DESCRIPTION	PRICE
SPREADERS	
Spreader Cabinet—20MC	+\$3,185
NOTE: Call Customer Service for availability and placement.	
BASKET LIFTS	
Basket Lifts	+\$4,595 / FRYPOT

STANDARD ACCESSORIES	
• Rack-type Basket Support	• Filter Starter Kit*
• Basket Hangers	• Drain Safety Switch*
• Twin Baskets	• Casters*
• Legs (non-filter models)	• 8 GPM Pump*
*Available on filter models	

POWER REQUIREMENTS, PER FRYPOT — BASIC DOMESTIC

MODEL	kW	ELEMENTS / FRYPOT		CONTROLS / FRYPOT	FILTER
		VOLTAGE	3 PHASE*		
1814E	17	208V	48 A	1A	5A
	17	240V	41 A	1A	4A
	17	480V	21 A	120V 1A	120V 8 A

*3PH / 3 wire / plus ground wire

OPTIONAL PLUG	PRICE
Domestic: NEMA #15-60P	+\$265 / FRYPOT

OPTIONAL POWER	PRICE
480V 3PH	Call customer service for price, per full or dual split frypot.

NOTES

- Split pots not available.
- One cord is provided per frypot.
- Plug is an optional accessory on units shipping with cord, except 480V 3 phase units — no plug is available. EXCEPTION: Units shipping to Canada with a cord must have a plug as well.
- Controller, filter pump, and basket lifts are powered by element voltages except 480V fryers.
- All 480 volt models are provided with separate 120V cord and plug for filter pump, controller, and/or basket lifts.
- No plug or cord is provided on single phase fryers.
- Casters included in basket lift pricing.
- Any questions or pricing information other than the above should be referred to Customer Service

PART #	DESCRIPTION	SIZE INCHES	APPLICABLE MODELS	PRICE
8030099	Basket, Full Size (Can be used with TANDEM basket lifts)	12-3/8 W x 12-7/8 L x 5-1/4 D	OCF30E	\$615
8030435	Basket, Full Size	17-1/2 W x 12-7/8 L x 6-1/8 D	1814E	\$600
8030438	Basket, Triplet Size	4-1/4 W x 13-1/4 L x 5-1/2 D	OCF30E	\$420
8030271	Basket, Twin Size	5-7/8 W x 12-5/8 L x 6-5/8 D	OCF30E, 1814E	\$420
8030437	Basket, Dual	8 W x 12-5/8 L x 7 D	1814E	\$440
8030357	Basket, Triplet	4-1/2 W x 13-1/4 L x 6 D	1814E	\$420
2308165	Basket Hanger	15-3/8 W x 5 H	OCF30E (Single Frypot)	\$295
2307495	Basket Hanger	31 W x 5 H	OCF30E (2 Frypots)	\$450
2307497	Basket Hanger	46-1/2 W x 5 H	OCF30E (3 Frypots)	\$665
2304318	Basket Hanger — Over The Flue	19-7/8 W x 5-1/4 H	11814E (Single Frypot)	\$295
2308464	Basket Hanger — Over The Flue	39-3/4 W x 5-1/4 H	21814E (2 Frypots)	\$450
8030136	Basket Support Screen Type With Handle Full Pot (Not available for split pot)	12-1/2 W x 13-3/4 D	OCF30E	\$355
8030429	Brush L-Shaped, Tampico	21 L, 2 Diameter	All Models	\$205
8030278	Brush L-Shaped, Teflon	26-3/4 L, 1 Diameter	All Models	\$255
	Casters, Set of Four Call customer service to specify fryer models		All Models	\$685
8238065	Chicken/Fish Plate — Full Pot (Not available for split pot)	13-1/2 W x 13-1/8 D	OCF30E	\$760
2208962	Chicken/Fish Plate — Full Pot	17 W x 13-1/2 D	1814E	\$760
8030197	Clean-Out Rod	27 L	All Models	\$265
8238899	Cover — Stainless Steel — Full Pot	14-3/8 W x 19-1/2 D	OCF30E	\$595
8239415	Cover — Stainless Steel — Split Pot	7-1/2 W x 19-3/8 D	OCF30E	\$355
8239402	Cover — Stainless Steel — Full Pot	19 W x 19-3/8 D	1814E	\$595
8233938	Crumb Scoop	1-1/4 W x 6-1/2 D x 22-3/4 L	All Open Pots	\$295
8030059	Fish Scoop	8-1/8 W x 8-1/2 D with 17-3/8 L handle	All Models	\$305
8030446	Fish Skimmer	6 square with 13-5/8 L insulated handle	All Models	\$295
	Foam Deck Basket Banger		OCF30E	\$480 / FRYPOT
8030293	Gloves, Black Safety		All Models	\$185
	Legs — Set of Four — adjustable, stainless steel Call customer service to specify fryer models	6" H	All Models	\$685
	Legs — Set of Four — Stainless Steel Call customer service to specify fryer models	8-1/2 H	11814E	\$685
8030132	Rack Type Basket Support — Full Pot	12-1/2 W x 13-3/4 D	OCF30E	\$295
8030106	Rack Type Basket Support — Split Pot	5-3/4 W x 13-1/2 D	OCF30E	\$265
8030380	Rack Type Basket Support — Full Pot	13-5/8 W x 18 D	1814E	\$295
1086187	Sediment Tray	17-3/4 W x 13-5/8 D	11814E	\$1,220
8238155	Splash Shield	20-5/8 D x 6 H	1814E	\$595
8238224	Splash Shield	19-1/2 D x 11-3/4 H	OCF30E	\$595
8238190	Top Connecting Strip	2-3/4 W x 21 D	11814E	\$370



with FQ4000 easyTouch® Controller
Automatic Filtration and Optional
Oil Quality Sensor

Electric Fryers

Fingertip Filtration Plus:

40% Less Oil, 10% Less Energy, Outstanding Results

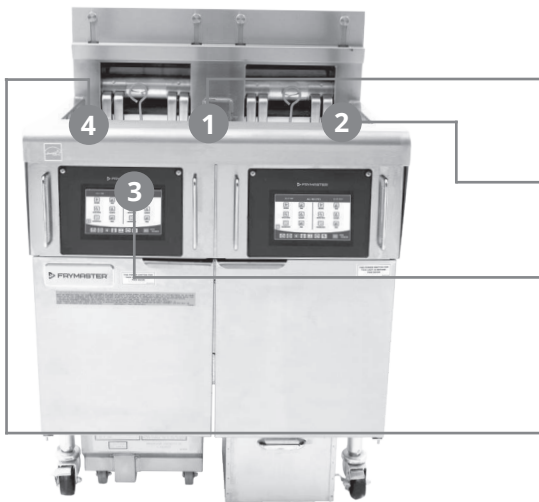

- 30-lb or 60-lb open frypot design** requires 40% less oil and ensures quick and easy cleaning. Saves money, time and labor.
- Independent frypot construction** allows convenient frypot repairs in the field, if needed.
- FQ4000 easyTouch® Controller** has operation management features that monitor and help control food quality, oil life, and equipment performance. Offers configurable and customizable recipe management, and connectivity compatible.
- Safe, self-standing heating elements** ensure industry leading energy efficiency and sealed rotation housing protects against oil migration.

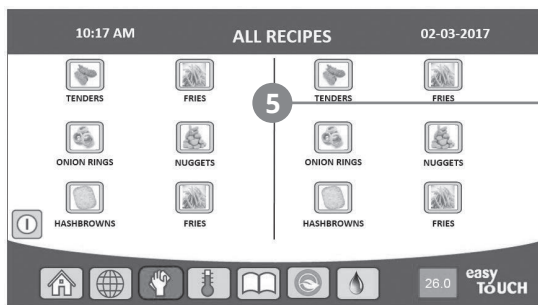

- Fingertip, closed cabinet, fully-automatic filtration** starts with easy touch operating actions.
 - Safe technology ensures only one frypot can drain at a time. Filtration is as easy as pushing a button.
 - The filter pump agitates the oil in the frypot before draining to lift the crumbs from the bottom of the frypot, aiding their removal.
 - The frypot begins heating as soon as a safe level of oil returns to the frypot to speed return to set temperature.
 - The pump is protected by a pressure relief valve for bulk oil systems.



- Optional Oil Quality Sensor (OQS)** monitors the oil's health and advises when to discard. No more guesswork.
- Innovative safety features** offer proprietary advantages over other fryers that prevent simultaneous vat filtrations.
- Automatic Top-Off (ATO) feature** senses the oil level and adds oil as needed from an in-cabinet supply.



FilterQuick fryers exceed ENERGY STAR® guidelines for high efficiency and are part of the Welbilt EnerLogic® program.



Frymaster® FQE30 FILTERQUICK®

OPEN POT ELECTRIC FRYER

- 30-lb. frypot with open pot design requires 40% less oil to cook as much food as frypots almost twice its size, while using 10% less energy and producing less waste
- Frying area 13" W x 14" L x 3-3/4" D (33 x 36 x 9.5 cm) Automatic Top off – automatically replenishes oil from Jug in Box (JIB) conveniently located inside the fryer cabinet
- Closed cabinet, automatic filtration with rear oil flush, puts filtration where it's most convenient to operate, on the front of the fryer
- FQ4000 easyTouch® controller makes cooking and filtering simple and intuitive. Fry station management features monitor and help control food and oil quality, oil life, and equipment performance
- Innovative safety features offer proprietary advantages over other fryers — prevent simultaneous vat filtrations
- Independent frypot construction of batteries makes it easy to repair or replace a frypot while maintaining continuous operation



FILTERQUICK

FILTERQUICK 60 FRYER BATTERIES — With filtration, FQ4000 easyTouch controller, Automatic Top Off (ATO), stainless steel frypot(s), door(s), and sides.

MODEL	FQ4000 CONTROLLER*	OIL CAPACITY	COOK AREA INCHES	INPUT	SHIPPING WEIGHT
2FQE30U	\$53,670	(2) 30-lbs.	(2) 13 W x 14 L x 3-3/4 D	(2) 14 kW	535-lbs.
3FQE30U	\$69,100	(3) 30-lbs.	(3) 13 W x 14 L x 3-3/4 D	(3) 14 kW	667-lbs.
4FQE30U	\$87,055	(4) 30-lbs.	(4) 13 W x 14 L x 3-3/4 D	(4) 14 kW	875-lbs.

*Standard with FilterQuick FQ4000 easyTouch controller. NOTE: Casters included in pricing.

DESCRIPTION	PRICE
SPECIAL OIL OPTIONS	
Semi-solid / solid shortening*	+\$4,545
Front oil discharge (Precludes bulk rear oil discharge)	SPECIFY WHEN ORDERED
Oil Quality Sensor*	+\$4,105

*Must be requested at time of order.
NOTE: Call Customer Service before ordering.

SPREADERS	
Spreader Cabinet—15MC	+\$2,405

NOTE: Call Customer Service for availability and placement.

BASKET LIFTS	
Basket Lifts	+4,595 / FRYPOT

POWER REQUIREMENTS, PER FRYPOT — BASIC DOMESTIC

MODEL	kW	ELEMENTS / FRYPOT			CONTROLS / FRYPOT	FILTER	AUTOMATIC TOP OFF (ATO) / FRYPOT	BASKET LIFTS / FRYPOT
		VOLTAGE	3 PHASE ¹	1 PHASE ²				
FQE30U	14	208V	39 A	67 A	1A	5A	1A	2A
		240V	34 A	58 A	1A	4A	1A	2A
		480V	17 A	N/A	120V 1A	120V 8 A	1A	120V 3 A

¹3PH / 3 wire / plus ground wire | ²1PH / 2 wire / plus ground wire

OPTIONAL PLUG	
Domestic: NEMA #15-60P	+\$265 / FRYPOT

OPTIONAL POWER	
480V 3PH	Call customer service for price, per full or dual split frypot.

NOTES

- Split pots not available.
- One cord is provided per frypot on 3 phase models.
- Plug is an optional accessory on units shipping with cord, except 480V 3 phase units — no plug is available. EXCEPTION: Units shipping to Canada with a cord must have a plug as well.
- Single phase units must be field wired. No cord or plug provided. Check electrical codes for proper supply line sizing.
- Controller, filter pump, and basket lifts are powered by element voltages except 480V fryers.
- All 480 volt models are provided with separate 120 volt cord and plug for filter pump, controller, and/or basket lifts.
- Casters included in basket lift pricing.
- Any questions or pricing information other than the above should be referred to Customer Service



Specifications subject to change without notice.



Frymaster® FQE60 FILTERQUICK®



⚡ OPEN POT ELECTRIC FRYER

- FQ4000 easyTouch® controller makes cooking and filtering simple and intuitive — fry station management features monitor and help control food and oil quality, oil life, and equipment performance
- Proprietary, self-standing, swing-up, flat-bar low-watt density long-life heating elements
- High energy efficiency and production capacity
- Robust, RTD 1° compensating temperature probe
- Stainless steel frypot, door, and sides
- Sturdy stainless steel basket hangers
- Closed cabinet, automatic filtration with rear oil flush puts filtration where it's most convenient to operate, on the front of the fryer
- Innovative safety features offer proprietary advantages over other fryers — prevent simultaneous vat filtrations
- Bulk oil, optional

FILTERQUICK 60 FRYER BATTERIES — With filtration, FQ4000 easyTouch controller, Automatic Top Off (ATO), stainless steel frypot(s), door(s), and sides.

MODEL	FQ4000 CONTROLLER*	OIL CAPACITY	COOK AREA INCHES	INPUT	SHIPPING WEIGHT
1FQE60U	\$49,995	(1) 60-lbs.	(1) 18 W × 14 L × 3-3/4 D	(1) 17 kW	390-lbs.
2FQE60U	\$58,375	(2) 60-lbs.	(2) 18 W × 14 L × 3-3/4 D	(2) 17 kW	585-lbs.
3FQE60U	\$79,900	(3) 60-lbs.	(3) 18 W × 14 L × 3-3/4 D	(3) 17 kW	815-lbs.

*Standard with FilterQuick FQ4000 easyTouch controller. NOTE: Casters included in pricing.

DESCRIPTION	PRICE
SPECIAL OIL OPTIONS	
External oil discharge — available on built-in filter batteries of 2 or more frypots or a frypot and spreader. Must specify front or rear connection. Front connection comes with 5 ft. washdown hose.	FRONT +\$2,730 REAR +\$2,090
Bulk oil (dispose and fresh fill) on batteries with built-in filtration*	+\$4,520
Automatic Top Off (ATO) with side saddle* (Requires additional 3" space)	+\$4,685
Automatic Top Off (ATO) with external 6 ft. hose (no side saddle)*	+\$3,015

*Must be requested at time of order.
NOTE: Call Customer Service before ordering.

BASKET LIFTS	
Basket Lifts	+\$4,595 / FRYPOT

POWER REQUIREMENTS, PER FRYPOT — BASIC DOMESTIC

MODEL	kW	ELEMENTS / FRYPOT		CONTROLS / FRYPOT	FILTER
		VOLTAGE	3 PHASE*		
FQE60U	17	208V	48 A	1A	5A
	17	240V	41A	1A	4A
	17	480V	21A	120V 1A	120V 8 A

*3PH / 3 wire / plus ground wire

OPTIONAL PLUG	
Domestic: NEMA #15-60P	+\$265 / FRYPOT

STANDARD ACCESSORIES	
• Rack-type Basket Support	• Filter Starter Kit
• Basket Hangers	• Drain Safety Switch
• Twin Baskets	• Casters
• 8 GPM Pump	

DESCRIPTION	PRICE
SPREADERS	
Spreader Cabinet—20MC	+\$3,185

NOTE: Call Customer Service for availability and placement.

OPTIONAL POWER	
480V 3PH	Call customer service for price, per full or dual split frypot.

NOTES

- Split pots not available.
- One cord is provided per frypot.
- Plug is an optional accessory on units shipping with cord, except 480V 3 phase units — no plug is available. EXCEPTION: Units shipping to Canada with a cord must have a plug as well.
- Controller, filter pump, and basket lifts are powered by element voltages except 480V fryers.
- All 480 volt models are provided with separate 120V cord and plug for filter pump, controller, and/or basket lifts.
- No plug or cord is provided on single phase fryers.
- Casters included in basket lift pricing.
- Any questions or pricing information other than the above should be referred to Customer Service



Frymaster® FQE80 FILTERQUICK®

OPEN POT ELECTRIC FRYER

- FQ4000 easyTouch® controller makes cooking and filtering simple and intuitive — fry station management features monitor and help control food and oil quality, oil life, and equipment performance
- Proprietary, self-standing, swing-up, flat-bar, low-watt density, long-life heating elements
- High energy efficiency and production capacity
- Robust, RTD 1° compensating temperature probe
- Stainless steel frypot(s), door(s), and sides
- Sturdy stainless steel basket hangers
- Closed cabinet, automatic filtration with rear oil flush puts filtration where it's most convenient to operate, on the front of the fryer
- Innovative safety features offer proprietary advantages over other fryers — prevent simultaneous vat filtrations
- Optional integrated Oil Quality Sensor monitors the health of the oil and indicates with great precision the true point that oil needs to be discarded
- Front oil discharge with 6ft washdown hose



FILTERQUICK

FILTERQUICK 80 FRYER BATTERIES — with filtration, FQ4000 easyTouch controller, stainless steel frypot(s), door(s), and sides.

MODEL	FQ4000 CONTROLLER*	OIL CAPACITY	COOK AREA INCHES	INPUT	SHIPPING WEIGHT
1FQE80U	\$49,105	(2) 80-lbs.	(2) 18 W x 18 L x 4-3/8 D	(2) 17 kW	390-lbs.
2FQE80U	\$67,200	(3) 80-lbs.	(3) 18 W x 18 L x 4-3/8 D	(3) 17 kW	640-lbs.
3FQE80U	\$85,800	(4) 80-lbs.	(4) 18 W x 18 L x 4-3/8 D	(4) 17 kW	814-lbs.

DESCRIPTION	PRICE
SPECIAL OIL OPTIONS	
Semi-solid / solid shortening*	+\$4,545
Oil Quality Sensor*	+\$4,105

*Must be requested at time of order.
NOTE: Call Customer Service before ordering.

STANDARD ACCESSORIES
<ul style="list-style-type: none"> • Rack-type Basket Support • Basket Hangers • Front oil disposal comes with 6ft washdown hose 8 GPM Pump • Filter Starter Kit • Drain Safety Switch • Casters

POWER REQUIREMENTS, PER FRYPOT — BASIC DOMESTIC

MODEL	kW	ELEMENTS / FRYPOT		CONTROLS / FRYPOT	FILTER
		VOLTAGE	3 PHASE*		
FQE80	17	208V	48 A	1 A	5 A
		240V	41 A	1 A	4 A
		480V	21 A	120V 1A	120 V 8 A

*3PH / 3 wire / plus ground wire

OPTIONAL PLUG	PRICE
Domestic: NEMA #15-60P	+\$265 / FRYPOT

OPTIONAL POWER	PRICE
480V 3PH	Call customer service for price, per full or dual split frypot.

NOTES

- Split pots and basket lifts not available.
- One cord is provided per frypot.
- Plug is an optional accessory on units shipping with cord, except 480V 3 phase units — no plug is available. EXCEPTION: Units shipping to Canada with a cord must have a plug as well.
- Controller, filter pump, and basket lifts are powered by element voltages except 480V fryers.
- All 480 volt models are provided with separate 120V cord and plug for filter pump, controller, and/or basket lifts.
- No plug or cord is provided on single phase fryers.
- Any questions or pricing information other than the above should be referred to Customer Service

PART #	DESCRIPTION	SIZE INCHES	APPLICABLE MODELS	PRICE
8030099	Basket, Full Size (Can Be Used With TANDEM Basket Lifts)	12-3/8 W x 12-7/8 L x 5-1/4 D	FQE30	\$615
8030435	Basket, Full Size	17-1/2 W x 12-7/8 L x 6-1/8 D	FQE60	\$600
13000609	Basket, Full Size	17-1/2 W x 16-3/4 L x 6 D	FQE80	\$640
8030438	Basket, Triplet Size	4-1/4 W x 13-1/4 L x 5-1/2 D	FQE30	\$420
8030411	Basket, Twin Size	6 W x 8-3/4 L x 15-1/2 D	FQE80	\$540
8030271	Basket, Twin Size	5-7/8 W x 12-5/8 L x 6-5/8 D	FQE30, FQE60	\$420
8030427	Basket, Triplet size	5-5/8 W x 15-7/8 L x 17-5/8 D	FQE80	\$445
8030437	Basket, Dual	8 W x 12-5/8 L x 7 D	FQE60	\$440
8030357	Basket, Triplet	4-1/2 W x 13-1/4 L x 6 D	FQE60	\$420
2307495	Basket Hanger	31 W x 5 H	FQE30 (2 frypots)	\$450
2307497	Basket Hanger	46-1/2 W x 5 H	FQE30 (3 frypots)	\$665
2600957	Basket Hanger	59-3/4 W x 5-1/5 H	FQE80, FQE60 (2 frypots)	\$790
2304318	Basket Hanger — Over The Flue	19-7/8 W x 5-1/4 H	FQE60, FQE80 (single frypot)	\$295
2308464	Basket Hanger — Over The Flue	39-3/4 W x 5-1/4 H	FQE60, FQE80 (2 frypots)	\$450
8030387	Basket Support Rack, fine mesh	17-3/8 W x 17-5/8 D	FQE80	\$355
8030136	Basket Support Screen Type With Handle Full Pot (Not Available For Split Pot)	12-1/2 W x 13-3/4 D	FQE30	\$355
8030429	Brush L-Shaped, Tampico	21 L, 2 Diameter	All Models	\$205
8030278	Brush L-Shaped, Teflon	26-3/4 L, 1 Diameter	All Models	\$255
	Casters, Set of Four Call customer service to specify fryer models		All Models	\$685
8238065	Chicken/Fish Plate — Full Pot (Not Available For Split Pot)	13-1/2 W x 13-1/8 D	FQE30	\$760
2208962	Chicken/Fish Plate — Full Pot	17 W x 13-1/2 D	FQE60	\$760
8238861	Chicken/Fish Tray — Full Pot	13 W x 13-1/2 D x 11 H	FQE30	\$760
8233947	Chicken/Fish Tray — Full Pot	16-1/2 W x 16-1/2 D x 11 H	FQE80	\$850
8030388	Clean-Out Rod	27-1/2 L	All Models	\$265
8238899	Cover — Stainless Steel — Full Pot	14-3/8 W x 19-1/2 D	FQE30	\$595
8239415	Cover — Stainless Steel — Split Pot	7-1/2 W x 19-3/8 D	FQE30	\$355
8239402	Cover — Stainless Steel — Full Pot	19 W x 19-3/8 D	FQE60	\$595
1080220	Cover — Stainless Steel — Full Pot	20 W x 22-1/4 D (with handle)	FQE80	\$710
8233938	Crumb Scoop	1-1/4 W x 6-1/2 D x 22-3/4 L	All Open Pots	\$295
8030059	Fish Scoop	8-1/8 W x 8-1/2 D with 17-3/8 L handle	All Models	\$305
8030446	Fish Skimmer	6 square with 13-5/8 L insulated handle	All Models	\$295
	Foam Deck Basket Banger		FQE30	\$480 / FRYPOT
8030293	Gloves, Black Safety		All Models	\$185
	Legs — Set of Four — adjustable, nickel Call customer service to specify fryer models	6" H	All Models	\$685
	Legs — Set of Four — adjustable, stainless steel Call customer service to specify fryer models	6" H	All Models	\$685
1086895	Stainless Steel Mobile JIB Container		FQE30	\$905
8030132	Rack Type Basket Support — Full Pot	12-1/2 W x 13-3/4 D	FQE30	\$295
8030106	Rack Type Basket Support — Split Pot	5-3/4 W x 13-1/2 D	FQE30	\$265
8030380	Rack Type Basket Support — Full Pot	13-5/8 W x 18 D	FQE60	\$295
1086187	Sediment Tray	17-3/4 W x 13-5/8 D	FQE60	\$1,220
1062631	Sediment Tray	17-3/4 W x 17-1/8 D	FQE80	\$1,220
8238155	Splash Shield	20-5/8 D x 6 H	FQE60	\$595
8238224	Splash Shield	19-1/2 D x 11-3/4 H	FQE30	\$595
130001221	Splash Shield	11 D x 23-3/5 H	FQE80	\$595
8238190	Top Connecting Strip	2-3/4 W x 21 D	FQE60	\$370
2305382	Top Connecting Strip	2 W x 23-3/4 D	FQE80	\$400

AVAILABLE MODELS	PRODUCT DESCRIPTION	PRICE
OPEN POT FRYERS SPREADER CABINET		
FQ30 (gas and electric), OCF30 (gas and electric), H55, MJ50, MJ40, RE14, RE14TC, RE17, RE17TC	Spreader Cabinet—15MC	\$2,405
1814E, MJCF, RE80, FQE60	Spreader Cabinet—20MC	\$3,185
Add Casters		+\$685
FOOD WARMER AND HOLDING PAN ADDITIONS (MUST BE USED WITH A SPREADER CABINET)		
FWH1	Food Warmer and Holding Pan — Includes heat lamp, cord and plug, and 12" W x 20" L x 2-1/2" D stainless cafeteria style pan and screen.	\$1,810
FWH1A	Food Warmer and Holding Pan — Includes heat lamp, cord and plug, and 13-1/2" W x 17" L x 8" D scoop-type perforated pan.	\$1,980
Holding Pan Only	12" W x 20" L x 2-1/2" D Stainless Cafeteria Style Pan and Screen	\$600
FWH4	Food Warmer and 4" D Cafeteria Style Holding Pan with Scoop Type Grated Screen	\$1,940
TUBE FRYERS SPREADER CABINET, FOOD WARMER AND HOLDING PAN		
PR50, HD50	Spreader Cabinet—15MC	\$1,980
D60G, HD60, 1814G, FQG60	Spreader Cabinet—20MC	\$2,695
Add Casters		+\$685
FOOD WARMER AND HOLDING PAN ADDITIONS (MUST BE USED WITH A SPREADER CABINET)		
FWH1	Food Warmer and Holding Pan — Includes heat lamp, cord and plug, and 12" W x 20" L x 2-1/2" D stainless cafeteria style pan and screen.	\$1,810
FWH1A	Food Warmer and Holding Pan — Includes heat lamp, cord and plug, and 13-1/2" W x 17" L x 8" D scoop-type perforated pan.	\$1,980
Holding Pan Only	12" W x 20" L x 2-1/2" D stainless cafeteria style pan and screen	\$600

NOTES

- Spreader cabinets have a solid flat cover or optional 12" W x 20" D cutout.
- Food Warmers/Holding Pans are optional accessories used with Frymaster/DEAN spreader cabinets.
- Any questions or pricing information other than the above should be referred to Customer Service

MODEL	PRODUCT DESCRIPTION	CAPACITY	SHIPPING WEIGHT	APPLICABLE MODELS	PRICE
FRYMASTER PORTABLE FILTERS					
PF50S	50-lb oil capacity, standard gravity drain	50-lbs.	120-lbs.		\$7,140
PF50R	50-lb oil capacity, reversible pump	50-lbs.	120-lbs.		\$7,140
PF80S	80-lb oil capacity, standard gravity drain	80-lbs.	120-lbs.		\$7,930
PF80R	80-lb oil capacity, reversible pump	80-lbs.	120-lbs.		\$7,930
PF80LPS	80-lb oil capacity, standard gravity drain	80-lbs.	147-lbs.		\$7,930
PF80LPR	80-lb oil capacity, reversible pump	80-lbs.	147-lbs.		\$7,930
PF110S	110-lb oil capacity, standard gravity drain	110-lbs.	125-lbs.		\$8,125
PF110R	110-lb oil capacity, reversible pump	110-lbs.	125-lbs.		\$8,125

NOTE: PF80LPR low profile filters are also recommended for Frymaster and other fryers. R models can be used with any fryer because they have a reversible pump.

NOTES:

- 4 GPM filter pump and 5' return hose included.
- Shipped with Frymaster filter starter kit.
- Available voltage 120V-60 Hz 9 Amp.

PART #	PRODUCT DESCRIPTION	PRICE
FRYMASTER PORTABLE FILTER ACCESSORIES		
8235950	Crumb Tray (for PF50 only)	\$410

MODEL	PRODUCT DESCRIPTION	CAPACITY	SHIPPING WEIGHT	PRICE
FRYMASTER SHORTENING DISPOSAL UNITS				
PSDU50	50-lb oil capacity — fits under all Frymaster and DEAN fryers except DEAN single filtration models	50-lbs.	62-lbs.	\$2,545
PSDU100	100-lb oil capacity — fits under all Frymaster and DEAN fryers including DEAN single filtration models	100-lbs.	80-lbs.	\$3,300

NOTES:

- 9-5/8" drain height with cover open.
- Large 6", high-strength wheels provide easy transporting of oil.

PART #	PRODUCT DESCRIPTION	PRICE
SHORTENING DISPOSAL UNIT ACCESSORIES		
8262173	Hose, 48"	\$670

MODEL	PRODUCT DESCRIPTION	CAPACITY	SIZE INCHES	APPLICABLE MODELS	SHIPPING WEIGHT	PRICE
CLEANING DISPOSAL CADDY						
CDC63	Specifically designed for disposal of boil out solution	8.3 gal	11-1/2 W x 28-1/8 L x 31-7/8 D		30-lbs.	\$2,635
CDC100	Specifically designed for disposal of boil out solution	13.14 gal	16 W x 10 L x 32-1/2 D		120-lbs.	\$3,950

NOTES:

- Any questions or pricing information other than the above should be referred to Customer Service

PART #	ITEM	DESCRIPTION	APPLICABLE MODELS	PRICE
FILTER ACCESSORIES				
8030072	Cone Holder	10" Diameter		\$195
8030197	Clean-out Rod	26" L		\$265
8030059	Fish Scoop	8-1/8" W × 8-1/2" D with 17-3/8" L Handle		\$305
8030042	Filter Cones	10" Diameter — Box of 50		\$220
8030429	Fryer Brush, L-shaped Tampico	21" L, 2" Diameter		\$205
8030278	Fryer Brush, L-shaped Teflon	26-3/4" L, 1" Diameter		\$255
8030002	Filter Powder	Pre-portioned Packs — Box of 80		\$255
8030293	Gloves	Black, Safety		\$185
8233696	Sediment Scoop			\$190
8030446	Skimmer	6" Square with 13-5/8" L Insulated Handle		\$295
8030430	Ecolab Hi-Temp Tools		All FQ Models	\$265

MODEL	PRODUCT DESCRIPTION	PAPER SIZE INCHES	PACKAGING	SHIPPING WEIGHT	APPLICABLE MODELS	PRICE
FILTER MEDIA						
8030003	Filter Magic Filters before 5/90	12-1/2 W × 17-3/4 D	Box of 100	3-lbs.		\$305
8030074	80-lb, MJCF Fryer Filters before 8/90	17-1/2 W × 19-1/4 D	Box of 100	8-lbs.		\$730
8030289	50/60 Series Fryers, UFF Equipped ¹	22 W × 34 D	Box of 100	8-lbs.		\$495
8030170	All Filter Magic, Footprint, and Footprint Pro filters after 5/90	19-1/2 W × 27-1/2 D	Box of 100	4-lbs.		\$305
8030345	50/60/80 Series Fryers, SUFF Equipped ²	17 W × 33-1/4 D	Box of 100	4-lbs.		\$495
8030303	80/100 Series Fryers, UFF Equipped ¹	26 W × 34 D	Box of 100	4-lbs.		\$495
8030317	50 Series Fryers, SUFF Equipped ² (2001 and Older)	8-1/4 W × 25-3/4 D	Box of 100			\$305
8030445	FilterQuick (gas and electric) OCF30 (gas and electric)	16-1/2 W × 25-1/2 D	Box of 100	4-lbs.		\$305
130000811	Masterfil envelope	18-3/8 W × 28-3/4 D	TBD	TBD	FQE80, FQG80	\$305
130000981	Masterfil envelope	23-3/8 W × 31-3/4 D	TBD	TBD	FQG100	\$305

¹UFF-Equipped systems are multi-battered frypots with built-in filtration only. | ²SUFF-Equipped systems are single frypots with built-in filtration only.

MODEL	PRODUCT DESCRIPTION	PAPER SIZE INCHES	PACKAGING	SHIPPING WEIGHT	PRICE
FRYMASTER PORTABLE FILTERS					
8030170	All PF Portable Filters	19-1/2 W × 27-1/2 D	Box of 100	4-lbs.	\$305

NOTES

- Filter paper is specifically designed for each filter system. It is specially woven to allow the free flow of oil, while containing the food particles, sediment and other contaminants drawn by the filter powder. For best results, use only approved filter paper. Use of other paper could void warranty.
- Filter powder is a food-grade filtering agent designed for use with built-in and portable filtering systems. It is specially formulated to remove foreign particles, sediment, and other contaminants from the oil, leaving it freshened, and extending its useful life.
- Any questions or pricing information other than above should be referred to Customer Service



Full Size Basket



Triplet Basket



Twin Baskets



Basket Hanger



Basket Hanger
Over the Flue

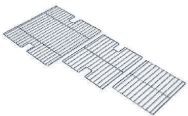

Basket Support Racks

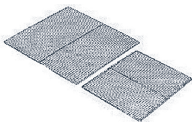

Basket Support Screens

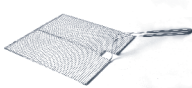

Basket Support Screen
with handle

PART #	DESCRIPTION	SIZE INCHES	APPLICABLE MODELS	PRICE
8030017	Basket, Full Size (Cannot be used with basket lifts)	17-1/2 W x 16-3/4 L x 6 D	MJCF, HD60G, D60G, SR62, FQG80	\$640
8030099	Basket, Full Size (Can be used with TANDEM basket lifts)	12-3/8 W x 12-7/8 L x 5-1/4 D	H55, MJ50, GF40, OCF30, HD50G, PRG50, SR42, SR52	\$615
8030015	Basket, Full Size (Cannot be used with basket lifts)	11-3/4 W x 14 L x 4-5/8 D	MJ40, GF14	\$615
8030435	Basket, Full Size (Cannot be used with basket lifts)	17-1/2 W x 12-7/8 L x 6-1/8 D	1814	\$600
8030148	Basket, Full Size (Can be used with TANDEM basket lifts)	17-1/2 W x 16-3/4 L x 5-7/8 D	LHD65, HD60G, D60G, FQG100, FQG120	\$640
8030357	Basket, Triplet Size	4-1/2 W x 13-1/4 L x 6 D	H55, MJ50, GF40, HD50G, FQ60, PRG50, 1814	\$420
8030023	Basket, Triplet Size	5-3/4 W x 17-1/8 L x 6-1/8 D	MJCF	\$480
8030438	Basket, Triplet Size	4-1/4 W x 13-1/4 L x 5-1/2 D	OCF30	\$420
8030427	Basket, Triplet Size	5-5/8 W x 15-7/8 L x 7-1/4 D	HD60G, LHD65, D60G, SR62, FQG80, FQG100, FQG120	\$445
8030271	Basket, Twin Size	5-7/8 W x 12-5/8 L x 6-5/8 D	H55, MJ50, MJ40, GF40, GF14, OCF30, 1814, HD50G, ESG35T, PRG50, SR42, SR52	\$420
8030411	Basket, Twin Size	6 W x 8-3/4 L x 15-1/2 D	FQG80	\$540
8030024	Basket, Twin Size	8-3/4 W x 16-3/4 L x 6 D	MJCF	\$570
8030304	Basket, Twin Size	8-3/4 W x 16-3/4 L x 6 D	HD60G, LHD65, D60G, SR62, FQG100, FQG120	\$420
8030436	Basket, Chicken	17-3/4 W x 12-1/4 L x 11 D	1814	\$1,040
8030437	Basket, Dual	8 W x 12-5/8 L x 7 D	1814	\$440
8102793	Basket Hanger	12-3/4 W x 3-1/2 L x 1-1/2 D	H55, GF40, GF14, ESG35T, SR42, SR52	\$295
2601808	Basket Hanger, Flue Mounted		MJ50, MJ40	\$255
8102794	Basket Hanger	17-3/8 W x 3-1/2 H	MJCF, RE80, SR62	\$295
2308165	Basket Hanger	15-3/8 W x 5 H	OCF30 (single frypot)	\$295
2307495	Basket Hanger	31 W x 5 H	FQ30 and OCF30 two frypot fryer/ four frypot fryer (2)	\$450
2307497	Basket Hanger	46-1/2 W x 5 H	FQ30 and OCF30 (three frypots)	\$665
130001403	Basket Hanger	39-3/4 W x 11-1/2 H	FQG80 (2 frypots)	\$560
130001407	Basket Hanger	59-3/4 W x 11-1/2 H	FQG80 (3 frypots)	\$760
8237770	Basket Hanger — Over The Flue	20 W x 8-1/2 H	1814 & FQ60 (single frypot)	\$295
8237771	Basket Hanger — Over The Flue	39-3/4 W x 8-1/2 H	1814 & FQ60 (two frypots)	\$450
2101595	Basket Hanger — Over The Flue	15-3/8 W x 6-5/8 H	HD50G (single frypot) Call Customer Service for batteries	\$255
2102737	Basket Hanger — Over The Flue	20 W x 6-5/8 H	HD60G, D60G (singles) Call Customer Service for batteries	\$295
8235859	Basket Hanger With Flue Deflector	20 W x 7 H	LHD65, FQG100, FQG120	\$295
8030132	Basket Support Rack Type — Full Pot	12-1/2 W x 13-3/4 D	H55, MJ50, GF40	\$295
8030032	Basket Support Rack Type — Full Pot	11-1/2 W x 14-5/8 D	MJ40, GF14	\$295
8030137	Basket Support Rack Type — Full Pot	17-1/2 W x 17-1/2 D	MJCF	\$295
8030375	Basket Support Rack Type — Full Pot	11-7/8 W x 13-1/2 D	OCF30	\$305

NOTES

- Any questions or pricing information other than above should be referred to Customer Service

PART #	DESCRIPTION	SIZE INCHES	APPLICABLE MODELS	PRICE
8030372	Basket Support Rack — Split Pot	5-7/8 W x 13-1/2 D	OCF30	\$265
8030133	Basket Support Rack— Split Pot	6 W x 14 D	H55, MJ50	\$265
8030380	Basket Support Rack— Full Pot	13-5/8 W x 18 D	1814, FQ60	\$295
8102235	Basket Support Rack	17-3/8 W x 17-5/8 D	LHD65, HD60G, D60G, SR62, FQG80, FQG100	\$425
8030273	Basket Support Rack	13-1/2 W x 13-1/4 D	HD50G, PRG50, SR42, SR52	\$295
8030442	Basket Support Rack	13-1/2 W x 11-1/4 D	ESG35T	\$295
8030528	Basket Support Rack — Full Pot	19 W x 19 D	FQG120	\$560
8030277	Basket Support Rack, Fine Mesh	13-1/2 W x 13-1/4 D	HD50G, PRG50, SR42, SR52	\$355
8030149	Basket Support Rack, Fine Mesh	17 W x 17 D	LHD65, HD60G, D60G, SR62, FQG80	\$420
8030136	Basket Support Screen With Handle – Full Pot Only	12-1/2 W x 13-3/4 D	H55, MJ50, GF40	\$355
8030037	Basket Support Screen (Full Pot Only)	11-1/2 W x 14-5/8 D	MJ40, GF14	\$345
8030138	Basket Support Screen With Handle — Full Pot Only	17-1/2 W x 18-1/2 D	MJCF	\$355
8103066	L-Basket Support Rack	17-5/8 W x 17-5/8 D	LHD65, FQG100	\$495
8030429	Brush L-Shaped, Tampico	21 L, 2 Diameter	All Models	\$205
8030278	Brush L-Shaped, Teflon	26-3/4 L, 1 Diameter	All Models	\$255
	Casters – Set of Four Call customer service to specify fryer models		All Models	\$685
8230619	Chicken/Fish Plate — Full Pot (Not Available For Split Pot)	12-3/8 W x 14 D	H55, MJ50, GF40	\$770
8236895	Fish/ Chicken Plate — Full Pot, Stainless steel	13-1/2 W x 16-1/2 D x 11 H	PRG50	\$420
8233048	Chicken/Fish Plate — Full Pot	11-3/4 W x 14-3/4 D	MJ40, GF14	\$740
8230368	Chicken/Fish Plate — Full Pot	17-7/8 W x 18 5/8 D	MJCF	\$950
8238066	Chicken/Fish Plate — Full Pot	12 W x 13-3/8 D	FQ30, OCF30	\$760
2208966	Chicken/Fish Plate — Full Pot	18 W x 13-5/8 D	1814	\$830
2208963	Chicken/Fish Tray — Full Pot	13-5/8 W x 13-1/2 D	HD50G	\$760
8233947	Chicken/Fish Tray — Full Pot	16-1/2 x 16-1/2 x 11	HD60G, D60G, FQG80, FQG100, FQG120	\$850
8030197	Clean-Out Rod	27 L	All Models (except FQ)	\$265
8030388	Clean-Out Rod	27-1/2 L	FQ	\$265
8030196	Clean-Out Rod	27 L	FQG80, FQG100, FQG120	\$265
8239416	Cover — Split Pot		H55	\$355
8238898	Cover — Split Pot		OCF30G	\$355
8239413	Cover — Stainless Steel	20-3/8 W x 28 D	MJCF	\$595
8239426	Cover — Stainless Steel — Full Pot	15-1/8 W x 20-1/4 D	H55, MJ50, MJ40, GF40, GF14	\$595
8238897	Cover — Stainless Steel — Full Pot	14-5/8 W x 21 D	FQ, OCF30	\$595
1081872	Cover — Stainless Steel — Full Pot	21-3/8 W x 19-1/2 D	11814	\$595
1088956	Cover — Stainless Steel — Full Pot	20 W x 20 D	FQG120	\$595
1062897	Cover — Stainless Steel — Full Pot	18 W x 18-1/2 D	FQG100	\$595



L-Shaped Brush Tampico



L-shaped Brush Teflon

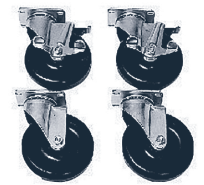

Casters

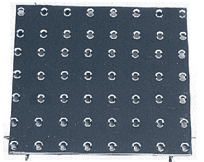

Chicken/Fish Plate



Clean-out Rod

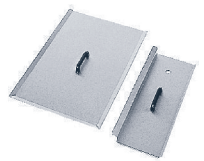

Covers



Crumb Scoop

NOTES

- Any questions or pricing information other than above should be referred to Customer Service



Fish Scoop, Left
Fish Skimmer, Right



Flue Deflector

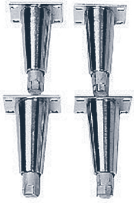

Legs



Quick Disconnect



Sediment Tray
Full Pot



Sediment Tray
MJCF Gas Fryer

PART #	DESCRIPTION	SIZE INCHES	APPLICABLE MODELS	PRICE
1061637	Cover — Stainless Steel – Full Pot	13-1/2 W × 21-3/8 D	HD50G, ESG35T, PRG50, SR42, SR52	\$595
1061479	Cover — Stainless Steel without Basket Lifts	23-3/8 W × 19-3/4 D	HD60G, D60G, SR62, FQG80	\$700
1062734	Cover — Stainless Steel w Basket lifts	14-1/4 W × 20-1/2 D	HD50G, PRG50	\$555
1062773	Cover — Stainless Steel w Basket lifts	18 W × 22-5/8 D	HD60G, D60G	\$700
8233938	Crumb Scoop Cold Zone	1-1/4 W × 6-1/2 D × 22-3/4 L	All Models	\$295
8030430	Ecolab Hi-Temp Tools		All FQ Models	\$265
8030059	Fish Scoop	8-1/8 W × 8-1/2 D with 17-3/8 L handle	All Models	\$305
2400916	Fish plate, wet battered		1814G	\$835
8030446	Fish Skimmer	6 square with 13-5/8 L insulated handle, no hooks	All Models	\$295
9103557	Flue Deflector	12-1/2 W × 6-7/8 H	H55, MJ50, MJ40 GF40, GF14	\$315
9103185	Flue Deflector	14-1/2 W × 8 H	MJCF	\$315
8235801	Flue Deflector	20 W × 9-1/2 H	LHD65	\$315
	Foam Deck Basket Banger		1814, OCF, FQ, H55, HD50G, HD60G, MJ50, FQG80, FQG100, FQG120	\$480 / FRYPOT
8030293	Gloves, Black Safety		All Models	\$185
2003649	Flue deflector	18-3/8 W × 3 H	D60G	\$345
2003651	Flue deflector	15-3/8 W × 3 H	PRG50	\$255
8103169	Legs – Set of Four – Nickel Call customer service to specify fryer models	6 H	All Models	\$685
8101205	Legs – Set of Four – Stainless Steel Call customer service to specify fryer models	6 H	All Models	\$685
	Legs – Set of Four – Stainless Steel Call customer service to specify fryer models	8-1/2 H	H55, 1814	\$685
8239145	Mobile JIB Holder	10-1/2 W × 12-1/4 D × 8-3/8 H	OCF30, FQ30	\$905
1086895	Stainless Steel Mobile JIB container		FQG30	\$905
8100088	Quick Disconnect with 1" Gas Line Systems Only	36 L	H55, MJ50, MJ40, MJCF, 1814, OCF30, LHD65, FQG100, FQG120	\$1,320
8100085	Quick Disconnect with 1" Gas Line Systems Only	48 L	H55, MJ50, MJ40, MJCF, 1814, OCF30, LHD65, FQG100, FQG120	\$1,410
8061701	Quick Disconnect with 3/4" Gas Line Single Units	36 L	H55, MJ50, MJ40 GF40, GF14, 1814, OCF30G, LHD65	\$1,065
8061700	Quick Disconnect With 3/4" Gas Line Single Units	48 L	H55, MJ50, MJ40 GF40, GF14, 1814, OCF30G, LHD65	\$1,160
8030103	Sediment Tray — Full Pot	12-1/2 W × 14 L × 6-1/2 D	H55, MJ50, GF40	\$1,005
8030188	Sediment Tray — Full Pot	11-1/4 W × 14-1/2 L × 4-1/8 D	MJ40, GF14	\$830
8030187	Sediment Tray — Full Pot	17-1/2 W × 18-1/2 L × 4-3/8 D	MJCF	\$1,000

NOTES

- Any questions or pricing information other than above should be referred to Customer Service

PART #	DESCRIPTION	SIZE INCHES	APPLICABLE MODELS	PRICE
8030511	Sediment Tray — Full Pot	11-7/8 W × 13-3/8 L × 6-1/2 D	OCF30	\$1,035
8030107L	Sediment Tray — Split Pot Left	5-7/8 W × 14 L × 6-1/2 D	H55-2	\$760
8030108R	Sediment Tray — Split Pot Right	5-7/8 W × 14 L × 6-1/2 D	H55-2	\$760
1064136	Sediment Tray	13-1/2 W × 13-3/4 D	HD50G, PRG50	\$1,035
1062631	Sediment Tray	17-3/4 W × 17-1/8 D	HD60G, D60G, SR62, FQG80, FQG100, FQG120	\$1,220
1086187	Sediment Tray	17-3/4 W × 13-5/8 D	1814E, FQ60	\$1,220
8236559	Splash Shield	20 D × 6-1/4 H	H55, MJ50, MJ40	\$595
8235978	Splash Shield	30-3/8 D × 13-1/8 H	MJCF	\$595
8237619	Splash Shield	21-3/8 D × 7-7/8 H	11814, FQ60	\$595
130001218	Splash Shield	12 D × 23-1/2 H	FQG80	\$595
8238224	Splash Shield	19-1/2 D × 11-3/4 H	FQ30, OCF30	\$595
8233225	Splash Shield	21-1/2 D × 13 H	HD50G, PRG50, SR142	\$355
8235744	Splash Shield	23 1/2 D × 14 H	HD60G, D60G	\$355
8235789	Splash Shield	18 D × 14 H	LHD65, FQG100	\$425
8239656	Splash Shield	10 D × 22 H	FQG120	\$595
2109291	Top Connecting Strip	2-1/4 W × 20-1/2 D	H55, MJ50, MJ40	\$370
9102662	Top Connecting Strip	2-1/8 W × 28-1/8 D	MJCF	\$425
2102681	Top Connecting Strip	2 W × 21-3/8 D	1814G, HD50, PRG50, SR42, SR52	\$370
2105086	Top Connecting Strip	2 W × 23-5/8 D	HD60G, D60G, LHD65, FQG80	\$370
8235810	Top Connecting Strip	1-7/8 W × 20-3/4 D	OCF30G	\$370
9102285	Top Connecting Strip	2-1/8 W × 20-5/8 D	GF14, GF40	\$370
2600611	Top Connecting Strip	2 W × 18-1/2 D	FQG100	\$370



Splash Shield



Top Connecting Strip

NOTES

- Any questions or pricing information other than above should be referred to Customer Service



Full Size Basket



Triplet Basket



Twin Baskets



Basket Hanger

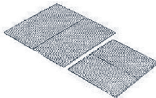

Basket Support Screens

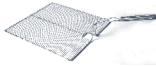

Basket Support Screen with handle



L-Shaped Brush Tampico



L-shaped Brush Teflon



Casters

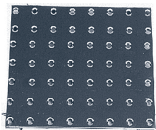

Chicken/Fish Plate

PART #	DESCRIPTION	SIZE INCHES	APPLICABLE MODELS	PRICE
8030099	Basket, Full Size (Can be used with TANDEM basket lifts)	12-3/8 W x 12-7/8 L x 5-1/4 D	RE14, RE17, RE14TC, RE17TC, OCF30, SR14E	\$615
8030148	Basket, Full Size (Can be used with TANDEM basket lifts)	16-3/4 W x 17-1/2 L x 5-3/4 D	RE80	\$640
13000609	Basket, Full Size	17-1/2 W x 16-3/4 L x 6 D	FQE80	\$640
8030435	Basket, Full Size	17-1/2 W x 12-7/8 L x 6-1/8 D	1814	\$600
8030427	Basket, Triplet Size	5-5/8 W x 16 L x 7 D	RE80, FQE80	\$445
8030357	Basket, Triplet Size	4-1/2 W x 13-1/4 L x 6 D	RE14, RE17, 1814	\$420
8030438	Basket, Triplet Size	4-1/4 W x 13-1/4 L x 5-1/2 D	OCF30	\$420
8030271	Basket, Twin Size	5-7/8 W x 12-5/8 L x 6-5/8 D	RE14, RE17, RE14TC, RE17TC, OCF30, SR14E, 1814E	\$420
8030304	Basket, Twin Size	8-3/4 W x 16-3/4 L x 6 D	RE80	\$420
8030411	Basket, Twin Size	6 W x 8-3/4 L x 15-1/2 D	FQE80	\$540
8030306	Basket, Twin Size	7-5/8 W x 15-7/8 L x 7-3/8 D	RE80 w/BL	\$445
8030437	Basket, Dual	8 W x 12-5/8 L x 7 D	1814	\$440
8102793	Basket Hanger, Wire	12-1/2 W x 3-1/2 H	RE14, RE17, RE14TC, RE17TC, SR14E	\$295
2308165	Basket Hanger	15-3/8 W x 5 H	OCF30, FQ30 (single frypot)	\$295
2307495	Basket Hanger	31 W x 5 H	FQ30 and OCF30 (2 frypots / 4 frypots [2])	\$450
2307497	Basket Hanger	46-1/2 W x 5 H	FQ30 and OCF30 (3 frypots)	\$665
2600957	Basket Hanger	59-3/4 W x 5-1/5 H	FQE60, FQE80 (3 frypots)	\$790
8102794	Basket Hanger	17-3/8 W x 3-1/2 H	RE80	\$295
2304318	Basket Hanger — Over The Flue	19-7/8 W x 5-1/4 H	11814E, FQE60, FQE80 (single frypot)	\$295
2308464	Basket Hanger — Over The Flue	39-3/4 W x 5-1/4 H	1814E, FQE60, FQE80 (2 frypots)	\$450
8030136	Basket Support Screen Type With Handle Full Pot (Not Available For Split Pot)	12-1/2 W x 13-3/4 D	RE14, RE17, RE14TC, RE17TC, OCF30, FQ30	\$355
8030429	Brush L-Shaped, Tampico	21 L, 2 Diameter	All Models	\$205
8030278	Brush L-Shaped, Teflon	26-3/4 L, 1 Diameter	All Models	\$255
	Casters, Set of Four Call customer service to specify fryer models		All Models	\$685
8238065	Chicken/Fish Plate — Full Pot (Not available for split pot)	13-1/2 W x 13-1/8 D	FQ30, OCF30	\$760
2208964	Chicken/Fish Plate — Full Pot (Not available for split pot)	13-5/8 W x 14-1/4 D	RE14, RE17, RE14TC, RE17TC	\$760
2208962	Chicken/Fish Plate — Full Pot	17 W x 13-1/2 D	1814E	\$760
8238861	Chicken/Fish Tray — Full Pot	13 W x 13-1/2 D x 11 H	FQ30	\$760
8233947	Chicken/Fish Tray	16-1/2 W x 16-1/2 L x 11 D	RE80, FQE80	\$850
8030197	Clean-Out Rod	27 L	All Models (except FQ)	\$265
8030388	Clean-Out Rod	27-1/2 L	FQ	\$265
8030196	Clean-Out Rod		FE60, FE80	\$265

NOTES

- Any questions or pricing information other than above should be referred to Customer Service

PART #	DESCRIPTION	SIZE INCHES	APPLICABLE MODELS	PRICE
1080220	Cover — Stainless Steel — Full Pot	20 W × 22-1/4 L × 1-1/2 D includes handle	RE80	\$710
8239414	Cover — Stainless Steel — Full Pot	14-5/8 W × 19-3/8 D	RE14, RE17, RE14TC, RE17TC, SR14E, FQE80	\$595
8238899	Cover — Stainless Steel — Full Pot	14-3/8 W × 19-1/2 D	OCF30, FQ30	\$595
8239415	Cover — Stainless Steel — Split Pot	7-1/2 W × 19-3/8 D	OCF30, RE14, RE17, RE14TC, RE17TC, FQ30	\$355
8239402	Cover — Stainless Steel — Full Pot	19 W × 19-3/8 D	1814E, FQ60	\$595
8233938	Crumb Scoop	1-1/4 W × 6-1/2 D × 22-3/4 L	All Open Pots	\$295
8238065	Fish Plate	13 W × 13-1/2 L × 4-1/2 D	FQ30, OCF	\$760
8030059	Fish Scoop	8-1/8 W × 8-1/2 D with 17-3/8 L handle	All Models	\$305
8030446	Fish Skimmer	6 square with 13-5/8 L insulated handle	All Models	\$295
	Foam Deck Basket Banger		OCF, RE, RE80, FQ models	\$480 / FRYPOT
8030293	Gloves, Black Safety		All Models	\$185
	Legs – Set of Four – Stainless Steel Call customer service to specify fryer models	8-1/2 H	RE14, RE17, RE14TC, RE17TC, RE80, 11814E	\$685
	Legs – Set of Four – Nickel Call Customer Service to specify fryer models	6" H	All Models	\$685
1086895	Stainless Steel Mobile JIB Container		FQE30	\$905
8030132	Rack Type Basket Support — Full Pot	12-1/2 W × 13-3/4 D	RE14, RE17, RE14TC, RE17TC, OCF30 Fryers	\$295
8030106	Rack Type Basket Support — Split Pot	5-3/4 W × 13-1/2 D	RE14-2, RE17-2, RE14-2TC, RE17-2TC, OCF Fryers	\$265
8030380	Rack Type Basket Support — Full Pot	13-5/8 W × 18 D	1814E, FQ60	\$295
8030387	Rack Type Basket Support, Fine Mesh	17-3/8 W × 17-5/8 D	RE80, FQ80	\$355
8030358	Sediment Tray — Full Pot	10-1/2 W × 11-5/8 L × 4 D	RE14, RE17, RE14TC, RE17TC	\$1,005
8030360L	Sediment Tray — Split Pot Left	4-5/8 W × 13-3/4 L × 4 D	RE14-2, RE17-2, RE14-2TC, RE17-2TC	\$760
8030359R	Sediment Tray — Split Pot Right	4-5/8 W × 13-3/4 L × 4 D	RE14-2, RE17-2, RE14-2TC, RE17-2TC	\$760
1086187	Sediment Tray	17-3/4 W × 13-5/8 D	11814E, FQ60	\$1,220
1062631	Sediment Tray	17-3/4 W × 17-1/8 D	FQE80	\$1,220
8236559	Splash Shield	20 D × 6-1/8 H	RE14, RE17, RE14TC, RE17TC	\$595
8238155	Splash Shield	20-5/8 D × 6 H	1814E, FQ60	\$595
8238224	Splash Shield	19-1/2 D × 11-3/4 H	FQ30, OCF30	\$595
8237109	Splash Shield		RE80	\$595
130001221	Splash Shield	11 D × 23-3/5 H	FQE80	\$595
8235810	Top Connecting Strip	1-7/8 W × 21 D	RE14, RE17, RE14TC, RE17TC	\$370
2305382	Top Connecting Strip	2 W × 23-3/4 D	RE80, FQE80	\$400
8238190	Top Connecting Strip	2-3/4 W × 21 D	11814E, FQ60	\$370
2302884	Top Connecting Strip	2-14 W × 19-3/4 D × 1-5/8 H	SR114	\$370



Clean-out Rod



Covers



Fish Scoop, Left
Fish Skimmer, Right

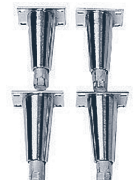

Legs

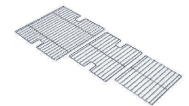

Basket Support Racks



Sediment Tray
Full Pot



Splash Shield



Top Connecting Strip

NOTES

- Any questions or pricing information other than above should be referred to Customer Service

MODEL NUMBER	FRYER CATEGORY	ENERGY REQUIREMENTS	OIL CAPACITY	COOKING AREA INCHES (CM) W x D x H	WIDTH INCHES (CM)	DEPTH INCHES (CM)	HEIGHT INCHES (CM)	PRODUCTION PER HR. (FULL FRYPOT)	APPROX. CUBIC FEET SHIP WT.
1814	Oil Conserving	119,000 Btu/hr. (34.9 kW)	63-lbs. (31 liters)	18 x 14 x 3-3/4 (45.7 x 35.6 x 9.5)	20 (50.8)	33-1/8 (84.1)	47-3/4 (121.3)	84-lbs. Fries/hr.	40 255-lbs. (116 kg)
FQG30U	FilterQuick	70,000 Btu/hr. (20.5 kW)	30-lbs. (15 liters)	13 x 14 x 3-3/4 (33 x 36 x 9.5)	31-1/4 (79.4)	29-7/8 (76)	46-1/2 (118)	67-lbs. Fries/hr.	52 575-lbs. (261 kg)
FQG60	FilterQuick	119,000 BTU/hr. (34.9 kW/hr)	63-lbs. (31 liters)	18 x 14 x 3-3/4 (45.7 x 35.6 x 9.5)	20 (50.8)	33-1/8 (84.1)	47-3/4 (121.3)	87-lbs. Fries/hr.	39.6 390-lbs.(177 kg)
FQG80 ¹	FilterQuick	125,000 BTU/hr.	80-lb. (40 liter)	18 x 18 x 4-3/4 (46 x 46 x 10.8)	40-3/8 (102.6)	36-7/8 (93.6)	43-3/4 (111.1)	107 lbs. fries 80 lbs. bone-in chicken	56 510 lbs. (231 kg)
FQG100 ¹	FilterQuick	105,000 BTU/hr.	100-lb. (50 liter)	18 x 18 x 5-3/4 (46 x 46 x 15)	40 (101.6)	36-1/4 (92.1)	43 (109.2)	79 lbs. fries 105 pcs bone-in chicken	72.9 750 lbs. (340 kg)
FQG120 ¹	FilterQuick	105,000 BTU/hr.	120-lb. (54 liter)	20 x 20 x 5-3/4 (50.8 x 50.8 x 15)	43.8 (111.3)	40 (101.6)	43 (109.2)	128 pcs bone-in chicken	72.9 750 lbs. (340 kg)
OCF30 (FPGL#30)	Oil Conserving	70,000 Btu/hr. (20.5 kW)	30-lbs. (15 liters)	13 x 14 x 3-3/4 (33 x 36 x 9.5)	15-5/8 (39.7)	35-5/8 (90.5)	45-3/8 (115.3)	67-lbs. Fries/hr.	20 265-lbs. (120 kg)
ESG35T	High Efficiency	70,000 Btu/hr. (20.5 kW)	35-lbs. (17 liters)	14 x 13-3/4 x 4-1/5 (35 x 34.9 x 10.7)	15-1/2 (39.4)	29-1/8 (74)	44 (111.8)	58-lbs. Fries/hr.	22 165-lbs. (75 kg)
HD50	High Efficiency	100,000 Btu/hr. (29.3 kW)	50-lbs. (25 liters)	14 x 14 x 3-1/2 (35 x 35 x 8.9)	15-1/2 (39.4)	31-1/4 (79.4)	45 (114.3)	72-lbs. Fries/hr.	22 180-lbs. (82 kg)
HD60	High Performance	125,000 Btu/hr. (36.6 kW)	75-lbs. (40 liters)	18 x 18 x 3-3/4 (46 x 46 x 9.5)	20 (50.8)	36-3/4 (93.4)	45 (114.3)	107-lbs. Fries/hr.	32 255-lbs. (116 kg)
LHD65	High Efficiency	105,000 Btu/hr. (30.8 kW)	100-lbs. (50 liters)	18 x 18 x 5-3/4 (46 x 46 x 14.6)	20 (50.8)	36-1/4 (92.1)	43 (109.2)	128 pcs. Bone-in Chicken/hr.	72.9 260-lbs. (118 kg)
H55 H55-2	High Efficiency	80,000 Btu/hr. (23.4 kW)	50-lbs. (25 liters)	14 x 15 x 4-1/2 (35.6 x 38.1 x 11.4)	15-5/8 (39.7)	29-5/8 (75.3)	45-5/8 (115.8)	68-lbs. Fries/hr.	22 202-lbs. (92 kg)
	High Efficiency	40,000 Btu/hr. (11.7 kW) per split	25-lbs. (12 liters)	6-1/2 x 15 x 4-3/4 (16.5 x 38.1 x 12.1)					
MJ50	High Performance	122,000 Btu/hr. (35.8 kW)	50-lbs. (25 liters)	14 x 15 x 5 (35.6 x 38.1 x 12.7)	16 (40.6)	31-5/8 (80.3)	46-3/8 (118)	69-lbs. Fries/hr.	20 202-lbs. (92 kg)
MJ40	High Performance	110,000 Btu/hr. (32.2 kW)	40-lbs. (20 liters)	12 x 15 x 4-1/4 (30.5 x 38.1 x 10.8)	16 (40.6)	31-5/8 (80.3)	41-3/8 (105)	57-lbs. Fries/hr.	20 185-lbs. (84 kg)
MJCF	High Performance	150,000 Btu/hr. (44 kW)	80-lbs. (40 liters)	18 x 19 x 4-1/2 (45.7 x 48.3 x 11.4)	20-3/4 (52.7)	39-7/8 (101.2)	46-3/8 (117.7)	80-lbs. Chicken/hr. 100 lbs. Fish/hr.	32 297-lbs. (135 kg)
GF40	Value	122,000 Btu/hr. (35.8 kW)	50-lbs. (25 liters)	14 x 15 x 5 (35.6 x 38.1 x 12.7)	15-5/8 (39.7)	30-7/8 (78.4)	46-1/8 (117.1)	69-lbs. Fries/hr.	21 176-lbs. (80 kg)
GF14	Value	100,000 Btu/hr. (29.3 kW)	40-lbs. (20 liters)	12 x 15 x 4 (30.5 x 38.1 x 10.2)	15-5/8 (39.7)	30-7/8 (78.4)	41-1/8 (104.4)	57-lbs. Fries/hr.	19 152-lbs. (69 kg)
PRG50T	Value Performance	120,000 Btu/hr. (35.2kW)	50-lbs. (25 liters)	14 x 14 x 3-1/2 (35 x 35 x 8.9)	5-1/2 (39.4)	31-1/4 (79.4)	46-1/8 (117)	63-lbs. Fries/hr.	22 180-lbs. (22 kg)
SR42G	Value Performance	105,000 Btu/hr. (30.8 kW)	43-lbs. (21 liters)	14 x 13-3/4 x 4-1/5 (35 x 34.9 x 10.7)	15-1/2 (39.4)	29-1/4 (74.3)	45 (114.3)	57-lbs. Fries/hr.	22 150-lbs. (68 kg)
SR52G	Value	120,000 Btu/hr. (35.2 kW)	50-lbs. (25 liters)	14 x 14 x 3-1/2 (35 x 35 x 8.9)	15-1/2 39.4	29-1/4 (74.3)	45 (114.3)	60-lbs. Fries/hr.	22 180-lbs. (82 kg)
SR62G	Value	150,000 Btu/hr. (44 kW)	75-lbs. (37 liters)	18 x 18 x 3-3/4 (46 x 46 x 9.5)	20 (50.8)	35-1/2 (90.2)	45 (114.3)	86-lbs. Fries/hr.	22 255-lbs. (116 kg)
D60G	Value Performance	150,000 Btu/hr. (44 kW)	75-lbs. (37 liters)	18 x 18 x 3-3/4 (46 x 46 x 9.5)	20 (50.8)	36-1/2 (92.7)	45 (114.3)	92-lbs. Fries/hr.	40 255-lbs. (116 kg)

¹ Weights and dimensions for these fryers are based on 2-battery units. All other measurements are per frypot.

MODEL NUMBER	FRYER CATEGORY	ENERGY REQ	OIL CAPACITY	COOKING AREA INCHES (CM) W × D × H	WIDTH INCHES (CM)	DEPTH INCHES (CM)	HEIGHT INCHES (CM)	PRODUCTION PER HR. (FULL FRYPOT)	APPROX. CUBIC FEET SHIP WT.
11814E	Oil Conserving	17 kW	60-lbs. (30 liters)	18 × 14 × 4-1/4 (45.7 × 35.6 × 10.8)	20 (50.8)	30-7/8 (78.4)	45-3/8 (114.9)	83-lbs. Fries/hr.	34 255-lbs. (116 kg)
FQE30	FilterQuick	14 kW	30-lbs. (15 liters)	13 × 14 × 3-3/4 (33 × 36 × 9.5)	31-1/4 (79.4)	30-7/8 (78.6)	45-3/8 (115.2)	14 kW 71-lbs. Fries/hr.	52 535-lbs. (243 kg)
FQE60	FilterQuick	17kW	60-lbs. (30 liters)	18 × 14 × 4-3/4 (45.7 × 35.6 × 12.1)	20 (50.8)	30-7/8 (78.4)	45-3/8 (114.9)	84-lbs. Fries/hr.	34 390-lbs. (177 kg)
FQE80 ¹	FilterQuick	17 kW	80-lb. (40 liter)	18 × 18 × 4-3/8 (46 × 46 × 11.1)	40 (101.6)	39-5/8 (100.5)	45-3/8 (114.9)	84 lbs. fries 80 lbs. bone-in chicken	52.3 640 lbs. (308 kg)
OCF30 (FPEL#30)	Oil Conserving	14 kW	30-lbs. (15 liters)	13 × 14 × 3-3/4 (33 × 36 × 9.5)	15-5/8 (39.7)	30-7/8 (78.6)	45-3/8 (115.2)	14 kW 71-lbs. Fries/hr.	21 255-lbs. (116 kg)
RE14TC/17TC	High Efficiency	14/17 kW	50-lbs. (25 liters)	14 × 15-1/2 × 3-3/4 (35.6 × 39.4 × 9.5)	15-5/8 (39.7)	31 (78.6)	45-3/8 (115.2)	70/74-lbs.(32/34 kg) Fries/hr.	21 214-lbs. (97 kg)
RE14-2TC/17-2TC	High Efficiency		25-lbs. (12 liters)	6-3/4 × 15-1/2 × 3-3/4 (17.1 × 39.4 × 9.5)					
RE14/17	High Efficiency	14/17 kW	50-lbs. (25 liters)	14 × 15-1/2 × 3-1/2 (35.6 × 39.4 × 8.9)	15-5/8 (39.7)	31 (78.6)	45-3/8 (115.2)	68/70-lbs. (30/31 kg) Fries/hr.	21 190-lbs. (86 kg)
RE14-2/17-2	High Efficiency		25-lbs. (12 liters)	6-3/4 × 15-1/2 × 3-1/2 (17.1 × 39.4 × 8.9)					
RE80	High Efficiency	17/21kW	80-lbs. (40 liters)	18 × 18 × 4-3/8 (45.7 × 45.7 × 12.1)	20 (50.8)	39-5/8 (100.7)	44-3/4 (113.7)	62-lbs. Fries/hr.	33 285-lbs. (129 kg)
SR14E	Value	14 kW	40-lbs. (20 liters)	13-3/4 × 13-3/4 × 5-1/4 (35 × 35 × 13.3)	15-3/4 (40)	27-1/4 (69)	44 (112)	56-lbs. Fries/hr.	21 180-lbs. (82 kg)

¹ Weights and dimensions for these fryers are based on 2-battery units. All other measurements are per frypot.

MODEL NUMBER	DESCRIPTION	ENERGY REQUIREMENTS	OIL CAPACITY	COOKING AREA INCHES (CM) W x D x H	WIDTH INCHES (CM)	DEPTH INCHES (CM)	HEIGHT INCHES (CM)	PRODUCTION PER HR. (FULL FRYPOT)	APPROX. CUBIC FEET SHIP WT.
PSDU50	Shortening Disposal Unit	N/A	50-lbs. (25 liters)	N/A	15-3/8 (39)	32 (81.3)	48 (121.9)	N/A	7 62-lbs. (28 kg)
PSDU100	Shortening Disposal Unit	N/A	100-lbs. (50 liters)	N/A	21 (53.3)	37-1 (95.3)	50 (127)	N/A	10 80-lbs. (36 kg)
PF80S/PF80R	Portable Filter	120V/60 Hz1 PH-6.2A	80-lbs. (40 liters)	18 x 18 x 5 (45.7 x 45.7 x 12.7)	20 (50.8)	39-5/8 (100.7)	44-3/4 (113.7)	84-lbs. Fries/hr.	32 285-lbs. (129 kg)
PF80LPS/PF80LPR	Portable Filter	120V/60 Hz1 PH-6.2A	80-lbs. (40 liters)	N/A	17.25" (43.8)	30.25" (76.8)	24.75" (62.9)	N/A	10.78 145-lbs. (54.4 kg)
PF110S/PF110R	Low Profile Portable Filter	120V/60 Hz1 PH-6.2A	110-lbs. (55 liters)	N/A	17.25" (43.8)	38.625" (98.1)	24.75" (62.9)	N/A	18.2 154-lbs. (67 kg)
PF50S/PF50R	Portable Filter	120V/60 Hz1 PH-6.2A	50-lbs. (25 liters)	N/A	17.25" (43.8)	30.25" (76.8)	24.75" (62.9)	N/A	10.78 146-lbs. (57 kg)
CDC63	Cleaning Disposal Caddy	N/A	63-lbs. (31 liters)	N/A	11-1/2" (29.1)	28-1/8" (71.4)	31-7/8" (80.8)	N/A	7.63 30-lbs. (14 kg)
CDC100	Cleaning Disposal Caddy	N/A	80-lbs. (40 liters)	N/A	16 (40.6)	10 (25.4)	32-1/2 (82.6)	N/A	7.63 120-lbs. (54.4 kg)

FRYMASTER & DEAN FACTORY WARRANTY

	FRYPOT	FRYPOT & ASSEMBLY	CONTROLLERS	ALL OTHER PARTS
ELECTRIC				
FilterQuick 30 Electric	1st Year: Parts And Labor 2nd Year - Lifetime: Part Only	N/A	1 Year: Parts & Labor 2nd Year: Parts Only	1 Year: Parts & Labor 2nd Year: Parts Only
FilterQuick 60 Electric	1st Year: Parts And Labor 2nd Year - Lifetime: Part Only	N/A	1 Year: Parts & Labor 2nd Year: Parts Only	1 Year: Parts & Labor 2nd Year: Parts Only
OCF30 Electric	1st Year: Parts And Labor 2nd Year - Lifetime: Part Only	N/A	1 Year: Parts & Labor 2nd Year: Parts Only	1 Year: Parts & Labor 2nd Year: Parts Only
1814E	1st Year: Parts And Labor 2nd Year - Lifetime: Part Only	N/A	1 Year: Parts & Labor	1 Year: Parts & Labor
RETC14/17	1st Year: Parts And Labor 2nd Year - Lifetime: Part Only	N/A	1 Year: Parts & Labor	1 Year: Parts & Labor
RE14/17	1st Year: Parts And Labor 2nd Year - Lifetime: Part Only	N/A	1 Year: Parts & Labor	1 Year: Parts & Labor
RE80	1st Year: Parts And Labor 2nd Year - Lifetime: Part Only	N/A	1 Year: Parts & Labor	1 Year: Parts & Labor

	COOK POT & ASSEMBLY	COOK POT	ALL OTHER PARTS
OTHER PRODUCTS			
Shortening Disposal Unit			90 Days: Parts & Labor 91 Days - 1 Year: Pump Part Only
CDC63			90 Days: Parts & Labor
Portable Filters			1 Year: Parts & Labor

WHAT THIS WARRANTY DOES NOT COVER

THE WARRANTIES PROVIDED BY FRYMASTER, LLC DO NOT APPLY IN THE FOLLOWING INSTANCES:

- Damage due to misuse, abuse, alteration, or accident.
- Improper or unauthorized repair.
- Failure to follow installation procedures, operation instructions and/or scheduled maintenance procedures as prescribed in your Frymaster or Dean Service and Owner's Manual.
- Damage in shipment.
- Removal, alteration, or obliteration of the rating plate.
- Changes in adjustment and calibrations after thirty (30) days from equipment installation date.
- Failure to program computer appliances in accordance with programming procedures prescribed in your Frymaster or Dean Service and Owner's Manual.
- Equipment exported to foreign countries.
- Normal maintenance items such as electric bulbs, fuses, gaskets, o-rings, interior and exterior finishes.
- Travel over 100 miles or two hours, overtime or holiday charges, all of which must be paid for by the purchaser.
- Consequential damages (the cost of repairing other property which is damaged), loss of time, profits, use or any other non-fryer related incidental damages of any kind.

GENERAL EXCLUSIONS

Warranty protection is only offered for fryers installed in accordance with the procedures described in the Frymaster or Dean Service and Owner's Manual.

There are no implied warranties of merchantability of fitness for any particular use or purpose. This warranty is the only and complete statement with respect to warranties of your commercial cooking appliances and computer/controller equipment manufactured by Frymaster. There are no other documents or oral statements for which Frymaster will be responsible.

LIMITED WARRANTY

Garland Canada (GC) warrants this product to be free from defects in material and workmanship for a period of one (1) year from the date the product is installed or twenty-four (24) months from the date of shipment from our facility, **whichever comes first**, and sold within Canada.

During the warranty period, GC shall, at GC's option, repair or replace parts determined by GC to be defective in material or workmanship, and with respect to services, shall re-perform any defective portion of said services. The foregoing shall be the sole obligation of GC under this Limited Warranty with respect to the equipment, products and services. With respect to equipment, materials, parts and Accessories manufactured by others, GC's sole obligation shall be to use reasonable efforts to obtain the full benefit of the manufacturer's warranties. GC shall have no liability, whether in contract, tort, negligence, or otherwise, with respect to non-GC manufactured products.

HOW LONG THE COVERAGE LASTS

MJH50/MJH55 High Efficiency models are warranted to be free of defects which would cause shortening leaks due to weld failures for five (5) years, parts and labour on frypot assembly. The combustion chamber, which consists of the infrared burners and the structural components to mount the burners, are also warranted against defective material or workmanship for seven (7) years, parts and labour.

Stainless steel frypots on all other fryers, except as noted below, are warranted to be free from defects which would cause shortening leaks due to weld failures for the period of one (1) year parts and labour.

Stainless frypots for models listed below are warranted for the length of time indicated, except that after one (1) year the warranty is limited to replacement parts. Warranty is deemed to be twelve (12) months from date of purchase or twenty-four (24) months from shipment from GC.

Five (5) years = GF14, GF40, MJ50, MJ40, Pasta Systems (gas and electric).

One (1) year = All cold rolled.

Fenwal thermostats are warranted for two (2) years except after one (1) year, the warranty is limited to replacement parts. All other part components are warranted for one (1) year from the date of purchase (parts and labour).

The shortening disposal unit is warranted for ninety (90) days parts only. In addition, the pump is warranted for one (1) year, parts only.

For MJH50/MJH55, MJ40/MJ50, after five (5) years, customer pays 50% of the list price of frypot plus all labour, travel, mileage, freight and importation,

WHO IS COVERED

This Limited Warranty is available only to the original purchaser of the product and is not transferable.

EXCLUSIONS FROM COVERAGE

- Repair or replacement of parts required because of misuse, improper care or storage, negligence, alteration, accident, use of incompatible supplies or lack of specified maintenance shall be excluded;
- Normal maintenance items, including but not limited to, light bulbs, fuses, gaskets, O-rings, interior and exterior finishes, lubrication, de-liming, broken glass, etc.;
- Failures caused by improper or erratic voltages;
- Improper or unauthorized repair;
- Changes in adjustment and calibration after thirty (30) days from equipment installation date;
- This Limited Warranty will not apply to any parts subject to damage beyond the control of GC, or to equipment which has been subject to alteration, misuse or improper installation, accidents, damage in shipment, fire, floods, power changes, other hazards or acts of God that are beyond the control of GC;
- This Limited Warranty does not apply, and shall not cover any products or equipment manufactured or sold by GC when such products or commercial equipment is installed or used in a residential or non-commercial application. Installations not within the applicable building

or fire codes render this Limited Warranty and any responsibility or obligations associated therein null and void. This includes any damage, costs or legal actions resulting from the installation of any GC commercial cooking equipment in a non-commercial application or installation, where the equipment is being used for applications other than those approved for by GC;

- If any product is cleaned without using an approved GC cleaning solution, this Limited Warranty shall be void;
- Removal, alterations or obliteration of the rating plate;
- Consequential damages (the cost of repairing other property which is damaged). Loss of time, profits or any other incidental damages of any kind;
- Failure to program Computer Magic® appliances in accordance with programming procedures prescribed in your Frymaster Service and Owner's Manual.

LIMITATIONS OF LIABILITY

The preceding paragraphs set forth the exclusive remedy for all claims based on failure of, or defect in, products or services sold hereunder, whether the failure or defect arises before or during the warranty period, and whether a claim, however instituted, is based on contract, indemnity, warranty, tort (including negligence), strict liability, implied by statute, common-law or otherwise, and GC its servants and agents shall not be liable for any claims for personal injuries, incidents or consequential damages or loss, howsoever caused. Upon the expiration of the warranty period, all such liability shall terminate. **THE FOREGOING WARRANTIES ARE EXCLUSIVE AND IN LIEU OF ALL OTHER WARRANTIES, WHETHER WRITTEN, ORAL, IMPLIED OR STATUTORY. NO IMPLIED WARRANTY OF MERCHANTABILITY OR FITNESS FOR PARTICULAR PURPOSE SHALL APPLY, GC DOES NOT WARRANT ANY PRODUCTS OR SERVICES OF OTHERS.**

REMEDIES

The liability of GC for breach of any warranty obligation hereunder is limited to: (i) the repair or replacement of the equipment on which the liability is based, or with respect to services, re-performance of the services; or (ii) at GC's option, the refund of the amount paid for said equipment or services. Any breach by GC with respect to any item or unit of equipment or services shall be deemed a breach with respect to that item or unit or service only.

WARRANTY CLAIM PROCEDURE

Customer shall be responsible to:

- Immediately advise the Dealer or GC's Factory Authorized Servicer of the equipment serial number and the nature of the problem. For a list of Factory Authorized Services, please refer to www.garlandcanadaservice.ca;
- Verify that the problem is a factory responsibility. Improper installation or misuse of equipment, is not covered under this Limited Warranty;
- Cooperate with the Factory Authorized Servicer so that warranty service may be completed during normal working hours;
- Travel time not to exceed two (2) hours and mileage not to exceed one hundred fifty (150) kilometres. Does not include travel other than overland, overtime, holiday charges and any special arrangement.

GOVERNING LAW

For equipment, products and services sold in Canada this Limited Warranty shall be governed by the laws of the province of Ontario, Canada excluding their conflicts of law principles. The United Nations Convention on Contracts for the International Sale of Goods is hereby excluded in its entirety from application to this Limited Warranty.

Garland Canada

1177 Kamato Road
Mississauga, Ontario
Canada L4W1X4

www.garlandcanada.ca

Tel: 905-624-1419 • 888-442-7526

Fax: 905-624-1851 • 800-361-2724

For more information, visit www.garlandcanada.ca

LIMITED WARRANTY

Garland Canada (GC) warrants this product to be free from defects in material and workmanship for a period of one (1) year from the date the product is installed or twenty-four (24) months from the date of shipment from our facility, **whichever comes first**, and sold within Canada.

During the warranty period, GC shall, at GC's option, repair or replace parts determined by GC to be defective in material or workmanship, and with respect to services, shall re-perform any defective portion of said services. The foregoing shall be the sole obligation of GC under this Limited Warranty with respect to the equipment, products and services. With respect to equipment, materials, parts and Accessories manufactured by others, GC's sole obligation shall be to use reasonable efforts to obtain the full benefit of the manufacturer's warranties. GC shall have no liability, whether in contract, tort, negligence, or otherwise, with respect to non-GC manufactured products.

HOW LONG THE COVERAGE LASTS

Frypots are warranted to be free from defects which would cause shortening leaks due to weld failures for the period of one (1) year, parts and labour. Models listed below are warranted for parts only for the length of time indicated.

Models SM35G, SR38, SR42, SR52, SR62, TC25, TC35

- One (1) year mild steel • Five (5) years prorated stainless steel *

Models SM20, SM50, SM60, SM80

- One (1) year mild steel • Five (5) years stainless steel

Models 1824 and 2424

- Four (4) years

Models 1414E, 1818E, 2020E, 18UE

- Four (4) years stainless steel

Models 1414G, 1818G, 2020G

- Five (5) years stainless steel

Models D35G, D50G, D60G, D80G

- Five (5) years mild steel • Ten (10) years stainless steel

*** PRO RATED FRYPOT WARRANTY**

- First year customer pays labour only
- Second year customer pays labour, freight and 20% of current frypot list price
- Third year customer pays labour, freight and 40% of current frypot list price
- Fourth year customer pays labour, freight and 60% of current frypot list price
- Fifth year customer pays labour, freight and 80% of current frypot list price
- After fifth year customer pays labour, freight and 100% of frypot and freight.

WHO IS COVERED

This Limited Warranty is available only to the original purchaser of the product and is not transferable.

EXCLUSIONS FROM COVERAGE

- Repair or replacement of parts required because of misuse, improper care or storage, negligence, alteration, accident, use of incompatible supplies or lack of specified maintenance shall be excluded;
- Normal maintenance items, including but not limited to, light bulbs, fuses, gaskets, O-rings, interior and exterior finishes, lubrication, de-liming, broken glass, etc.;
- Failures caused by improper or erratic voltages;
- Improper or unauthorized repair;
- Changes in adjustment and calibration after thirty (30) days from equipment installation date;
- This Limited Warranty will not apply to any parts subject to damage beyond the control of GC, or to equipment which has been subject to alteration, misuse or improper installation, accidents, damage in shipment, fire, floods, power changes, other hazards or acts of God that are beyond the control of GC;
- This Limited Warranty does not apply, and shall not cover any products or equipment manufactured or sold by GC when such products or

commercial equipment is installed or used in a residential or non-commercial application. Installations not within the applicable building or fire codes render this Limited Warranty and any responsibility or obligations associated therein null and void. This includes any damage, costs or legal actions resulting from the installation of any GC commercial cooking equipment in a non-commercial application or installation, where the equipment is being used for applications other than those approved for by GC;

- If any product is cleaned without using an approved GC cleaning solution, this Limited Warranty shall be void;
- Removal, alterations or obliteration of the rating plate;
- Consequential damages (the cost of repairing other property which is damaged). Loss of time, profits or any other incidental damages of any kind.

LIMITATIONS OF LIABILITY

The preceding paragraphs set forth the exclusive remedy for all claims based on failure of, or defect in, products or services sold hereunder, whether the failure or defect arises before or during the warranty period, and whether a claim, however instituted, is based on contract, indemnity, warranty, tort (including negligence), strict liability, implied by statute, common-law or otherwise, and GC its servants and agents shall not be liable for any claims for personal injuries, incidents or consequential damages or loss, howsoever caused. Upon the expiration of the warranty period, all such liability shall terminate. **THE FOREGOING WARRANTIES ARE EXCLUSIVE AND IN LIEU OF ALL OTHER WARRANTIES, WHETHER WRITTEN, ORAL, IMPLIED OR STATUTORY. NO IMPLIED WARRANTY OF MERCHANTABILITY OR FITNESS FOR PARTICULAR PURPOSE SHALL APPLY, GC DOES NOT WARRANT ANY PRODUCTS OR SERVICES OF OTHERS.**

REMEDIES

The liability of GC for breach of any warranty obligation hereunder is limited to: (i) the repair or replacement of the equipment on which the liability is based, or with respect to services, re-performance of the services; or (ii) at GC's option, the refund of the amount paid for said equipment or services. Any breach by GC with respect to any item or unit of equipment or services shall be deemed a breach with respect to that item or unit or service only.

WARRANTY CLAIM PROCEDURE

Customer shall be responsible to:

- Immediately advise the Dealer or GC's Factory Authorized Servicer of the equipment serial number and the nature of the problem. For a list of Factory Authorized Services, please refer to www.garlandcanadaservice.ca;
- Verify that the problem is a factory responsibility. Improper installation or misuse of equipment, is not covered under this Limited Warranty;
- Cooperate with the Factory Authorized Servicer so that warranty service may be completed during normal working hours;
- Travel time not to exceed two (2) hours and mileage not to exceed one hundred fifty (150) kilometres. Does not include travel other than overland, overtime, holiday charges and any special arrangement.

GOVERNING LAW

For equipment, products and services sold in Canada this Limited Warranty shall be governed by the laws of the province of Ontario, Canada excluding their conflicts of law principles. The United Nations Convention on Contracts for the International Sale of Goods is hereby excluded in its entirety from application to this Limited Warranty.

Garland Canada

1177 Kamato Road
Mississauga, Ontario
Canada L4W1X4

www.garlandcanada.ca

Tel: 905-624-1419 • 888-442-7526

Fax: 905-624-1851 • 800-361-2724

For more information, visit www.garlandcanada.ca

Canadian Regional Sales Representatives



REGION	REP / AGENT	E-MAIL	CELLULAR
British Columbia	Ryan Lewis – Sales Rep	ryan@masales.ca	604-329-0684
	Mark Thiessen – Sales Rep	mark@masales.ca	604-657-7615
Alberta	James Goodman – Sales Rep (Calgary)	james@masales.ca	403-618-3636
	Collin Von Hansen – Sales Rep	collin@masales.ca	587-832-2090
	Sandro Salvador – Sales Rep (Edmonton)	sandro@masales.ca	780-405-2637
Prairies	Jeff McGowan – Sales Rep (SK, MB)	mcgowansales@bellnet.ca	647-231-3815
Ontario	Chris Ozog – Sales Rep (Central ON)	chris.ozog@garland-group.com	416-526-7989
	Geoff Scott – Regional Sales Manager Rep (Southern & Western ON)	geoff.scott@garland-group.com	647-828-9391
	Chris Taylor – Sales Rep (Central ON)	chris.taylor@garland-group.com	416-358-4421
	Jeff McGowan – Sales Rep (Northeastern ON)	mcgowansales@bellnet.ca	647-231-3815
Quebec	Maxime Gaudreault – Regional Sales Manager Rep (Quebec City)	maxime.gaudreault@garland-group.com	437-577-3719
	Michel Grenier – Sales Rep (Montreal)	michel.grenier@garland-group.com	437-333-3447
Atlantic Canada	Aaron Taylor – Sales Rep (PEI, NB)	aaron@tayloragencies.com	506-872-1177
	Steven Donnelly – Sales Rep (NS, NL)	steven@tayloragencies.com	902-999-7631

GARLAND CANADA CUSTOMER SERVICE	VOICE	FAX
Sales	(888) 442-7526	(800) 361-2724
KitchenCare (Parts, Service and Warranty)	(844) 724-2273	N/A

Scan the code below to locate a dealer, distributor or sales representative in your area.



www.garlandcanada.ca/sales/buy-locally



Welbilt offers fully-integrated kitchen systems with award-winning product brands: **Cleveland™**, **Convotherm®**, **Delfield®**, **Frymaster®**, **Garland®**, **Kolpak®**, **Lincoln®**, **Merco®**, **Merrychef®** and **Multiplex®**. Supported by service brands: **KitchenCare®**, aftermarket parts and service; **FitKitchen®**, fully-integrated kitchen systems; and **KitchenConnect®**, cloud-based open digital platform.

Bringing innovation to the table • welbilt.com